

RCD-W500C

SERVICE MANUAL

Ver 1.2 2004.08



US Model
Canadian Model



CD Section	Model Name Using Similar Mechanism	NEW
	CD Mechanism Type	CDM53L-30B61M
	Base Unit Type	BU-30BBD61M
	Optical Pick-up Type	A-MAX.4T
CD-R/CD-RW Section	Model Name Using Similar Mechanism	RCD-W100
	CD Mechanism Type	CDM65-RBD2
	Base Unit Type	RBD2
	Optical Pick-up Type	KRM-220CAA

SPECIFICATIONS

DECK A (the CD player section)

System	Compact disc digital audio system
Laser	Semiconductor laser ($\lambda = 780$ nm) Emission duration: continuous
Playable discs	CD, CD-R, CD-RW
Frequency response	20 Hz - 20,000 Hz (± 0.5 dB)
Signal to Noise Ratio	Over 98 dB during play
Wow and flutter	Below measurable limit

DECK B (the CD-R and CD-RW recording section)

System	Compact disc digital audio system
Laser	Semiconductor laser ($\lambda = 780$ nm) Emission duration: continuous
Playable discs	CD, CD-R, CD-RW
Recordable discs	CD-R, CD-RW (for Audio)
Frequency response	20 Hz - 20,000 Hz (± 0.5 dB)
Signal to Noise Ratio	Over 98 dB during play
Wow and flutter	Below measurable limit

Inputs

ANALOG IN (Phono jacks)	Impedance: 47 kilohms Rated input: 500 mVrms Minimum input: 250 mVrms
DIGITAL OPTICAL IN (Square optical connector jack)	Optical wavelength: 660 nm

Outputs

ANALOG OUT (Phono jacks)	Rated output: 2 Vrms Load impedance: over 10 kilohms
DIGITAL OPTICAL OUT (Square optical connector jack)	Wavelength: 660 nm Rated output: -18 dBm
PHONES (Stereo phone jack)	Load impedance: 32 ohms Rated output: 12mW

General

Power requirements	120 V AC, 60 Hz
Power consumption	25 W
Dimensions (approx.) (w/h/d) incl. projecting parts and control	430 × 108 × 399 mm (17 × 4 3/8 × 15 3/4 inch)
Mass (approx.)	6.8 kg (15 lbs)
Supplied accessories	<ul style="list-style-type: none">• Audio connecting cords• Phono plug × 2 (red/white) ↔ Phono plug × 2 (red/white) (2)• Remote commander (remote) (1)• R6 (size AA) batteries (2)

Design and specifications are subject to change without notice.

COMPACT DISC RECORDER

9-877-447-03
2004H16-1
© 2004.08

Sony Corporation
Audio Group
Published by Sony Engineering Corporation

SONY®

Laser component in this product is capable of emitting radiation exceeding the limit for Class 1.

CAUTION

Use of controls or adjustments or performance of procedures other than those specified herein may result in hazardous radiation exposure.

Notes on chip component replacement

- Never reuse a disconnected chip component.
- Notice that the minus side of a tantalum capacitor may be damaged by heat.

Flexible Circuit Board Repairing

- Keep the temperature of soldering iron around 270°C during repairing.
- Do not touch the soldering iron on the same conductor of the circuit board (within 3 times).
- Be careful not to apply force on the conductor when soldering or unsoldering.

SAFETY CHECK-OUT

After correcting the original service problem, perform the following safety checks before releasing the set to the customer: Check the antenna terminals, metal trim, “metallized” knobs, screws, and all other exposed metal parts for AC leakage. Check leakage as described below.

LEAKAGE

The AC leakage from any exposed metal part to earth ground and from all exposed metal parts to any exposed metal part having a return to chassis, must not exceed 0.5 mA (500 microamperes). Leakage current can be measured by any one of three methods.

1. A commercial leakage tester, such as the Simpson 229 or RCA WT-540A. Follow the manufacturers’ instructions to use these instruments.
2. A battery-operated AC milliammeter. The Data Precision 245 digital multimeter is suitable for this job.
3. Measuring the voltage drop across a resistor by means of a VOM or battery-operated AC voltmeter. The “limit” indication is 0.75 V, so analog meters must have an accurate low-voltage scale. The Simpson 250 and Sanwa SH-63Trd are examples of a passive VOM that is suitable. Nearly all battery operated digital multimeters that have a 2V AC range are suitable. (See Fig. A)

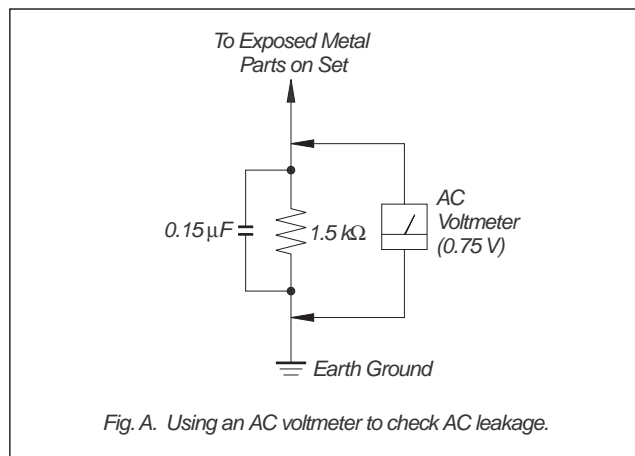

MODEL IDENTIFICATION

— BACK PANEL —

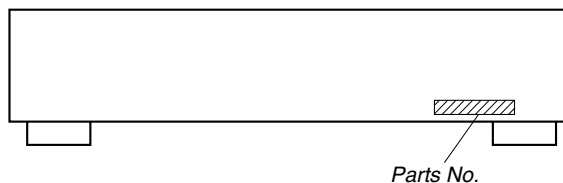

SAFETY-RELATED COMPONENT WARNING!!

COMPONENTS IDENTIFIED BY MARK \triangle OR DOTTED LINE WITH MARK \triangle ON THE SCHEMATIC DIAGRAMS AND IN THE PARTS LIST ARE CRITICAL TO SAFE OPERATION. REPLACE THESE COMPONENTS WITH SONY PARTS WHOSE PART NUMBERS APPEAR AS SHOWN IN THIS MANUAL OR IN SUPPLEMENTS PUBLISHED BY SONY.

ATTENTION AU COMPOSANT AYANT RAPPORT À LA SÉCURITÉ!

LES COMPOSANTS IDENTIFÉS PAR UNE MARQUE \triangle SUR LES DIAGRAMMES SCHÉMATIQUES ET LA LISTE DES PIÈCES SONT CRITIQUES POUR LA SÉCURITÉ DE FONCTIONNEMENT. NE REMPLACER CES COMPOSANTS QUE PAR DES PIÈCES SONY DONT LES NUMÉROS SONT DONNÉS DANS CE MANUEL OU DANS LES SUPPLÉMENTS PUBLIÉS PAR SONY.

PARTS No.	MODEL
4-246-074-0□	US
4-246-074-1□	Canadian

TABLE OF CONTENTS

Unleaded solder

Boards requiring use of unleaded solder are printed with the lead-free mark (LF) indicating the solder contains no lead.

(Caution: Some printed circuit boards may not come printed with the lead free mark due to their particular size.)

**: LEAD FREE MARK**

Unleaded solder has the following characteristics.

- Unleaded solder melts at a temperature about 40°C higher than ordinary solder.

Ordinary soldering irons can be used but the iron tip has to be applied to the solder joint for a slightly longer time.

Soldering irons using a temperature regulator should be set to about 350°C.

Caution: The printed pattern (copper foil) may peel away if the heated tip is applied for too long, so be careful!

- Strong viscosity

Unleaded solder is more viscous (sticky, less prone to flow) than ordinary solder so use caution not to let solder bridges occur such as on IC pins, etc.

- Usable with ordinary solder

It is best to use only unleaded solder but unleaded solder may also be added to ordinary solder.

1. SERVICING NOTE	4
2. GENERAL	5
3. DISASSEMBLY	6
3-1. Case (409538)	7
3-2. Loading Panel (CDR)	7
3-3. Front Panel Section	8
3-4. SW Board, LED Board, DISP Board	8
3-5. CD Mechanism Deck (CDM65-RBD2)	9
3-6. Tray	9
3-7. CDR Board	10
3-8. Motor Assy (Loading) (M201)	10
3-9. Holder (MG) Sub Assy, Dust Cover	11
3-10. Optical Pick-Up (KRM-220CAA)	11
3-11. Cam (CH)	12
3-12. MAIN Board	12
3-13. CD Mechanism Deck (CDM53L-30B61M)	13
3-14. Fitting Base (Magnet) Assy	13
3-15. CLAMP MOTOR Board, Motor (Clamp) Assy (M701)	14
3-16. Fitting Base (Guide) Assy, Bracket (Chassis)	14
3-17. Tray (Sub)	15
3-18. Chassis (Mold B)	15
3-19. LOAD MOTOR Board, Motor (Loading) Assy (M702)	16
3-20. Stocker Section	16
3-21. Slider (Selection), Tension Spring (Shutter), Slider (Shutter)	17
3-22. Gear (Gear A), Gear (Gear B), Gear (U/D Slider) Precaution During Gear (Gear U/D Slider), Gear (Gear B), Gear (Gear A) Installation	17
3-23. Gear (Chucking)	18
3-24. BD Board	19
3-25. Optical Block Section	19
4. TEST MODE	20
5. ELECTRICAL ADJUSTMENTS	
CD SECTION	23
CD-R/RW SECTION	25
6. DIAGRAMS	55
6-1. Block Diagrams – CD-R Section –	56
– CD Section –	57
– POWER/DISPLAY Section –	58
6-2. Printed Wiring Boards – BD Section –	59
6-3. Schematic Diagrams – BD Section –	60
6-4. Printed Wiring Boards – SENSER/MOTOR/SW Section –	61
6-5. Schematic Diagrams – SENSER/MOTOR/SW Section –	62
6-6. Printed Wiring Boards – CD-R Section (Side A) –	63
6-7. Printed Wiring Boards – CD-R Section (Side B) –	64
6-8. Schematic Diagrams – CD-R Section (1/4) –	65
6-9. Schematic Diagrams – CD-R Section (2/4) –	66
6-10. Schematic Diagrams – CD-R Section (3/4) –	67
6-11. Schematic Diagrams – CD-R Section (4/4) –	68
6-12. Printed Wiring Boards – MAIN Section (Side A) –	69
6-13. Printed Wiring Boards – MAIN Section (Side B) –	70
6-14. Schematic Diagrams – MAIN Section (1/2) –	71
6-15. Schematic Diagrams – MAIN Section (2/2) –	72
6-16. Printed Wiring Boards – LED Section –	73
6-17. Schematic Diagrams – LED Section –	74
6-18. Printed Wiring Boards – DISPLAY Section –	75
6-19. Schematic Diagrams – DISPLAY Section –	76
6-20. IC Block Diagrams	77
6-21. IC Pin Function Description	84
7. EXPLODED VIEWS	
7-1. Case Section	94
7-2. Front Panel Section	95
7-3. Chassis Section	96
7-4. Overall Section (CDM53L-30B61M)	97
7-5. Chassis (Mold) Assy Section (CDM53L-30B61M)	98
7-6. Chassis Section (CDM53L-30B61M)	99
7-7. Base Unit Section (BU-30BBD61M)	100
7-8. CDM65-RBD2	101
8. ELECTRICAL PARTS LIST	102

Self-diagnosis Function

When the self-diagnosis function is activated to prevent the player from malfunctioning, three character service numbers in a combination with a message appears in the display. In this case, check the following table.

Message	Explanation
C12/ Cannot Copy	<p>You are trying to record a disc that cannot be played back in DECK-A or with an external device, such as CD-ROM or VIDEO CD.</p> <ul style="list-style-type: none"> Remove the disc, and then insert a music CD for playback.
C13/ Rec Error	<p>Recording has not been completed successfully because of vibration.</p> <ul style="list-style-type: none"> Relocate the unit in a place free of vibration and restart the recording again. <p>The disc you try to record is excessively dirty (such as oil-stained or finger marked) or scratched. Or the disc is not normal.</p> <ul style="list-style-type: none"> Replace the disc with another one and restart the recording again.
C14/ TOC Error	<p>The unit did not read the TOC information.</p> <ul style="list-style-type: none"> Insert other discs.
C41/ Cannot Copy	<p>The sound source you are trying to record is a copy of a commercial music software. Or you are trying to record on a CD-R/CD-RW digitally.</p> <ul style="list-style-type: none"> Because of the restriction of the Serial Copy Management System, you cannot record a copy of a commercial music software. Neither can you record a CD-R/CD-RW digitally.
C71/ Din Unlock	<p>If this message is displayed momentarily, this is not an error. It is caused by the digital signal during recording.</p> <p>During recording of a digital sound source, the connecting cable has been disconnected or the player of the sound source has turned off.</p> <ul style="list-style-type: none"> Connect the cable or turn on the digital player.

NOTES ON HANDLING THE OPTICAL PICK-UP BLOCK OR BASE UNIT

The laser diode in the optical pick-up block may suffer electrostatic break-down because of the potential difference generated by the charged electrostatic load, etc. on clothing and the human body. During repair, pay attention to electrostatic break-down and also use the procedure in the printed matter which is included in the repair parts.

The flexible board is easily damaged and should be handled with care.

NOTES ON LASER DIODE EMISSION CHECK

The laser beam on this model is concentrated so as to be focused on the disc reflective surface by the objective lens in the optical pick-up block. Therefore, when checking the laser diode emission, observe from more than 30 cm away from the objective lens. The emission check enables continuous checking of the S curve.

LASER DIODE AND FOCUS SEARCH OPERATION CHECK

Carry out the "S curve check" in "CD section adjustment" and check that the S curve waveform is output three times.

SECTION 2 GENERAL

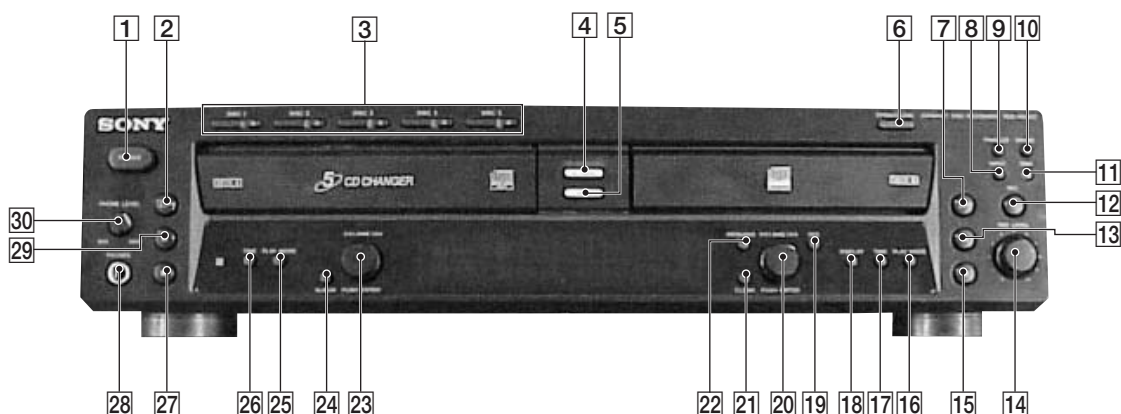

- | | |
|---|------------------------------|
| 1 POWER button | 16 PLAY MODE button |
| 2 ▷ button | 17 TIME button |
| 3 DISC 1 to DISC 5 ≡ button and indicators | 18 DISPLAY button |
| 4 CD SYNCHRO NORMAL button | 19 YES button |
| 5 CD SYNCHRO HIGH button | 20 ◀◀ AMS ▶▶ knob |
| 6 OPEN/CLOSE button | 21 CLEAR button |
| 7 ▷ button | 22 MENU/NO button |
| 8 INPUT button | 23 ◀◀ AMS ▶▶ knob |
| 9 FINALIZE button | 24 ALBUM button |
| 10 ERASE button | 25 PLAY MODE button |
| 11 SBM button and indicator | 26 TIME button |
| 12 REC ● button | 27 ■ button |
| 13 button | 28 PHONES jack |
| 14 REC LEVEL knob | 29 button |
| 15 ■ button | 30 PHONE LEVEL knob |

SECTION 3 DISASSEMBLY

- Note :**
- Disassemble the unit in the order as shown below.
 - This set can be disassembled according to the following sequence.
The dotted square with arrow (□→) prompts you to move to the next job when all of the works within the dotted square (□) are completed.

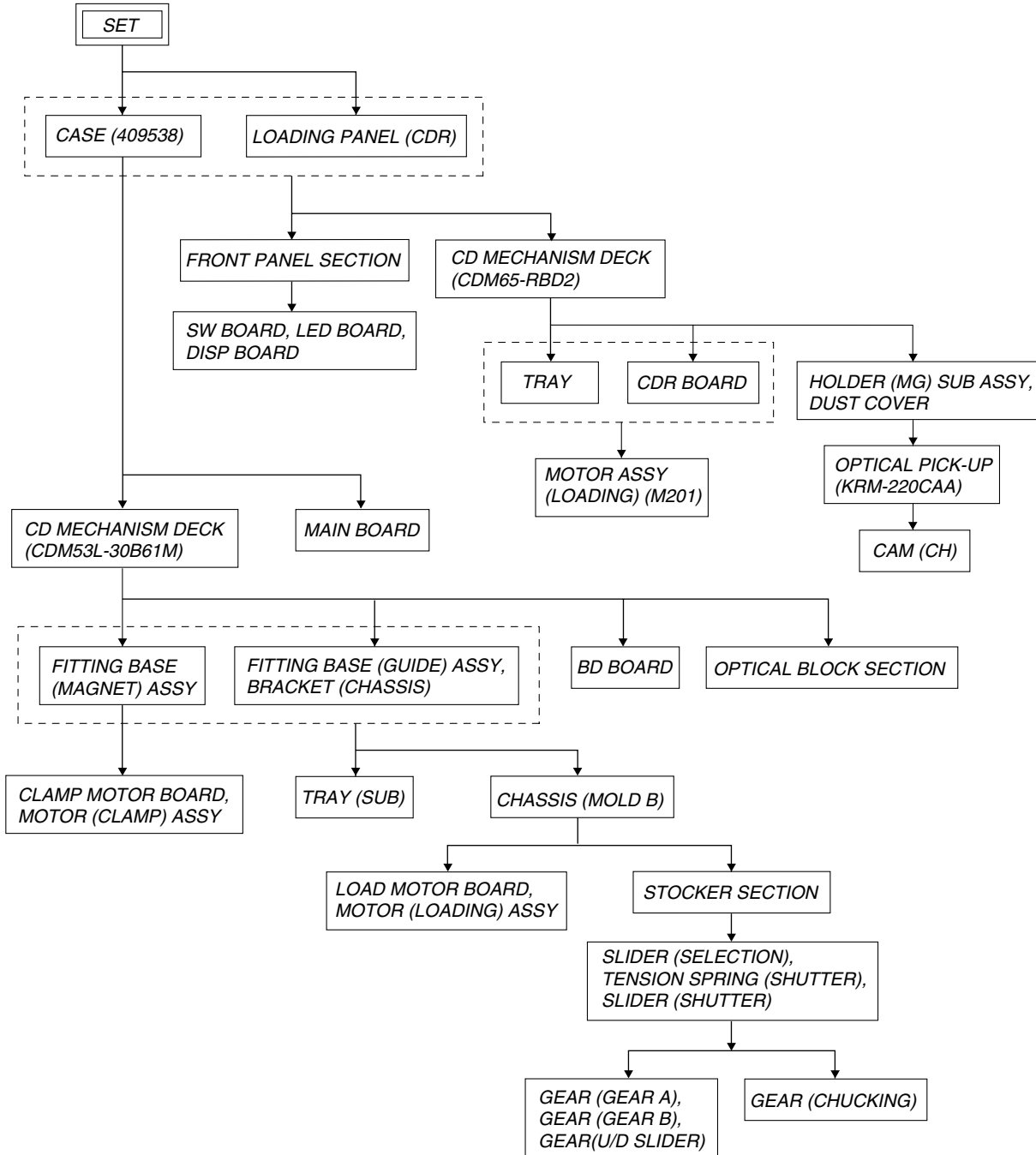

Note : Follow the disassembly procedure in the numerical order given.

3-1. Case (409538)

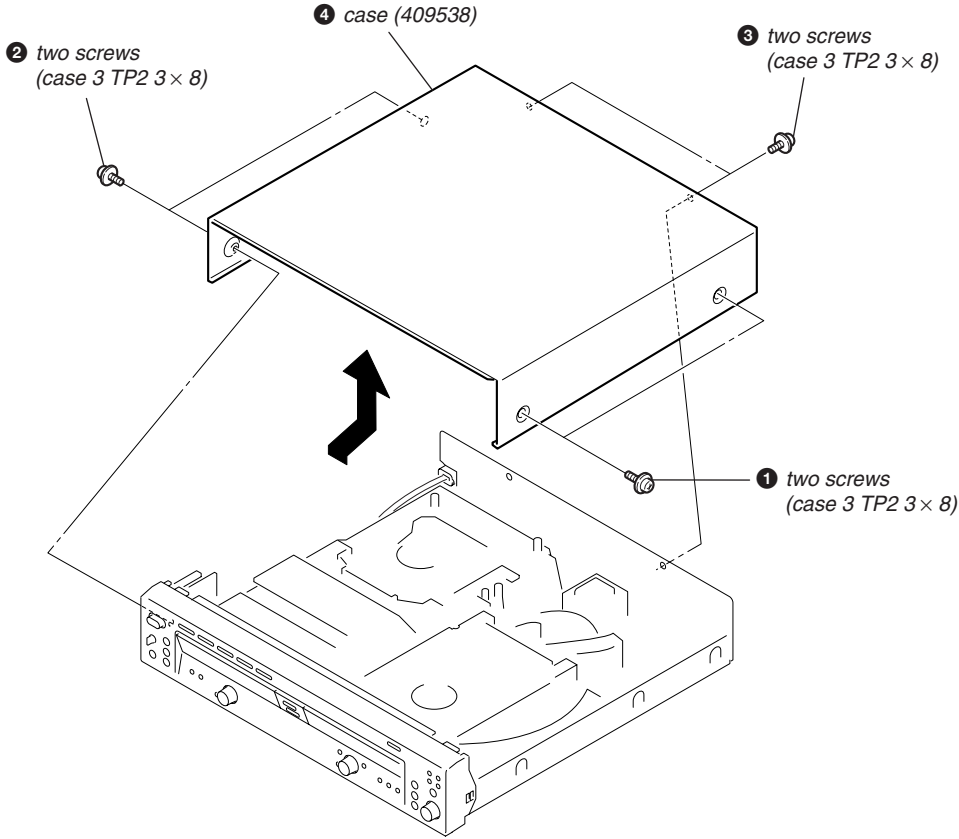

3-2. Loading Panel (CDR)

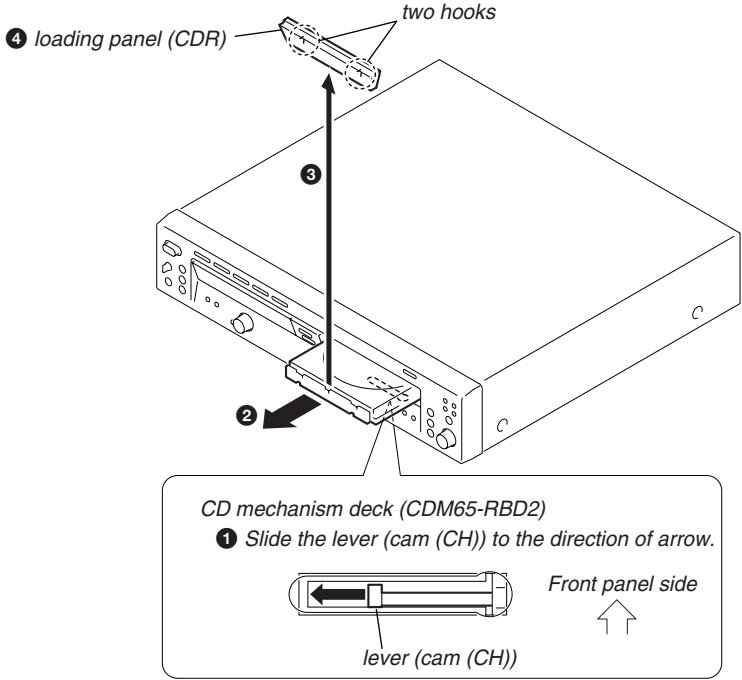

3-3. Front Panel Section

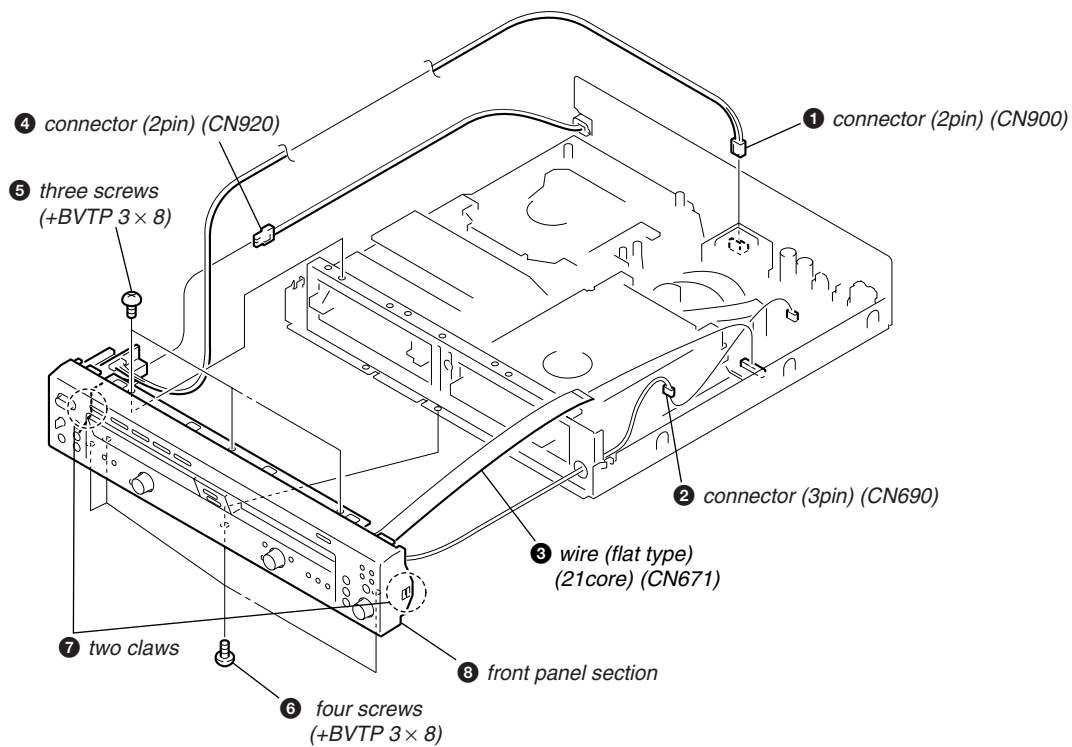

3-4. SW Board, LED Board, DISP Board

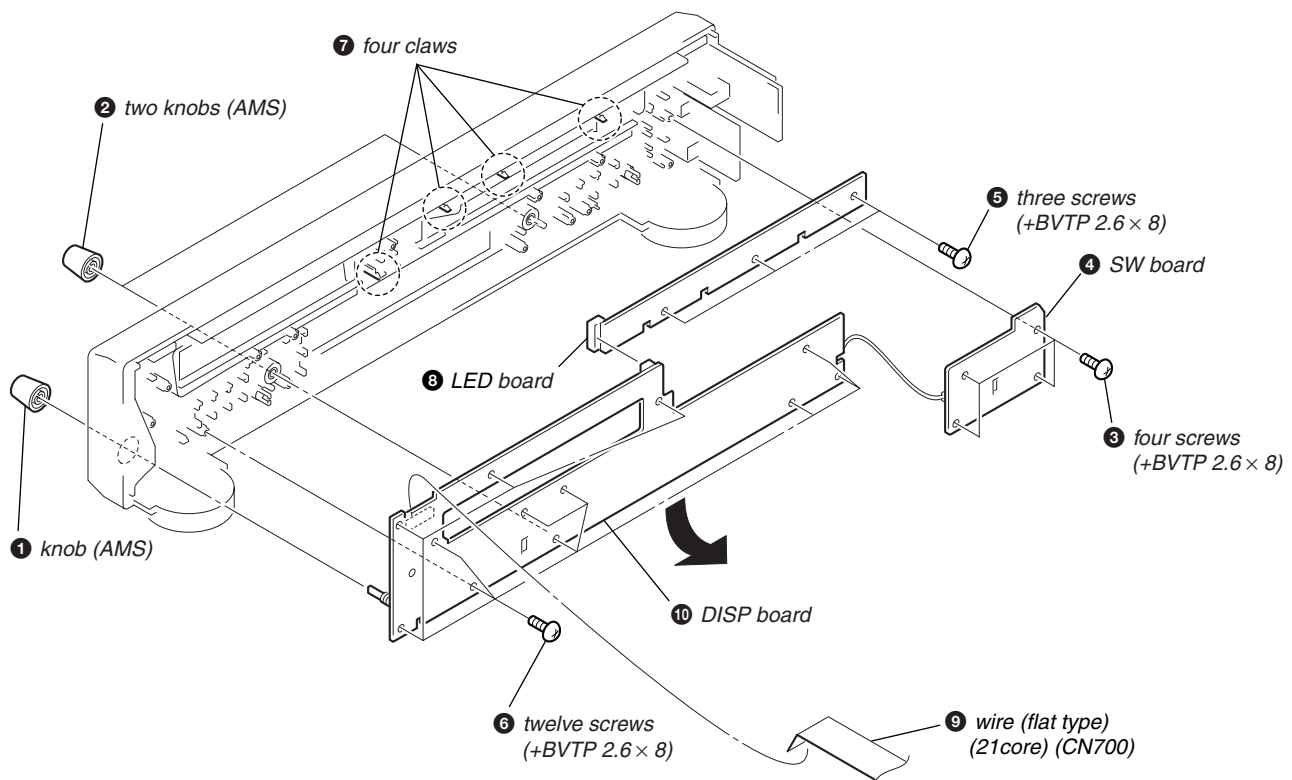

3-5. CD Mechanism Deck (CDM65-RBD2)

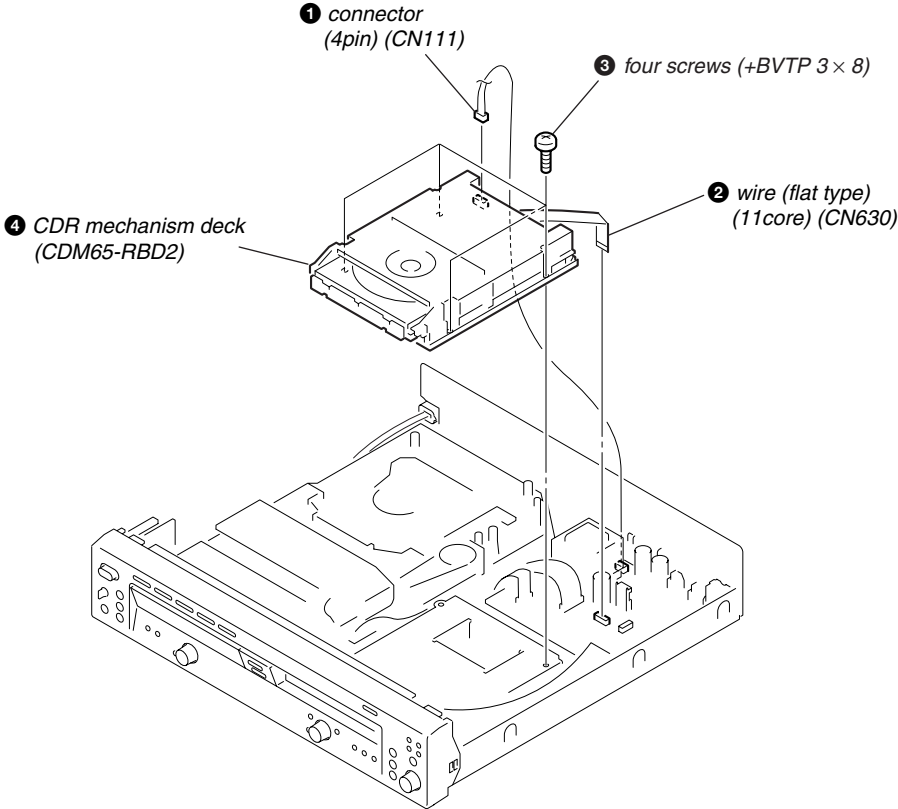

3-6. Tray

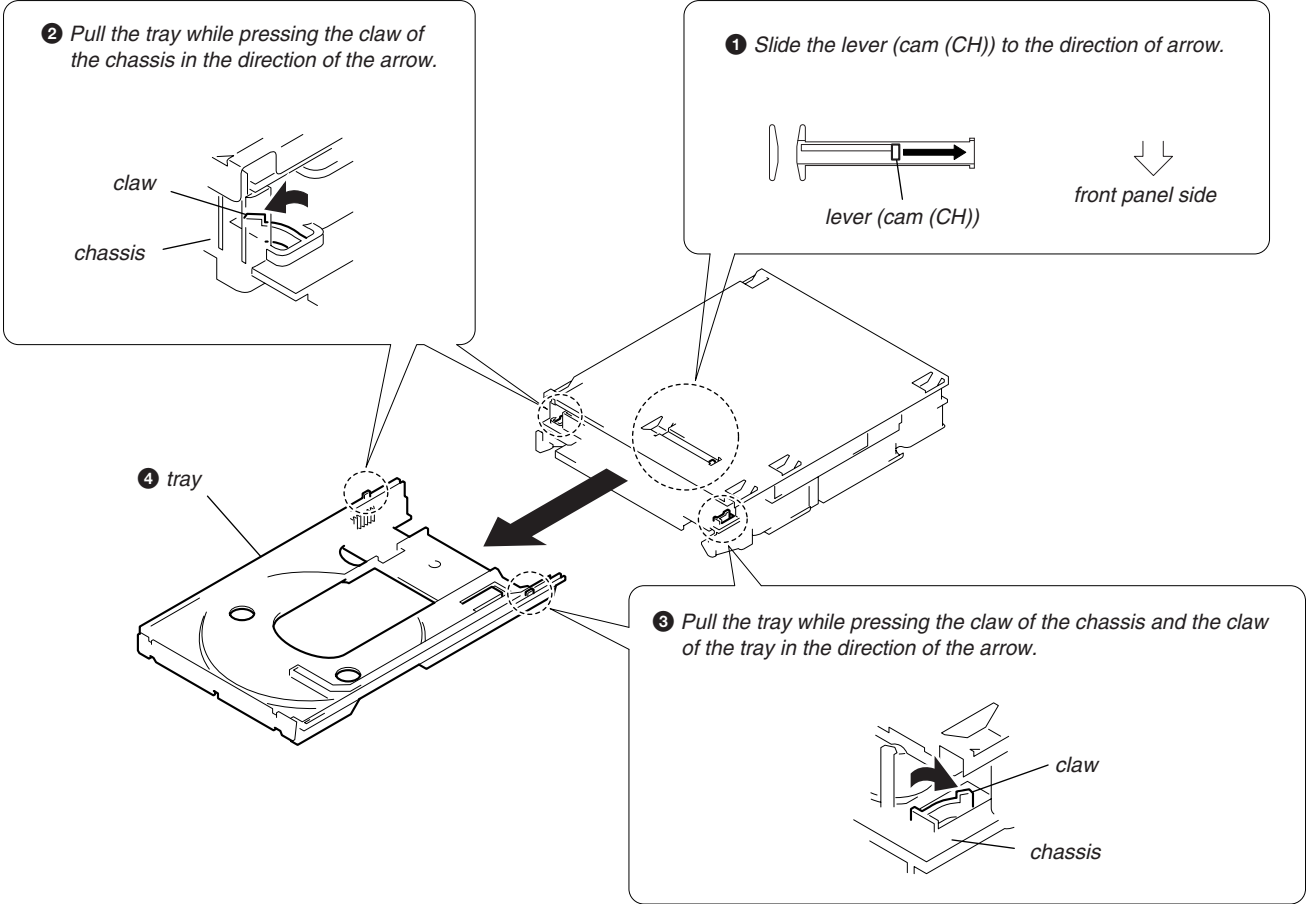

3-7. CDR Board

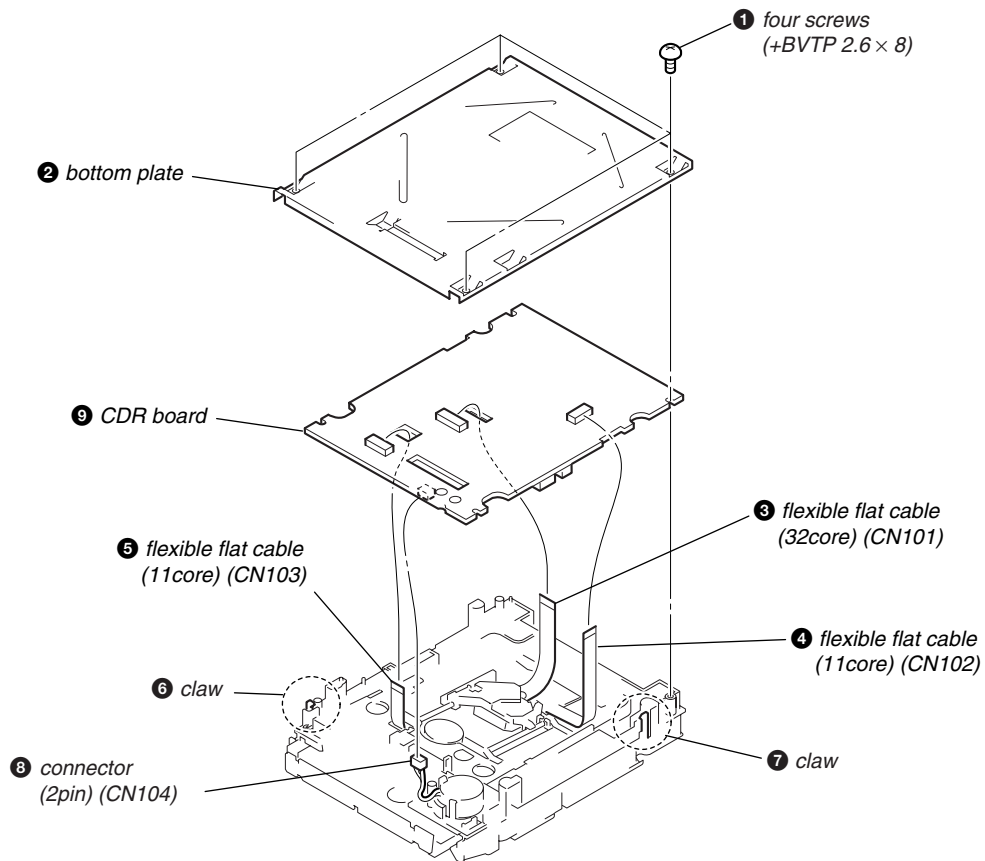

3-8. Motor Assy (Loading) (M201)

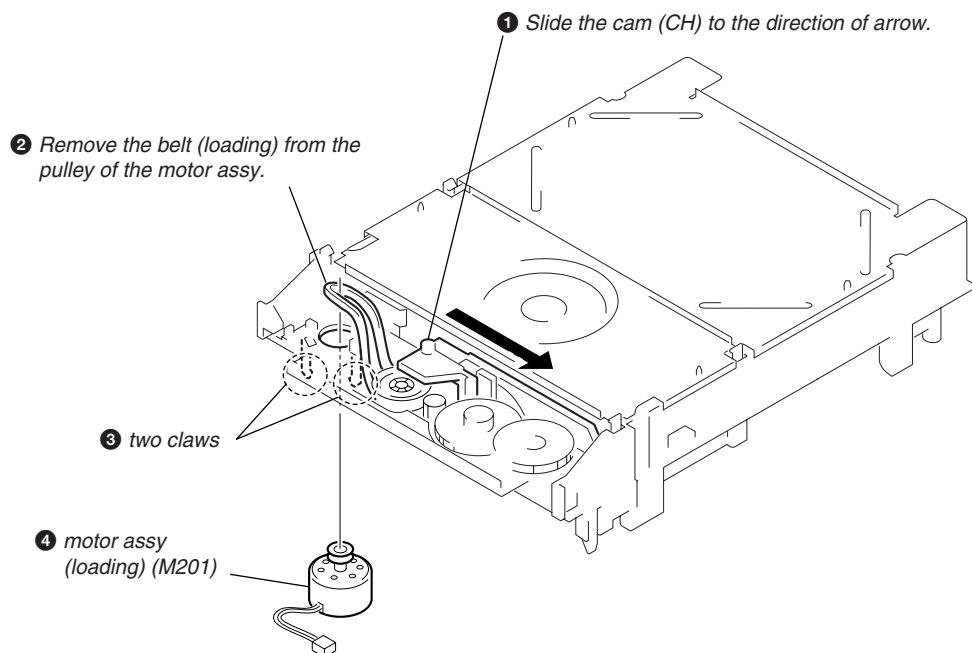

3-9. Holder (MG) Sub Assy, Dust Cover

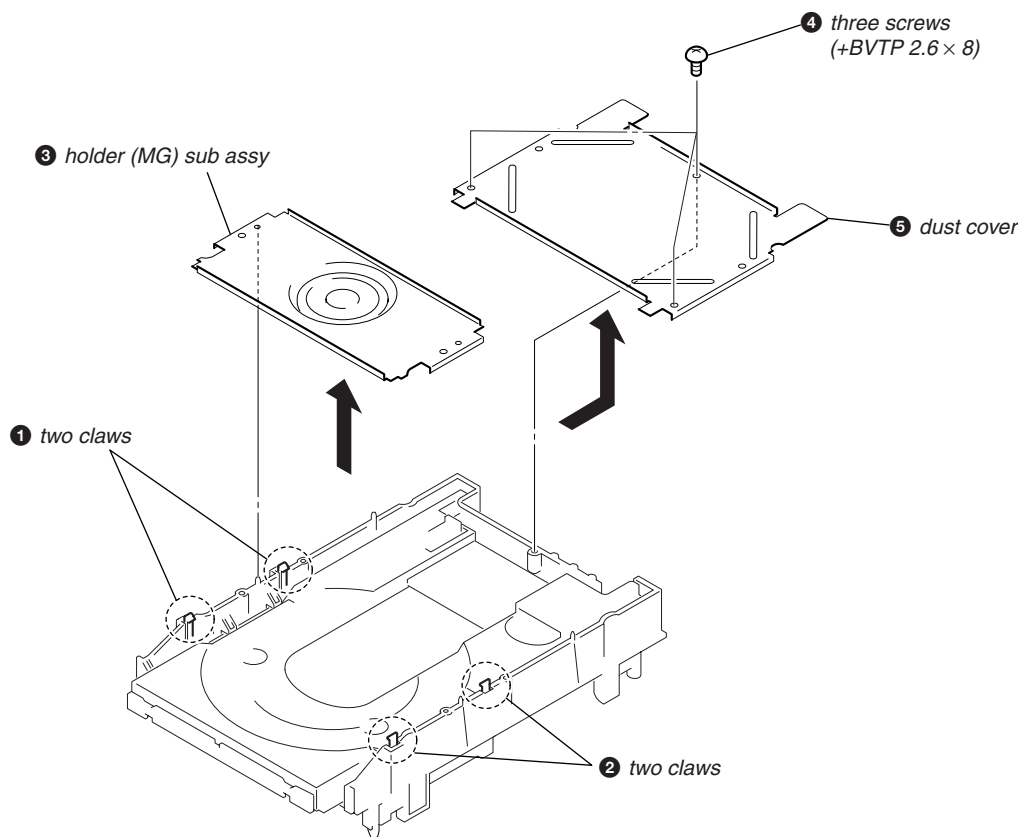

3-10. Optical Pick-Up (KRM-220CAA)

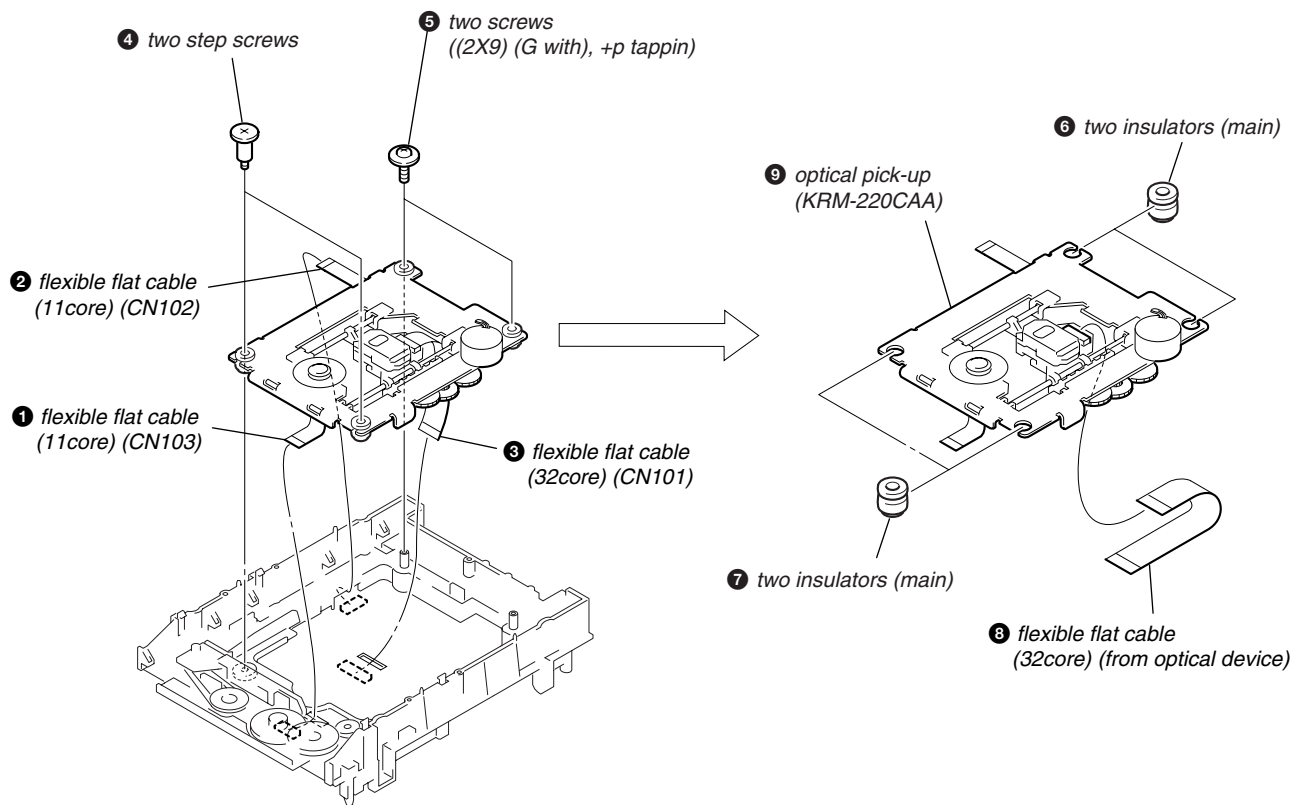

3-11. Cam (CH)

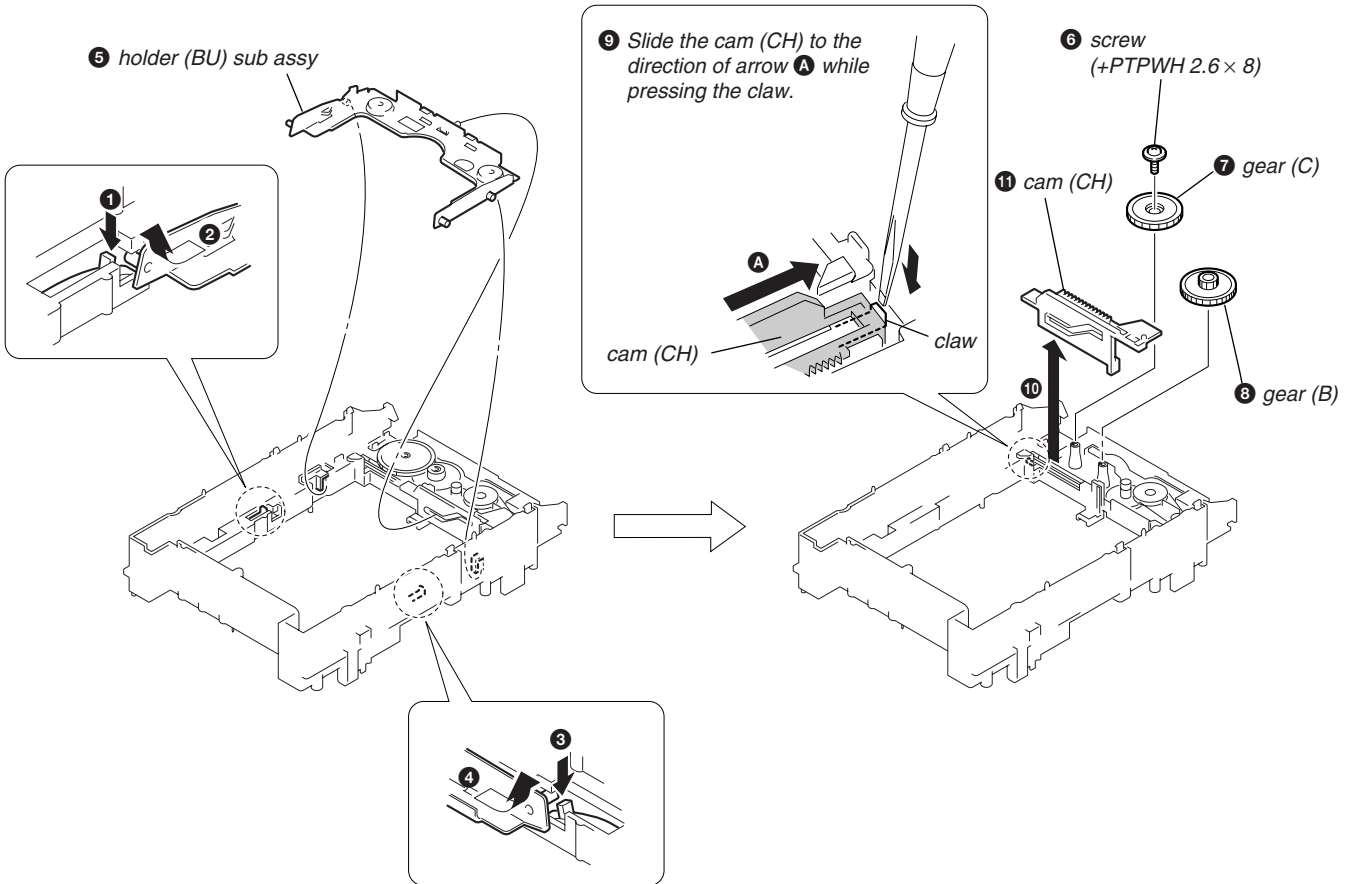

3-12. MAIN Board

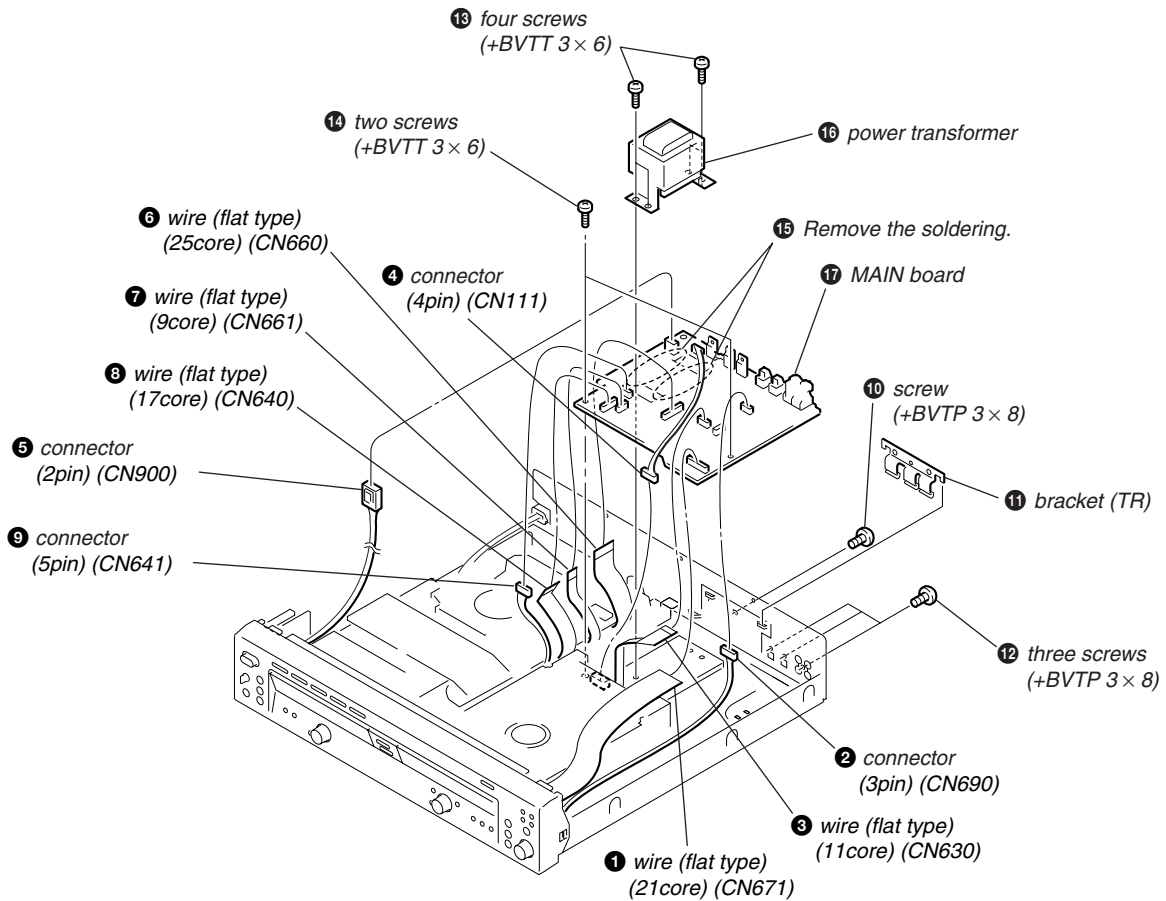

3-13. CD Mechanism Deck (CDM53L-30B61M)

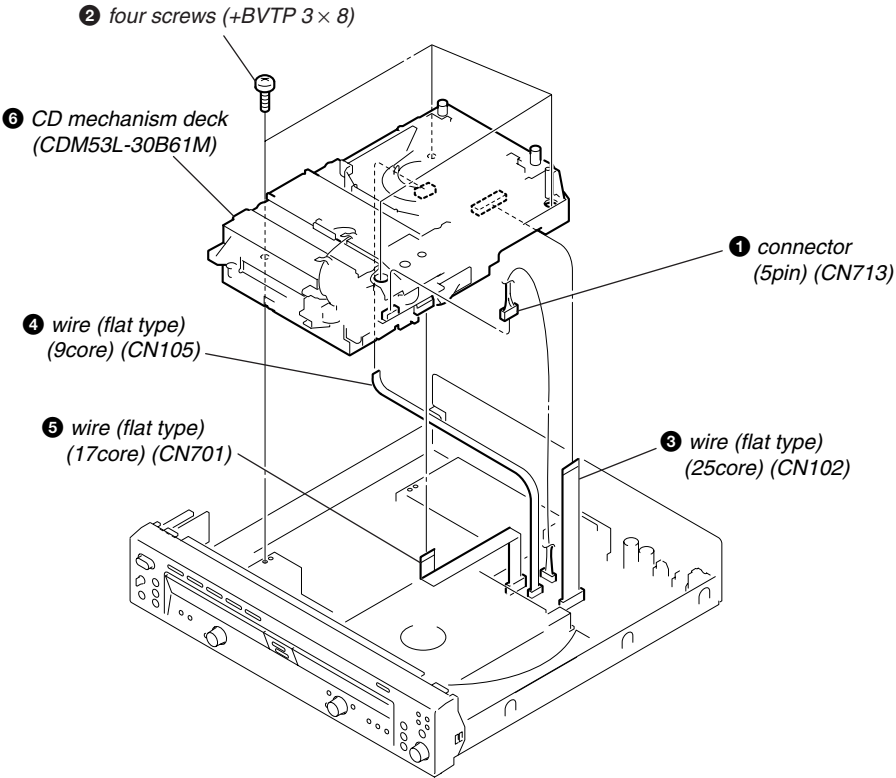

3-14. Fitting Base (Magnet) Assy

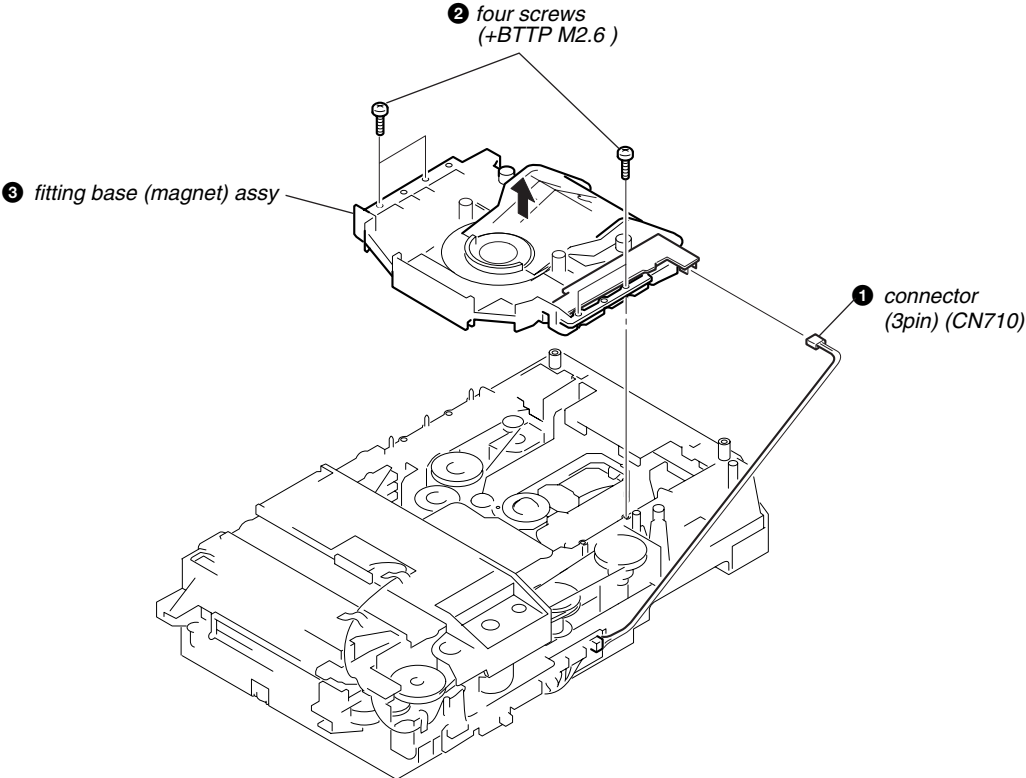

3-15. CLAMP MOTOR Board, Motor (Clamp) Assy (M701)

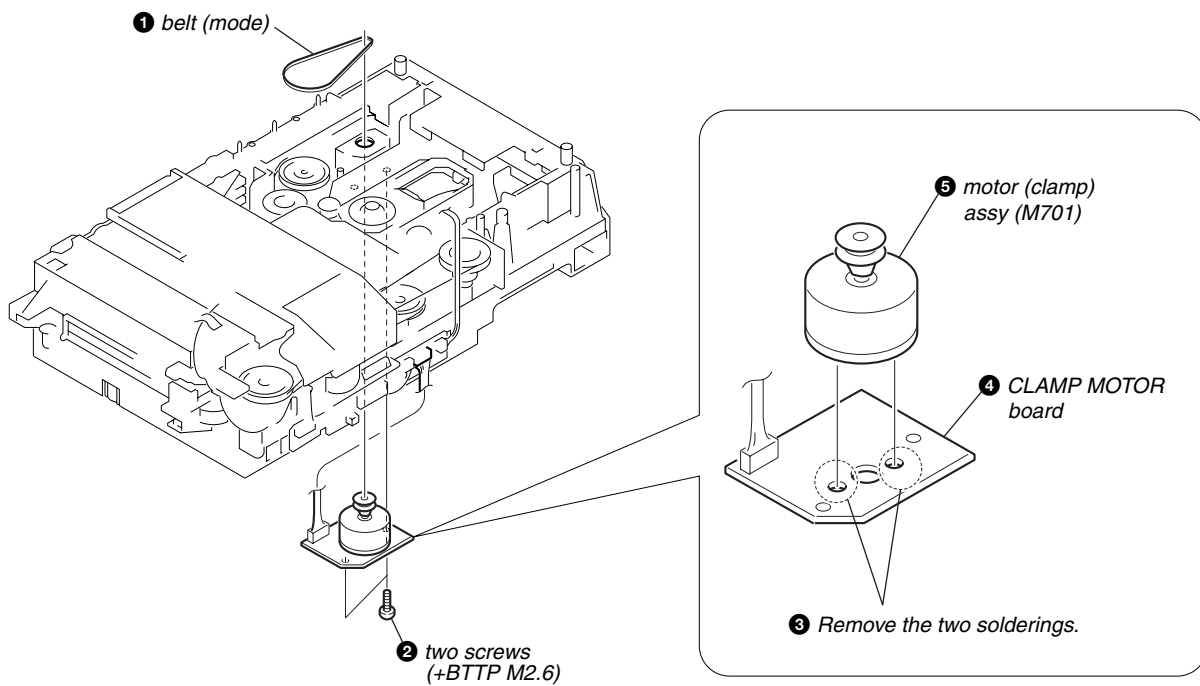

3-16. Fitting Base (Guide) Assy, Bracket (Chassis)

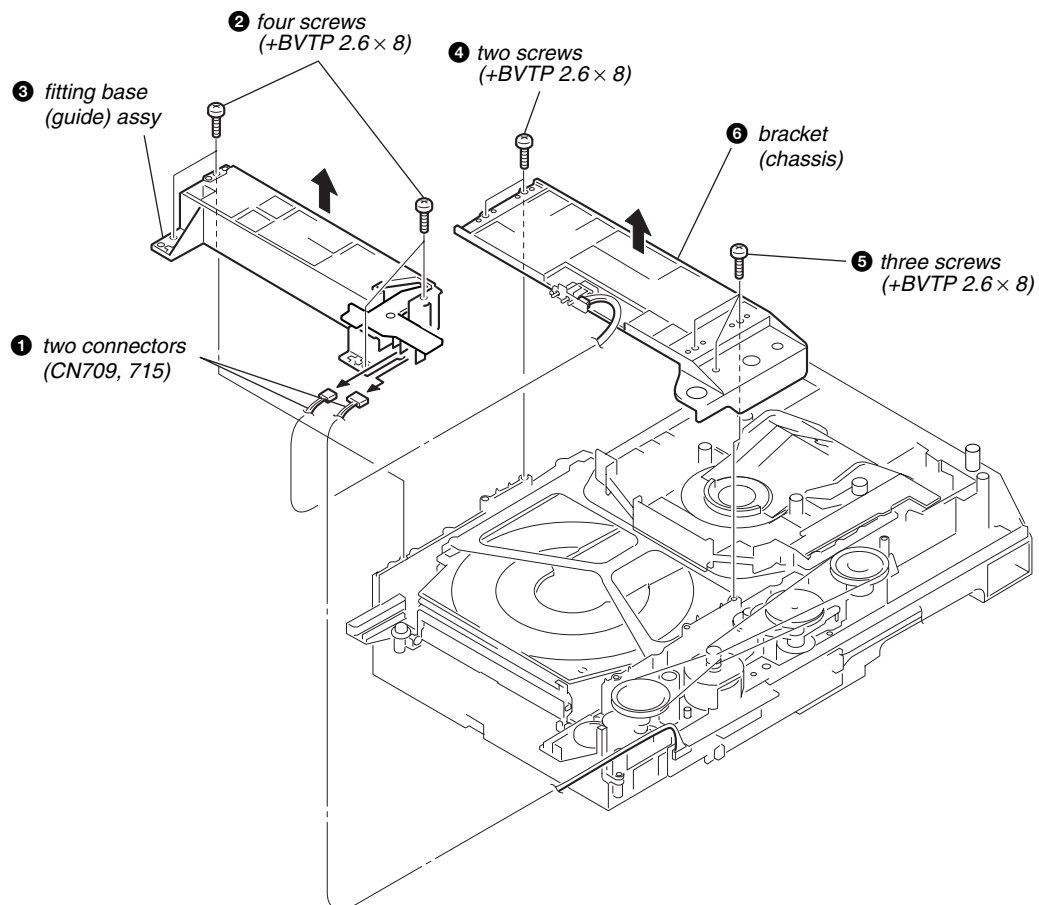

3-17. Tray (Sub)

- ❶ Rotating the pulley (LD), shift the slider (selection) in the arrow **A** direction.
- ❷ Rotating the pulley (mode) in the arrow direction, adjust the tray (sub) to be removed.
- ❸ Rotating the pulley (LD), shift the slider (selection) in the arrow **B** direction.
- ❹ Rotating the pulley (mode) in the arrow direction, remove the tray (sub) to be removed.

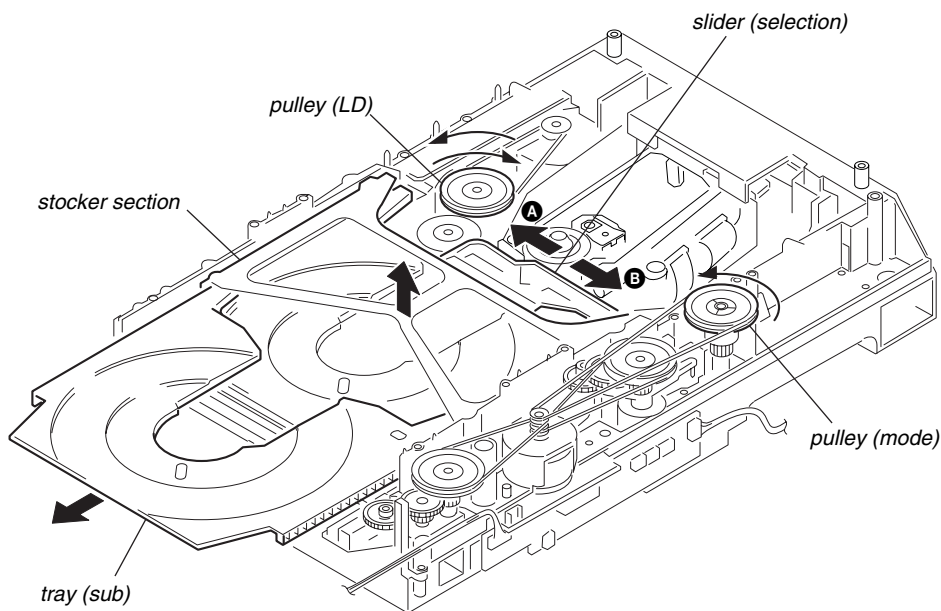

3-18. Chassis (Mold B)

PRECAUTION DURING CHASSIS (MOLD B) INSTALLATION

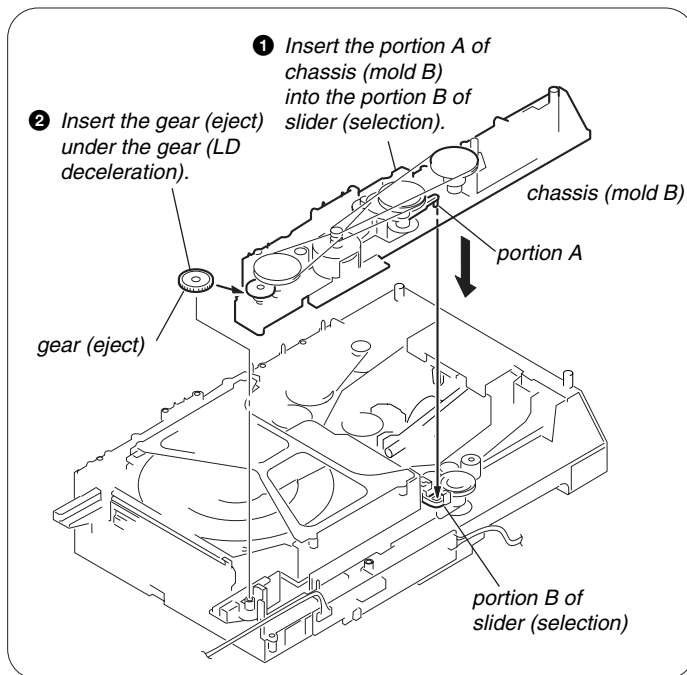
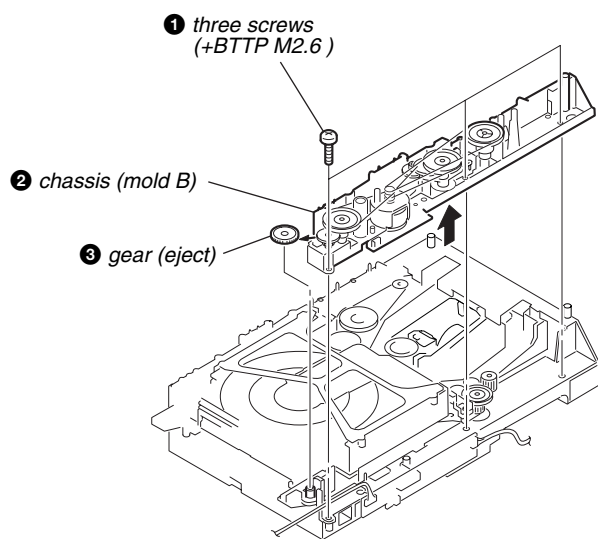

3-19. LOAD MOTOR Board, Motor (Loading) Assy (M702)

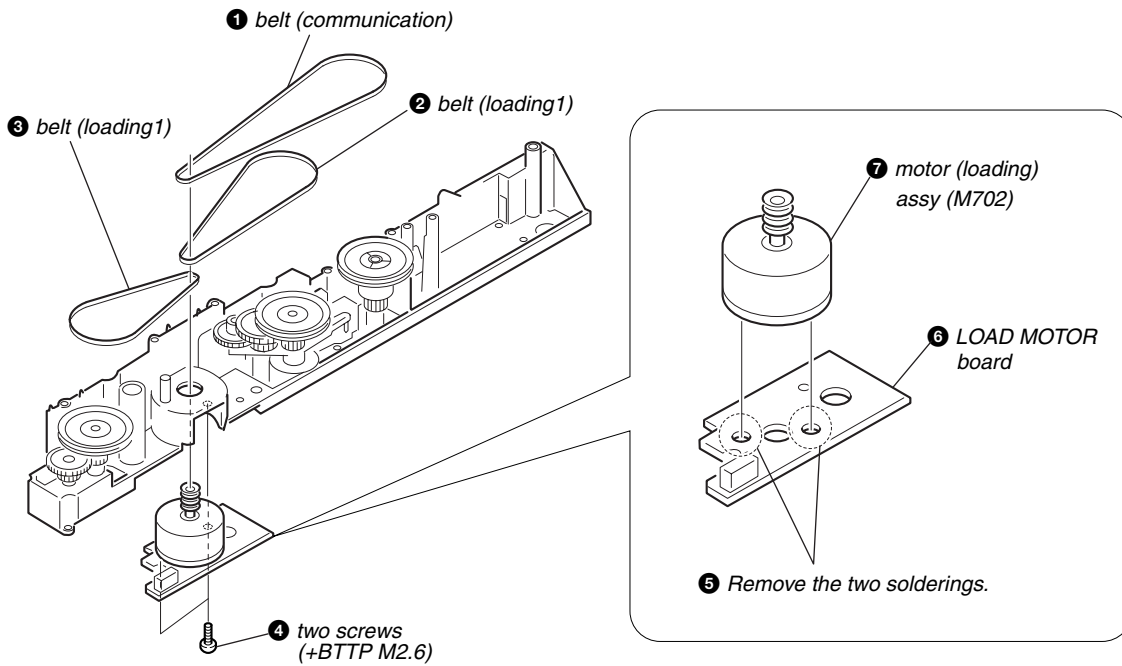

3-20. Stoker Section

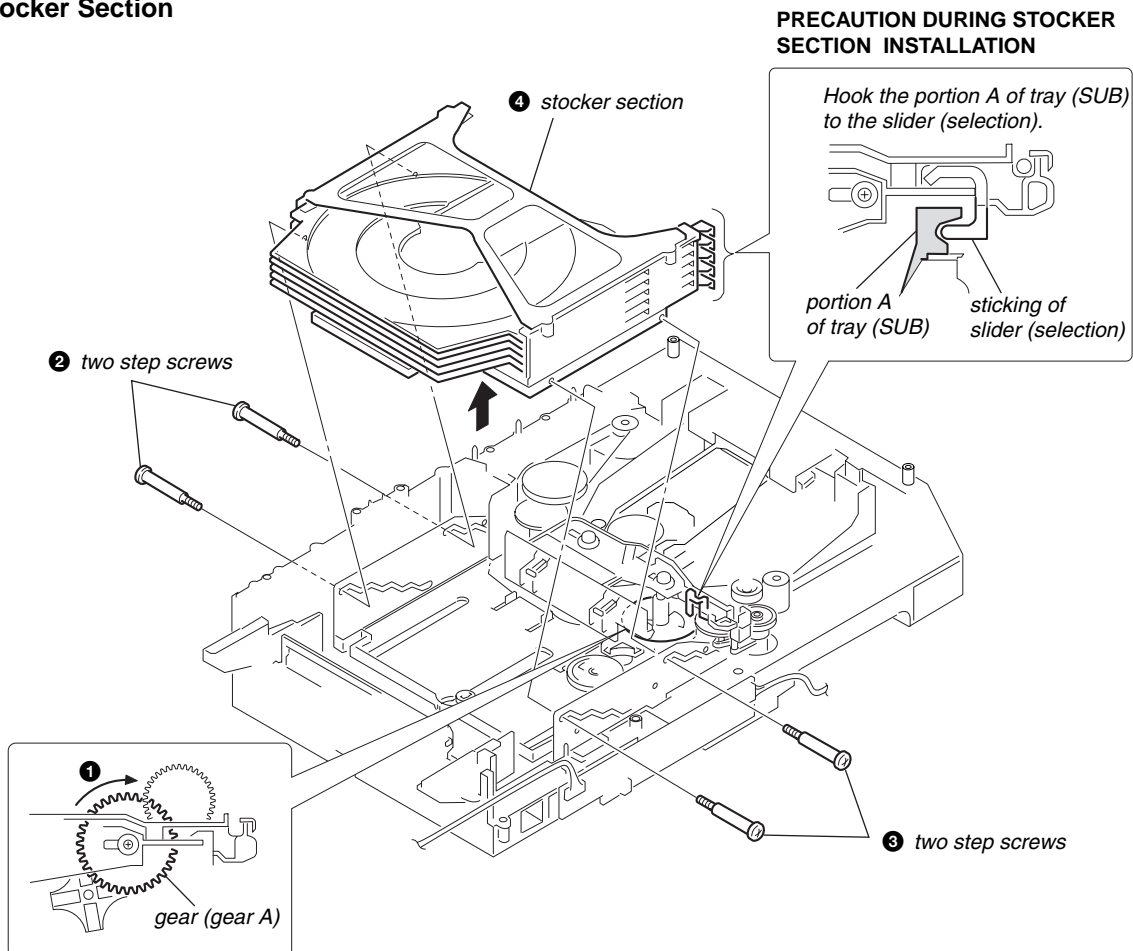

3-21. Slider (Selection), Tension Spring (Shutter), Slider (Shutter)

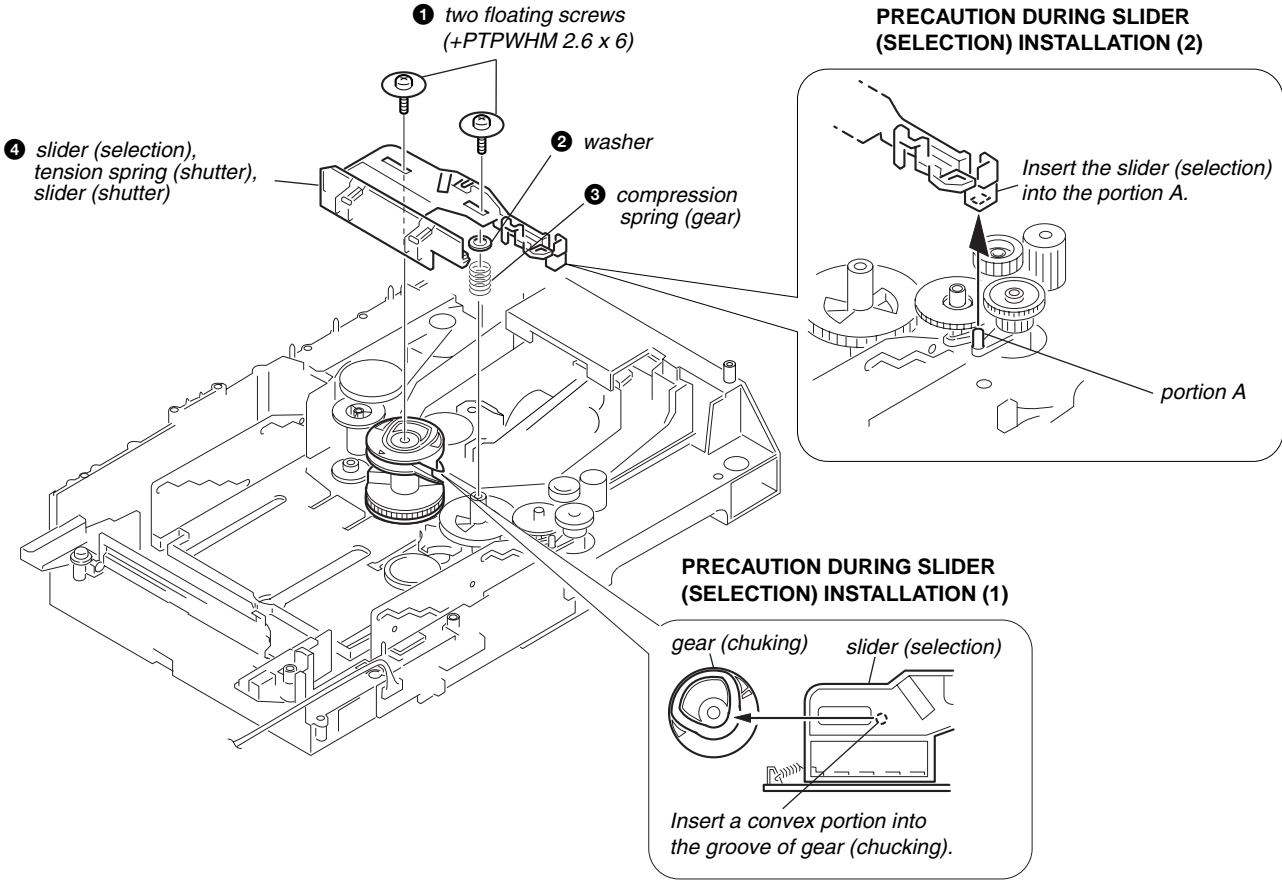

3-22. Gear (Gear A), Gear (Gear B), Gear (U/D Slider)

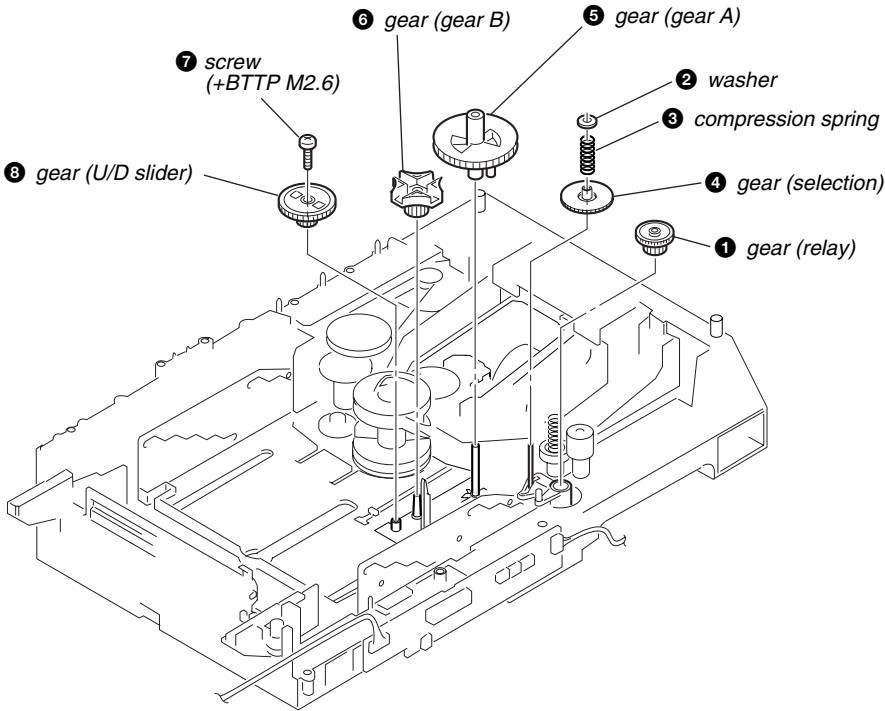

Precaution During Gear (Gear U/D Slider), Gear (Gear B), Gear (Gear A) Installation

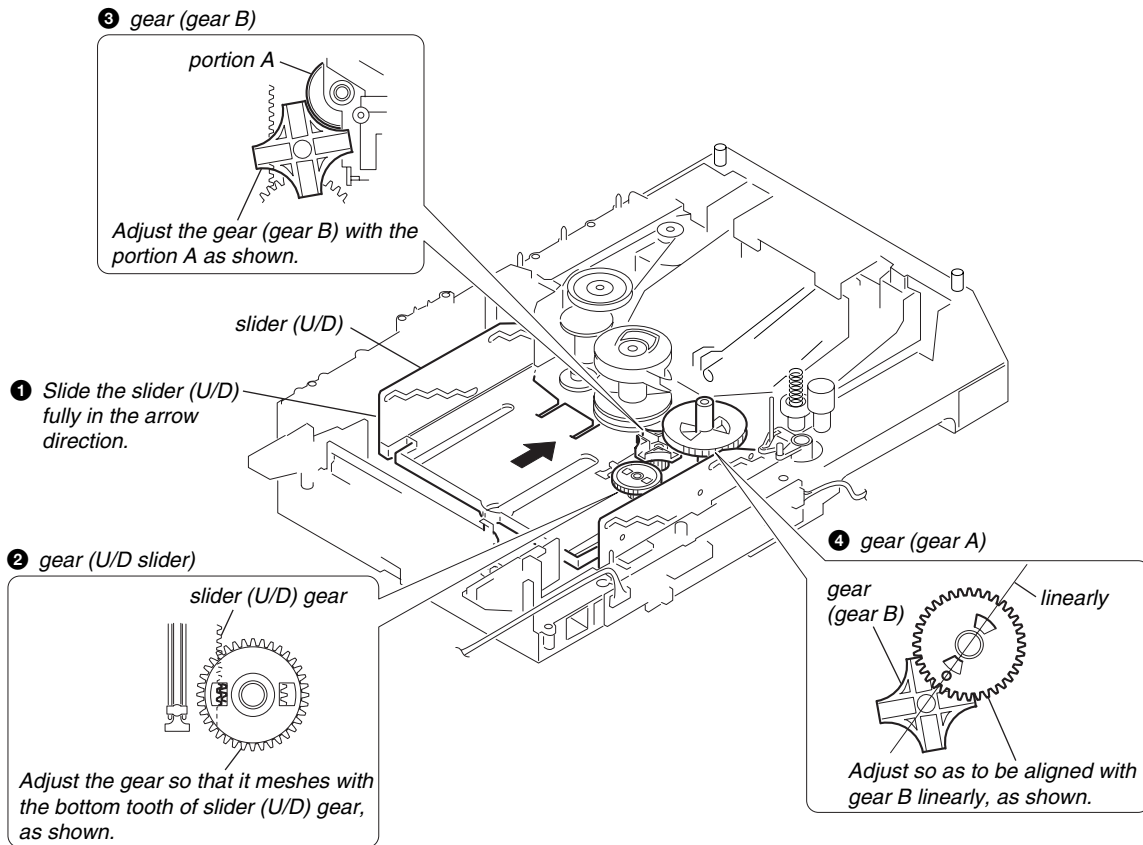

3-23. Gear (Chucking)

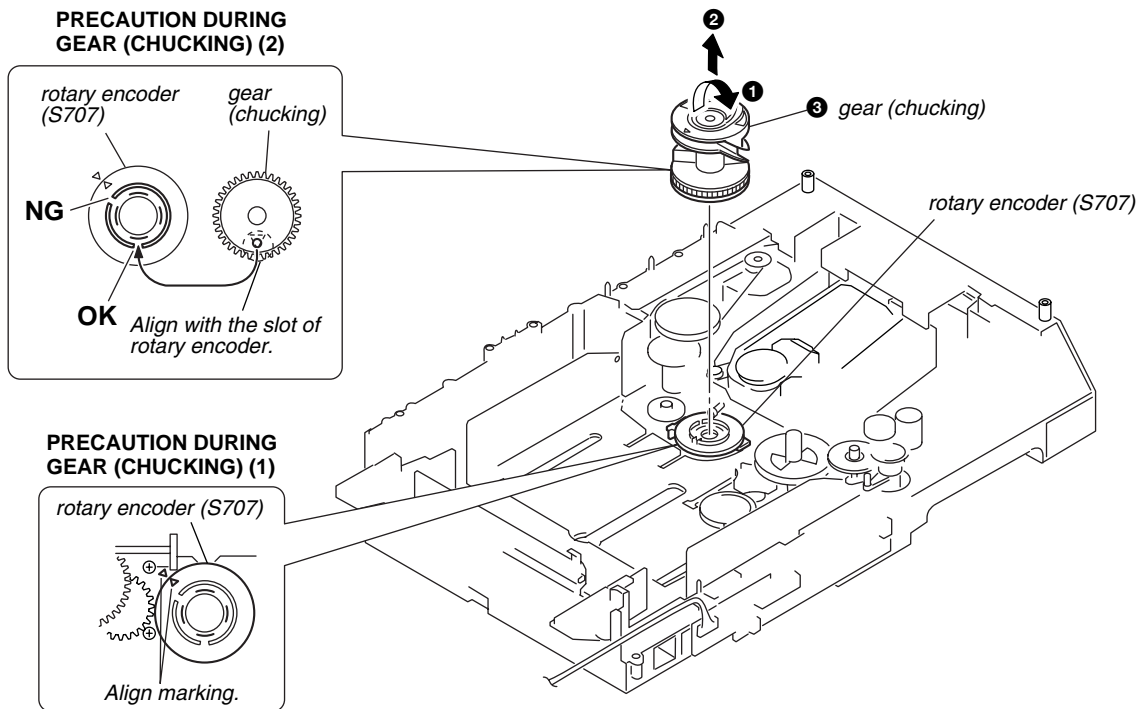

3-24. BD Board

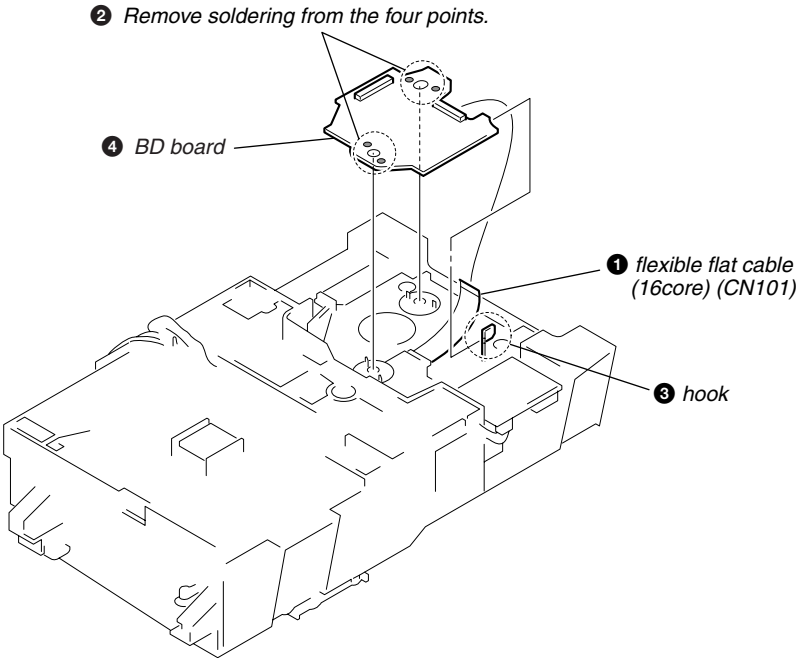

3-25. Optical Block Section

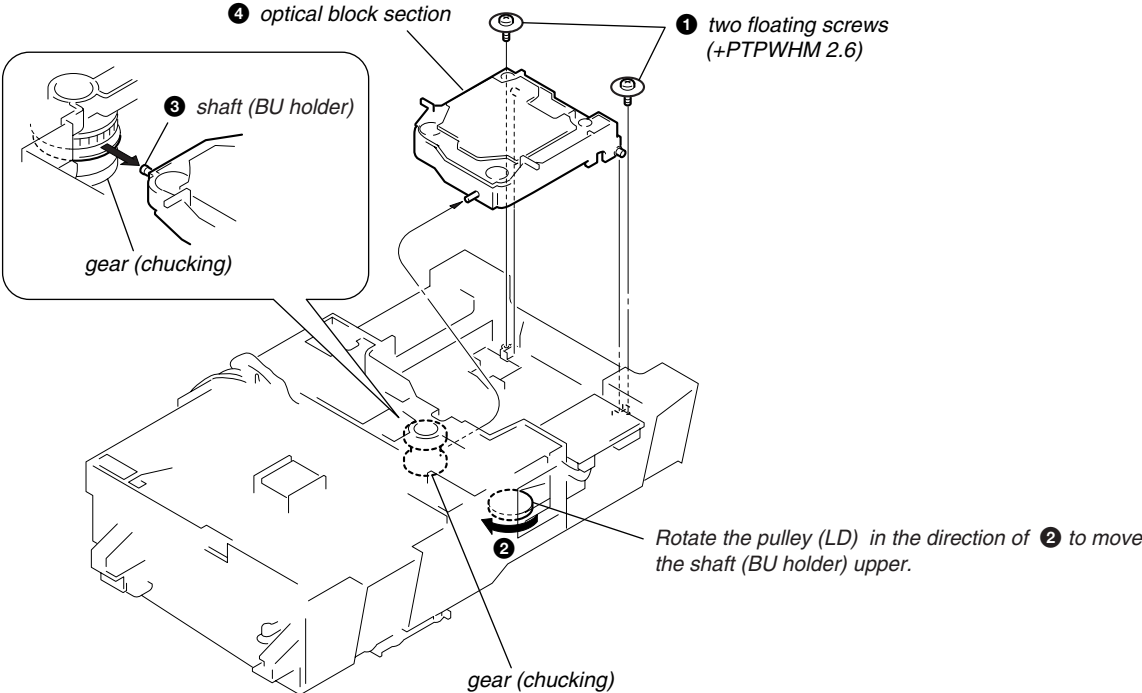

SECTION 4 TEST MODE

Setting the Test Mode

Procedure:

1. Press the **POWER** button to POWER on.
2. Press the **◀◀ AMS ▶▶** (DECK A), **SBM** and **◀◀ AMS ▶▶** (DECK B) buttons in order without releasing the button.
3. Turn the **◀◀ AMS ▶▶** (DECK B) knob to select the menu.
4. Press the **◀◀ AMS ▶▶** (DECK B) knob to execute the test mode.

Releasing the Test Mode

Procedure 1:

1. Turn the **◀◀ AMS ▶▶** (DECK B) knob to select the Ship Mode.
2. Press the **◀◀ AMS ▶▶** (DECK B) knob to execute the Ship Mode.
3. Press the **POWER** button to POWER off.

Procedure 2:

1. Press the **◀◀ AMS ▶▶** (DECK A), **SBM** and **◀◀ AMS ▶▶** (DECK B) buttons in order without releasing the button.
2. Press the **POWER** button to POWER off.

Contents of test mode

No.	Display	Function
1	SYS Version	System version display
2	CDR Version	CDR version display
3	BU Test	Deck A BU test mode
4	SERVICE	Deck A Service mode
5	Ship Mode	CD Shipment mode
6	FL ALL ON	Fluorescent indicator tube test
7	FL ALL OFF	Fluorescent indicator tube test
8	FL ITIMATSU	Fluorescent indicator tube test
9	LED CHECK	LED check
10	KEY CHECK	Keyboard check
11	RM CHECK	Remote commander check
12	CDR History	CDR error history display
13	Play Speed	Deck A x4 speed

System Version Display

Procedure:

1. Enter the test mode, then turn the **◀◀ AMS ▶▶** (DECK B) knob to display “SYS Version”, and press the **◀◀ AMS ▶▶** (DECK B) knob.
2. The system version is displayed.
3. To exit from this mode, turn the **◀◀ AMS ▶▶** (DECK B) knob to display “Ship Mode”, and press the **◀◀ AMS ▶▶** (DECK B) knob to execute the Ship Mode.
4. Press the **POWER** button to POWER off.

CDR Version Display

Procedure:

1. Enter the test mode, then turn the **◀◀ AMS ▶▶** (DECK B) knob to display “CDR Version”, and press the **◀◀ AMS ▶▶** (DECK B) knob.
2. The CDR version is displayed.
3. To exit from this mode, turn the **◀◀ AMS ▶▶** (DECK B) knob to display “Ship Mode”, and press the **◀◀ AMS ▶▶** (DECK B) knob to execute the Ship Mode.
4. Press the **POWER** button to POWER off.

BU Test Mode (Deck A)

Procedure:

1. Enter the test mode, then turn the **◀◀ AMS ▶▶** (DECK B) knob to display “BU Test”, and press the **◀◀ AMS ▶▶** (DECK B) knob.
2. “bdt S CURVE” is displayed. This test mode is used in the Electrical Adjustment section.
3. Turn the **◀◀ AMS ▶▶** (DECK B) knob. “bdt RAM READ”, “bdt RAM WRITE”, “bdt COMOUT”, “bdt FB TUNE” and “bdt ERR RATE” are displayed.
4. To exit from this mode, press the **MENU/NO** button and turn the **◀◀ AMS ▶▶** (DECK B) knob to display “bdt ERR RATE”.
5. Press the **◀◀ AMS ▶▶** (DECK A), **SBM** and **◀◀ AMS ▶▶** (DECK B) buttons in order without releasing the button.
6. Press the **POWER** button to POWER off.

Service Mode (Deck A)

Procedure:

1. Enter the test mode, then turn the **◀◀ AMS ▶▶** (DECK B) knob to display “SERVICE”, and press the **◀◀ AMS ▶▶** (DECK B) knob.
2. “SERVICE MODE” is displayed.
3. Press the **ERASE** button, “SLED OUT” is displayed and the sled moves to the outermost direction. When the **ERASE** button is released, “SLED STOP” is displayed and the sled stops.
4. Press the **FINALIZE** button, “SLED IN” is displayed and the sled moves to the innermost direction. When the **FINALIZE** button is released, “SLED STOP” is displayed and the sled stops.
5. To exit from this mode, press the **◀◀ AMS ▶▶** (DECK A), **SBM** and **◀◀ AMS ▶▶** (DECK B) buttons in order without releasing the button.
6. Press the **POWER** button to POWER off.

Note: Always move the pick-up to the most inside position when exiting from this mode.

Ship Mode

Procedure:

1. Enter the test mode, then turn the **◀◀ AMS ▶▶** (DECK B) knob to display “Ship Mode”, and press the **◀◀ AMS ▶▶** (DECK B) knob.
2. “Push POWER!” is displayed.
3. Press the **POWER** button to POWER off.

FL ALL ON Mode

Procedure:

1. Enter the test mode, then turn the **◀◀ AMS ▶▶** (DECK B) knob to display “FL ALL ON”, and press the **◀◀ AMS ▶▶** (DECK B) knob.
2. All segments of fluorescent indicator tube and LED turn on.
3. Press the **MENU/NO** button, then “FL ALL ON” is displayed again.
4. To exit from this mode, turn the **◀◀ AMS ▶▶** (DECK B) knob to display “Ship Mode”, and press the **◀◀ AMS ▶▶** (DECK B) knob to execute the Ship Mode.
5. Press the **POWER** button to POWER off.

FL ALL OFF Mode

Procedure:

1. Enter the test mode, then turn the [◀◀ AMS ▶▶] (DECK B) knob to display “FL ALL OFF”, and press the [◀◀ AMS ▶▶] (DECK B) knob.
2. All segments of fluorescent indicator tube and LED turn off.
3. Press the [MENU/NO] button, then “FL ALL OFF” is displayed again.
4. To exit from this mode, turn the [◀◀ AMS ▶▶] (DECK B) knob to display “Ship Mode”, and press the [◀◀ AMS ▶▶] (DECK B) knob to execute the Ship Mode.
5. Press the [POWER] button to POWER off.

FL ITIMATSU Mode

Procedure:

1. Enter the test mode, then turn the [◀◀ AMS ▶▶] (DECK B) knob to display “FL ITIMATSU”, and press the [◀◀ AMS ▶▶] (DECK B) knob.
2. Checkered patterns of segments are displayed.
3. Press the [MENU/NO] button, then “FL ITIMATSU” is displayed again.
4. To exit from this mode, turn the [◀◀ AMS ▶▶] (DECK B) knob to display “Ship Mode”, and press the [◀◀ AMS ▶▶] (DECK B) knob to execute the Ship Mode.
5. Press the [POWER] button to POWER off.

LED Check Mode

Procedure:

1. Enter the test mode, then turn the [◀◀ AMS ▶▶] (DECK B) knob to display “LED CHECK”, and press the [◀◀ AMS ▶▶] (DECK B) knob.
2. Turn the [◀◀ AMS ▶▶] (DECK A) or (DECK B) knob clockwise. The green LED (DISC 1) turns on, then the orange LED (DISC 1) turns on. The each orange LED turns on after the green LED from DISC 1 to DISC 5. The LED (SBM) turns on at last. Counterclockwise rotation gives a performance in reverse order.
3. Press the [MENU/NO] button, then “LED CHECK” is displayed again.
4. To exit from this mode, turn the [◀◀ AMS ▶▶] (DECK B) knob to display “Ship Mode”, and press the [◀◀ AMS ▶▶] (DECK B) knob to execute the Ship Mode.
5. Press the [POWER] button to POWER off.

KEY Check Mode

Procedure:

1. Enter the test mode, then turn the [◀◀ AMS ▶▶] (DECK B) knob to display “KEY CHECK”, and press the [◀◀ AMS ▶▶] (DECK B) knob.
2. “Got 0 keys” is displayed.
3. Press the buttons, and when all the buttons are pressed (without the [POWER] button), “Got 35 keys” will be displayed.
4. To exit from this mode, press the [◀◀ AMS ▶▶] (DECK A), [SBM] and [◀◀ AMS ▶▶] (DECK B) buttons in order without releasing the button.
5. Press the [POWER] button to POWER off.

Remote Commander Check

Procedure:

1. Enter the test mode, then turn the [◀◀ AMS ▶▶] (DECK B) knob to display “RM CHECK”, and press the [◀◀ AMS ▶▶] (DECK B) knob.
2. Press the [▶] key on the remote commander, then “Got PlayCom” is displayed.
3. Press the [MENU/NO] button, then “RM CHECK” is displayed again.
4. To exit from this mode, turn the [◀◀ AMS ▶▶] (DECK B) knob to display “Ship Mode”, and press the [◀◀ AMS ▶▶] (DECK B) knob to execute the Ship Mode.
5. Press the [POWER] button to POWER off.

CDR History Display

Procedure:

1. Enter the test mode, then turn the [◀◀ AMS ▶▶] (DECK B) knob to display “CDR History”, and press the [◀◀ AMS ▶▶] (DECK B) knob.
2. “00 #####” is displayed as the first error history.
3. Turn the [◀◀ AMS ▶▶] (DECK B) knob to select the error history. The number of error histories is ten in all. (Refer to “Contents of CDR error history”.)
4. Press the [MENU/NO] button, then “CDR History” is displayed again.
5. To exit from this mode, turn the [◀◀ AMS ▶▶] (DECK B) knob to display “Ship Mode”, and press the [◀◀ AMS ▶▶] (DECK B) knob to execute the Ship Mode.
6. Press the [POWER] button to POWER off.

Play Speed Selection Mode (Deck A)

Procedure:

1. Enter the test mode, then turn the [◀◀ AMS ▶▶] (DECK B) knob to display “Play Speed”, and press the [◀◀ AMS ▶▶] (DECK B) knob.
2. “x4 Play” is displayed. If a CD is in the deck A, pressing the [▶] button executes the 4 times speed playback.
3. Press the [■] button to stop the playback.
4. Press the [MENU/NO] button, then “Play Speed” is displayed again.
5. To exit from this mode, turn the [◀◀ AMS ▶▶] (DECK B) knob to display “Ship Mode”, and press the [◀◀ AMS ▶▶] (DECK B) knob to execute the Ship Mode.
6. Press the [POWER] button to POWER off.

Contents of CDR error history

display(example)

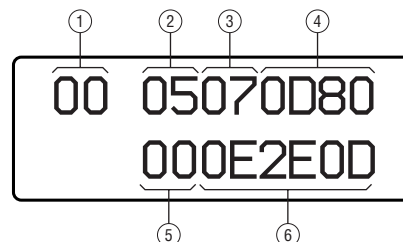

(hexadecimal)

- ① Order of the error history
00 to 09: ten error histories in all
- ② Error contents
01: unable to focus on
02: Q code/ATIP discontinuous (several frames preceding)
03: Q code/ATIP unreadable
04: search taking more than sixteen seconds
05: focus failure
06: sled over run
07: not passing by start time to write
08: audio buffer over
09: sync failure
0A: Spindle lock taking more than 8 seconds

example : 05 is focus failure

RCD-W500C

③ Operation mode

bit 7: Speed

- 0: normal speed
- 1: x4 speed

bit 6 to bit 0: Number of inner condition

- 01: POWER off condition/during shift to POWER on
- 02: POWER off and shipment setting/during shift to POWER off and shipment setting
- 03: stop condition/during stop
- 04: during start up of servo
- 05: during TOC reading and others
- 06: during CD TEXT reading
- 07: during standby(waiting for command from the CD system)/during search
- 08: during playback
- 09: during manual search(playback)

- 0A: during pause
- 0B: during manual search(pause)
- 0C: during OPC
- 0D: recording standby/during recording pause (enable to shift to recording)
- 0E: during recording
- 0F: unable to record (waiting for shift to being recordable)
- 10: PMA updating
- 11: during operation of unfinalize
- 12: during operation of finalize
- 13: PMA erasing
- 14: emergency
- 15: recording preparation
- 16: recording end

⑤ Write POWER (integer of mW x 10, available during write processing)

examples: 00 means unavailable
(when ③ operation mode is not recording)
: A3 means 163(decimal), i.e. 16.3 mW

⑥ ATIME (min)/(sec)/(frame)

example: 0E, 2E, 0D means 14 : 46 : 13

Abbreviations:

- ATIP : Absolute Time In Pre-groove
- OPC : Optimum Power Control
- PMA : Program Memory Area

examples :

HEX	bit	7	6	5	4	3	2	1	0	Operation mode
07		0	0	0	0	0	1	1	1	normal speed, during standby(waiting for command from the CD system)/during search
91		1	0	0	1	0	0	0	1	x4 speed, during operation of unfinalize

④ Start time of read in(compression method)

bit 15 to bit 13 : (min)

- 0: 97 min
- 1: 96 min
- 2: 95 min
- 7: others

bit 12 to bit 7: (sec)

bit 6 to bit 0: (frame)

examples :

HEX	bit	15	14	13	12	11	10	9	8	7	6	5	4	3	2	1	0	Start time of read in
0D, 80		0	0	0	0	1	1	0	1	1	0	0	0	0	0	0	0	97 : 27 : 00
11, 16		0	0	0	1	0	0	0	1	0	0	0	1	0	1	1	0	97 : 34 : 22

SECTION 5 ELECTRICAL ADJUSTMENTS

CD SECTION (DECK A)

Note :

1. CD Block is basically designed to operate without adjustment. Therefore, check each item in order given.
2. Use YEDS-18 disc (3-702-101-01) unless otherwise indicated.
3. Use an oscilloscope with more than 10MΩ impedance.
4. Clean the object lens by an applicator with neutral detergent when the signal level is low than specified value with the following checks.

S Curve Check

Connection :

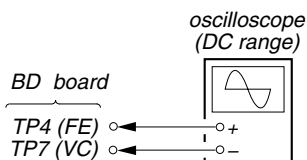

Procedure :

1. Connect an oscilloscope to test point TP4 (FE) and TP7 (VC) on the BD board.
2. Turn the power on.
3. Load the disc (YEDS-18).
4. Enter the test mode, select the BU Test and press the **AMS** (DECK B) knob to display "bdt S CURVE".
5. Press the **AMS** (DECK B) knob. "LD AL" is displayed and playback starts automatically.
6. Check the oscilloscope waveform (S-curve) is symmetrical between A and B.
7. Press the **MENU/NO** button to stop playback.
8. Exit from the test mode.
(Refer to the TEST MODE Section)

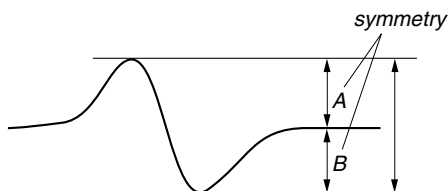

Note: Try to measure several times to make sure than the ratio of A : B or B : A is more than 10 : 7.

Checking Location : BD board (Side B)(See page 24)

RF Level Check

Connection :

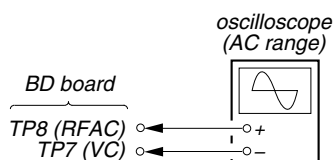

Procedure :

1. Connect an oscilloscope to TP8 (RFAC) and TP7 (VC).
2. Turn the power on.
3. Load the disc (YEDS-18) and playback the number five track.
4. Confirm that oscilloscope waveform is clear and check RF signal level is correct or not.

Note: A clear RF signal waveform means that the shape "φ" can be clearly distinguished at the center of the waveform.

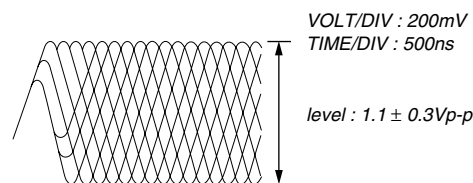

Checking Location : BD board (Side B)(See page 24)

E-F Balance Adjustment

Connection :

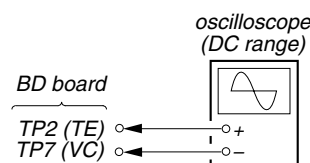

Procedure:

1. Connect an oscilloscope to TP2 (TE) and TP7 (VC) on the BD board.
2. Turn the power on.
3. Load the disc (YEDS-18) and playback the number five track.
4. Enter the Service Mode. (see page 20) Press the **INPUT** button until "TRV ON" is displayed. (The tracking servo and the sledding servo are turned off.)
5. Check the level B of the oscilloscope waveform. Rotate the RV101 on the BD board and adjust so that the A (DC voltage) of the center of the traverse waveform becomes 0 volt.

Traverse Waveform

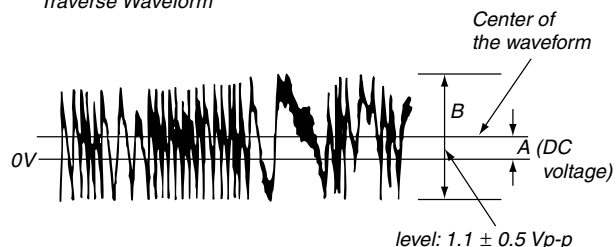

6. Press the **INPUT** button until "TRV OFF" is displayed and the tracking servo and the sledding servo are turned on. Confirm that the C (DC voltage) is almost equal to the A (DC voltage).

Traverse Waveform

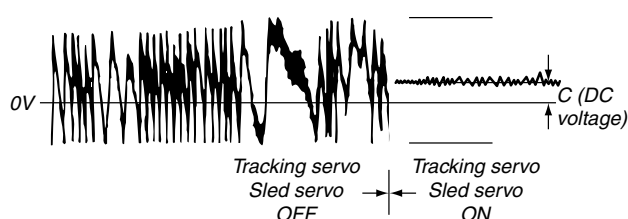

7. Exit from the test mode. (see page 20)

Checking Location : BD board (Side B)(See page 24)

Adjustment at Replacement of CD Base Unit (BU-30BBD61M)

Perform the E-F Balance Adjustment at replacement of CD base unit (BU-30BBD61M).

RCD-W500C

Adjustment and Checking Location:

[BD BOARD] — SIDE B —

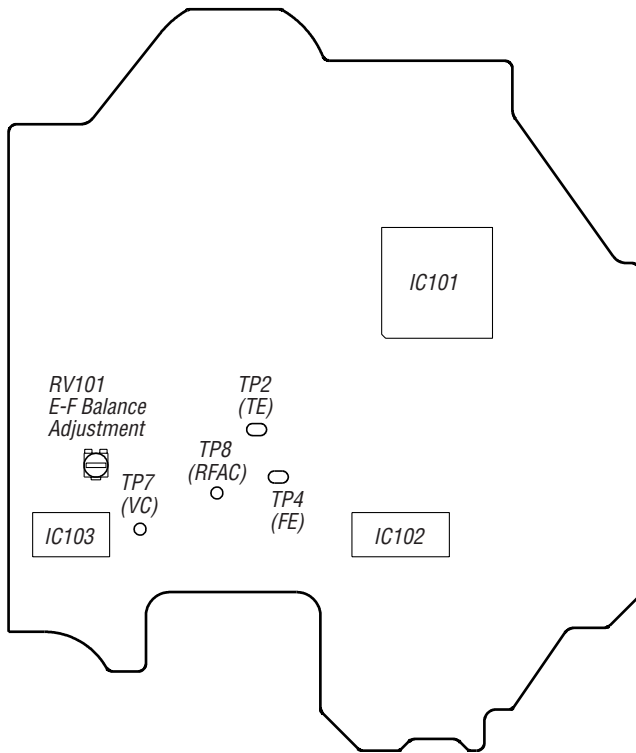

CD-R/RW SECTION

* The following is the method of locating the faulty point and electrical adjustment.

1. Connection and Setting of Programs

1-1. Connection

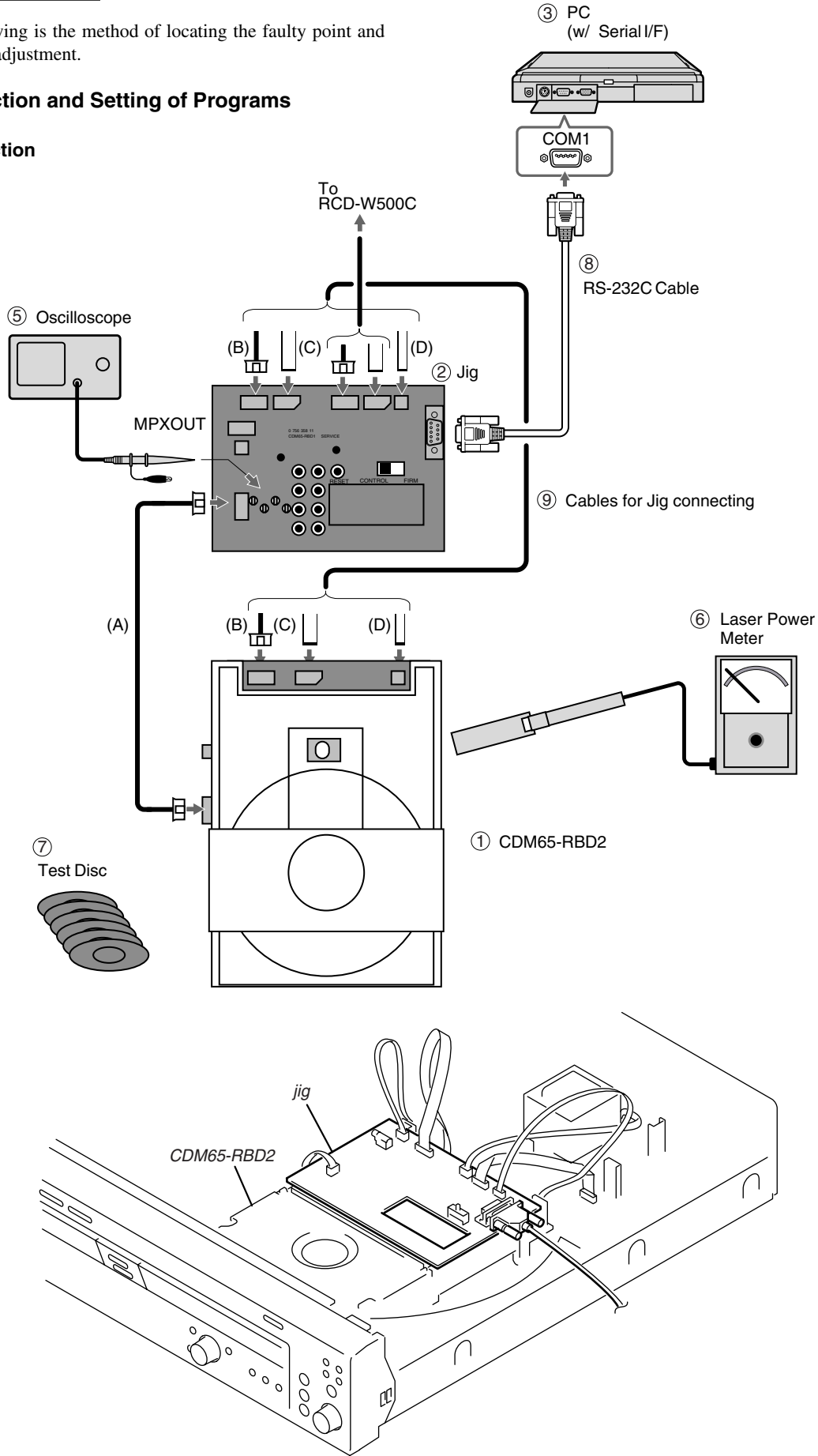

▲ Fig. Position of Jig (Set the jig after removing the cover of CDM65-RBD2)

1-2. Equipments to prepare

- ① Test Object Both RBD2 and CDM65-RBD2 shall be tested.
RBD2 : Flash Memory Writing of of
Circuit Test by Self-diagnostics
CDM65-RBD2 : Electrical Adjustment
Performance Test
- ② Jig (With ⑨ Cables, Parts No.J-2501-223-A)
- ③ PC Windows95/98/2000/Me with COMport (RS-232C)
- ④ Programs TeraTerm Pro + Service macro
- ⑤ Oscilloscope More than 150MHz
- ⑥ Laser Power Meter LEADER LPM-8001 (Parts No.J-2501-046-A)
- ⑦ Test Disc

PATD-012 : (Parts No.4-225-203-1)	Adjustment for Playback	(CD,CD-R)
TCD-W091W : (Parts No.J-2501-226-A)	Adjustment for Playback	(CD-RW)
CRM74 (Blank CD-R) :	Adjustment and Check for Recording	(CD-R)
CWM74 (Blank CD-RW) :	Check for Recording	(CD-RW)
TCD-W032W : (Parts No.J-2501-227-A)	Defocus tolerance	(CD-RW)
- ⑧ RS-232C Cable

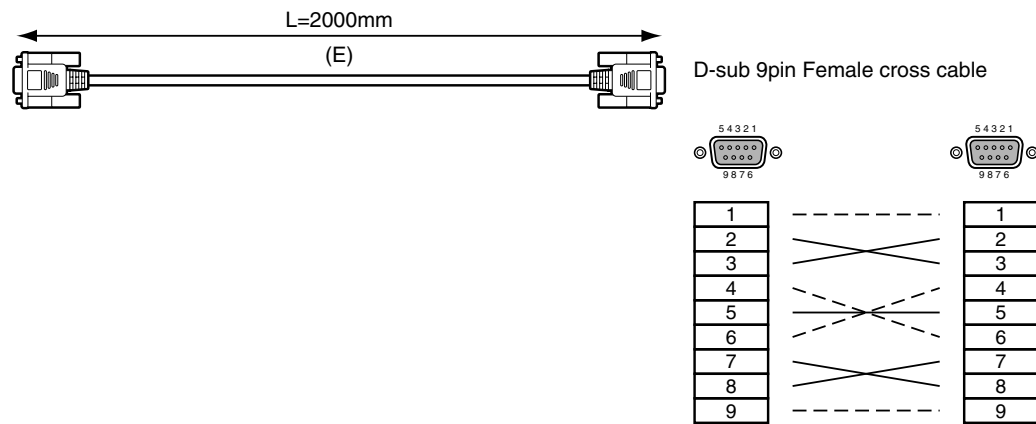

⑨ Cables for Jig connecting

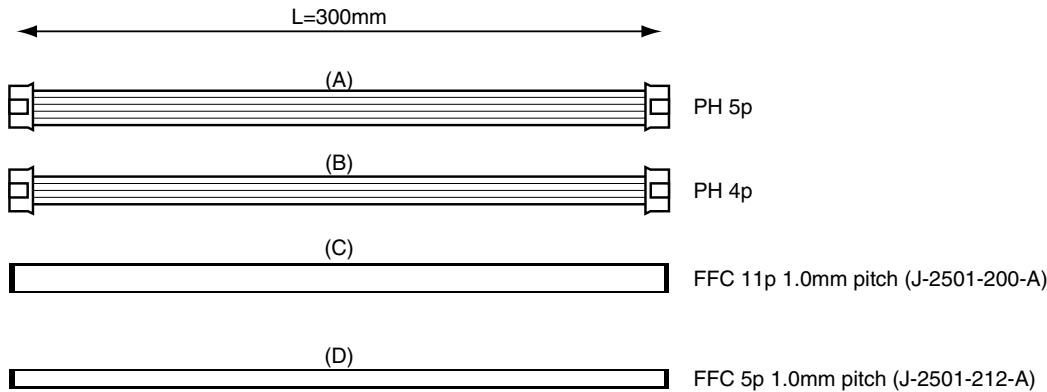

1-3. Setting of Programs (Tera Term Pro and Service macro)

* Confirmation of System (Windows 98 is used in this explanation) Preparation for Terminal software

1) Set up the serial port from OS.

a) Select Start → Settings → Control Panel and select System → Device manager → Communication Port (COMn)
(see Fig. 1-1)

* Specify the COM port that connected with JIG of CDM65.

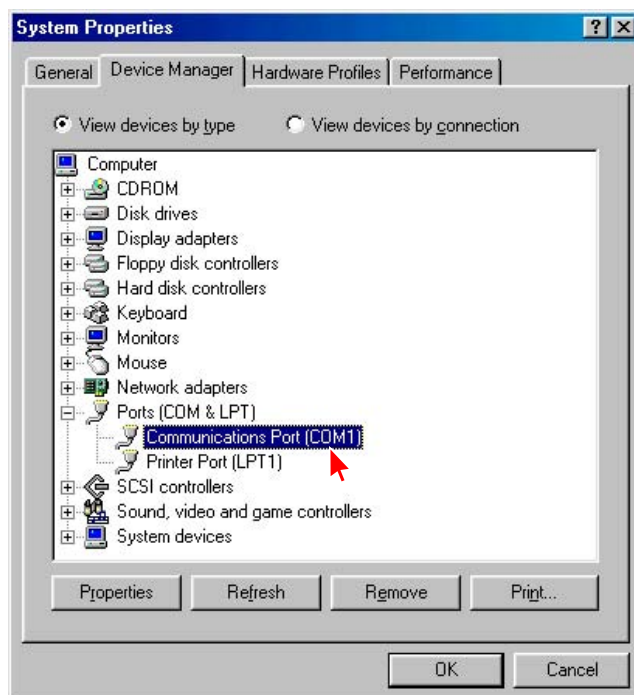

▲ Fig. 1-1

b) Double click COMn (as you connect to the Jig-CDM65)
Set the parameters as below.

Bits per second : 38400
Data bits : 8
Parity : non
Stop bits : 1
Flow control : hardware
(see Fig.1-2)

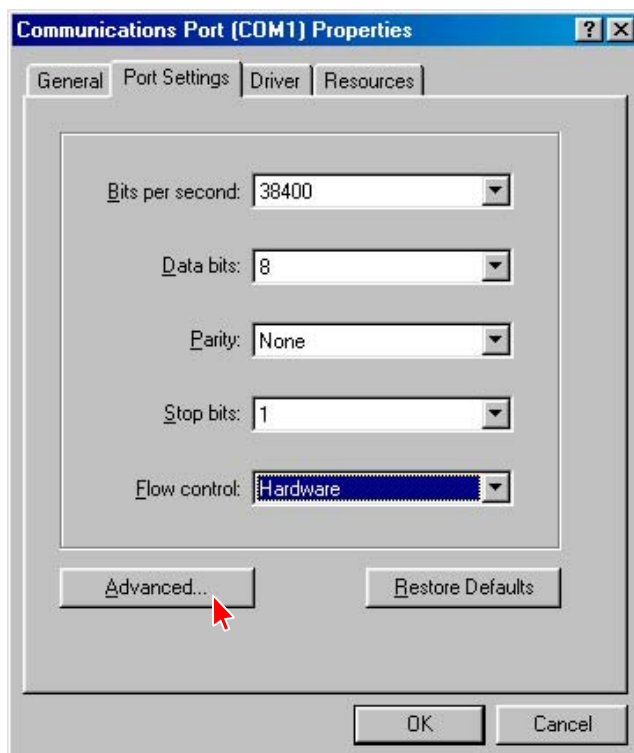

▲ Fig. 1-2

- c) Press “Advanced...” button (see Fig.1-2)
Remove the check “Use FIFO buffers ...”
(see Fig.1-3)

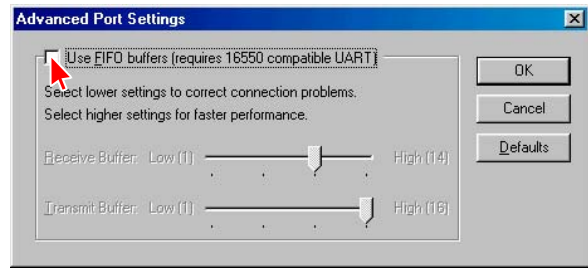

▲ Fig. 1-3

- 2) Unzip the file “ttermp23.zip” by PC.
(The file “ttermp23.zip” is distributed together with the service manual.)
- 3) After unzip the files, you can find setup.exe.
Double click the setup.exe.
Please install as the installer is.
Do not change the directory that files are installed. (use default)
- 4) Unzip the file “030416_Service.zip” by PC.
Copy all “ttl” file and “FUNC” folder which are contained in “030416_Service” and paste them in the “Ttermpro” file as below.
(The file “030416_Service.zip” is distributed together with the service manual.)

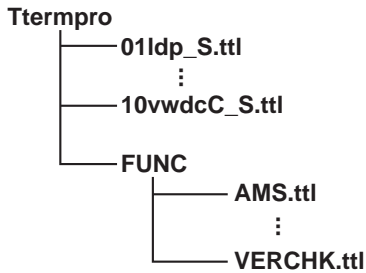

▲ Fig. 1-4

Note : Do not change the directory path.

- 5) Start-up the TeraTermPro
Double click the ttermpro.exe.
- 6) Set up the TeraTermPro (IMPORTANT!!)
a) Select Setup → Serial Port... and set the parameters as below.

Port : (As you connect to the Jig-CDM65)
Baud rate : 38400
Data : 8 bit
Parity : none
Stop : 1 bit
Flow control : hardware
Transmit delay : 0 msec/char 10 msec/line

After settings, press “OK” button. (see Fig.1-5)

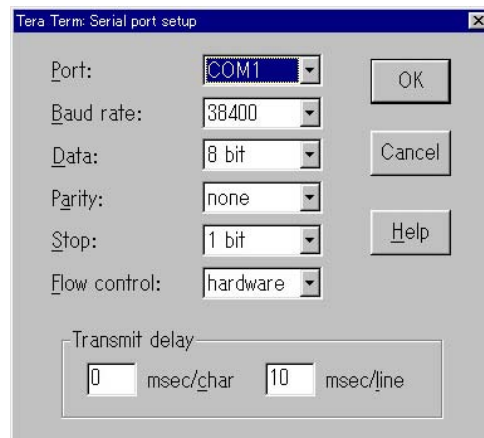

▲ Fig. 1-5

- b) Terminal setup
Set the parameters as below.

New-line receive : CR
transmit : CR

After settings, press “OK” button. (see Fig.1-6)

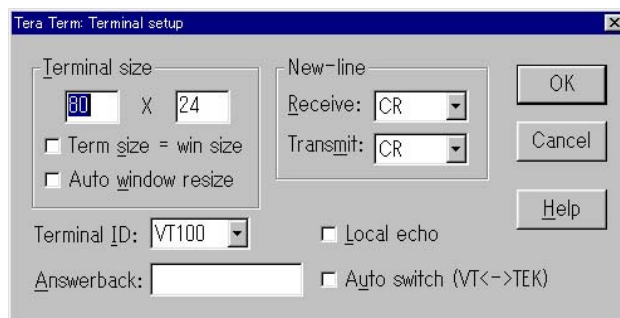

▲ Fig. 1-6

- c) General setup
Select the language and press “OK” button. (see Fig.1-7)



▲ Fig. 1-7

- d) Saving the setup
Select Setup → Save setup... and save as teraterm.ini in the Ttermpro directory. (see Fig.1-8)

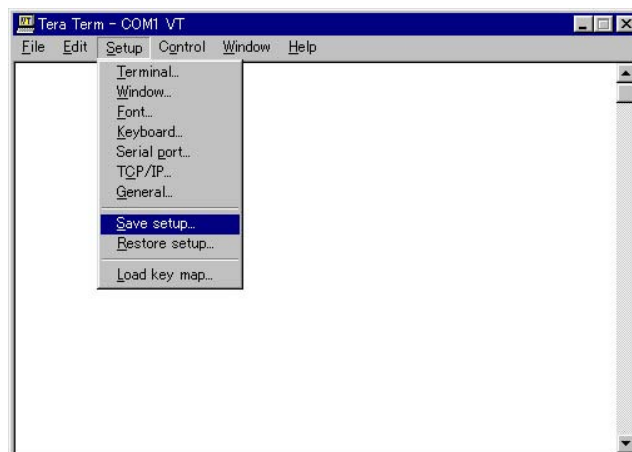

▲ Fig. 1-8

- 7) Connect the JIG and CDM65.
- 8) Confirm the S510 on JIG is ‘CONTROL’.
- 9) Power on the CDM65 and press SW101(RESET) on JIG.

“CDM65-RBD1 has connected with this PC (^)” is displayed. (see Fig.1-9)

If above message is not displayed, you may have some mistakes. Please confirm previous setting procedures again.

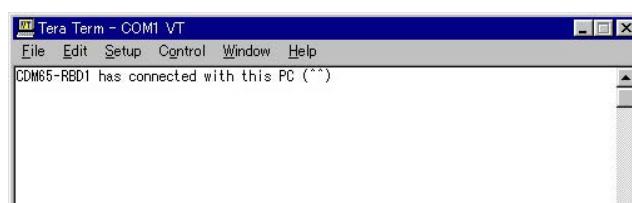

▲ Fig. 1-9

2. Repair Works That Require Electrical Adjustment

In the case of repair works as shown below, electrical adjustment is required.

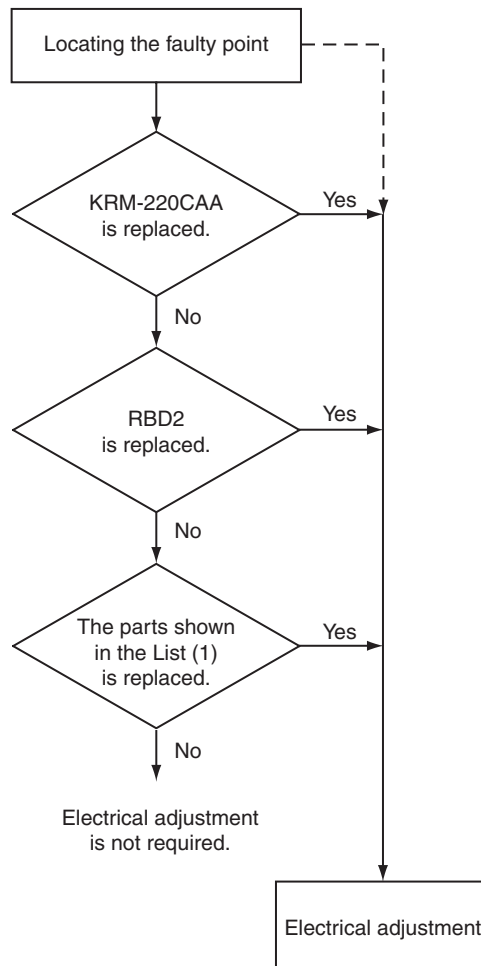

List (1) : IC101, IC103, IC171, IC201, IC502

3. Locating the Faulty Point

3-1. Laser Power Check

- 1) Select the menu as follows. Control → Macro, and select LDPtestL_S.ttl.
Press “Open”. (Fig. 3-1, 3-2)



▲ Fig. 3-1

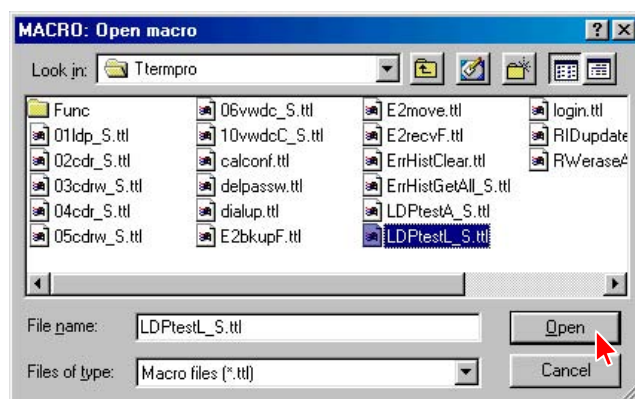

▲ Fig. 3-2

- 2) Press the “RESET” button (SW101) of the jig as prompted by the display.
- 3) Place probe of a laser power meter in the specified position following the display as shown in Fig. 3-3. (See Fig. 3-3-a)



▲ Fig. 3-3

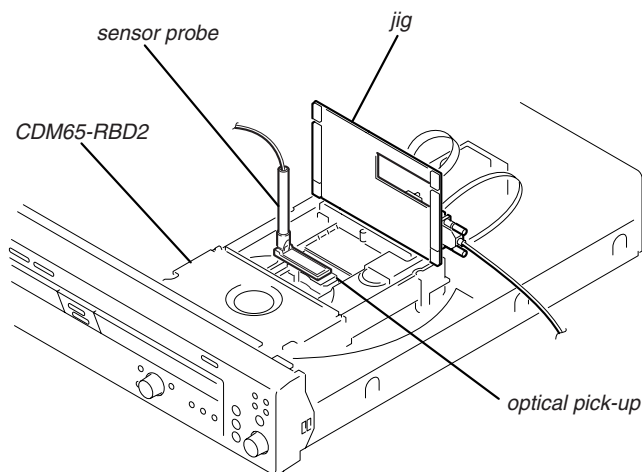

▲ Fig. 3-3-a

Note : Do not add stress to an optical pick-up.

- 4) When the display shown in Fig. 3-4 appears, set the Range of a laser power meter to “1 mW” and press “OK”.



▲ Fig. 3-4

- 5) Check that the laser power meter reading satisfies the following requirement. When the laser power satisfies the required specification, press “OK”. (Fig. 3-5)

LEADER LPM-8001 : 0.76 to 0.86 mW

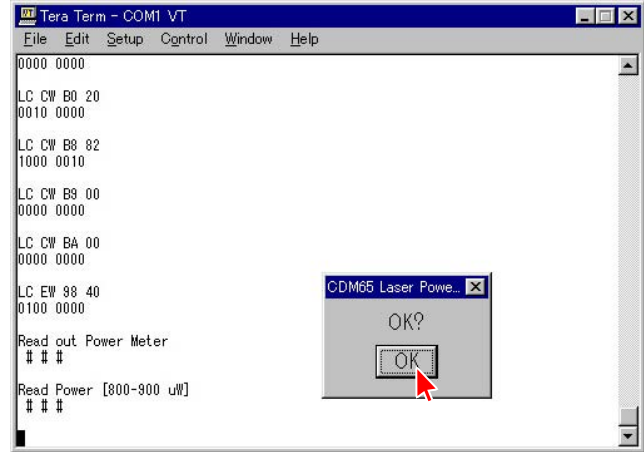

▲ Fig. 3-5

- 6) When the display shown in Fig. 3-6 appears, set the Range of a laser power meter to “10 mW” and press “OK”.



▲ Fig. 3-6

- 7) Check that the laser power meter reading satisfies the following requirement. When the laser power satisfies the required specification, press “OK”. (Fig. 3-7)

LEADER LPM-8001 : 4.5 to 4.7 mW

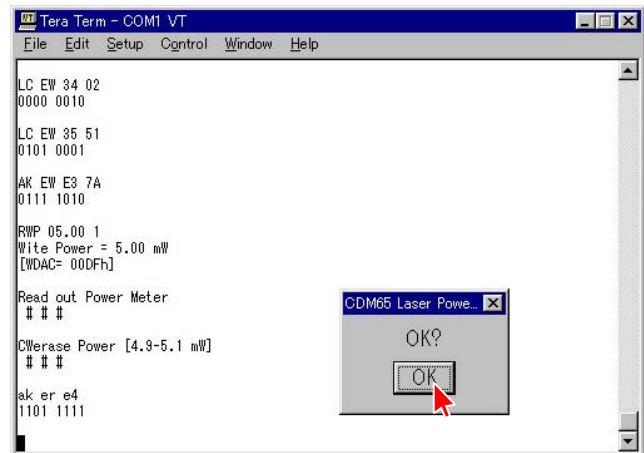

▲ Fig. 3-7

- 8) Check that the laser power meter reading satisfies the following requirement. When the laser power satisfies the required specification, press “OK”. (Fig. 3-8)

LEADER LPM-8001 : 9.2 to 9.6 mW

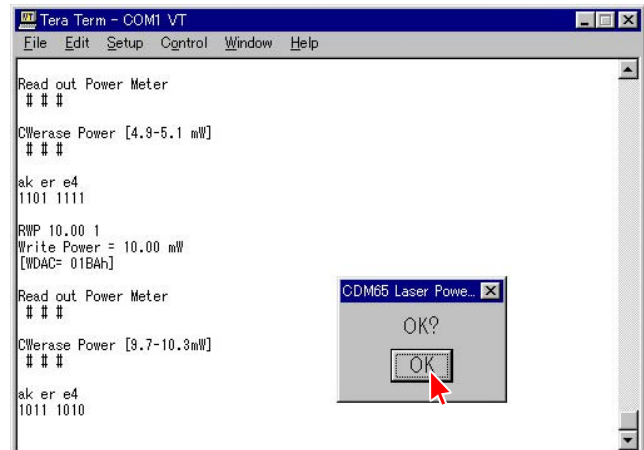

▲ Fig. 3-8

- 9) Check that the message “Power Check End” appears on display. (Fig. 3-9)

If the measurement result is outside the specification value, either perform Section 4. CDM65-RBD2 Electrical Adjustment, or locate the cause of the error by performing the Laser Deterioration Judgment.

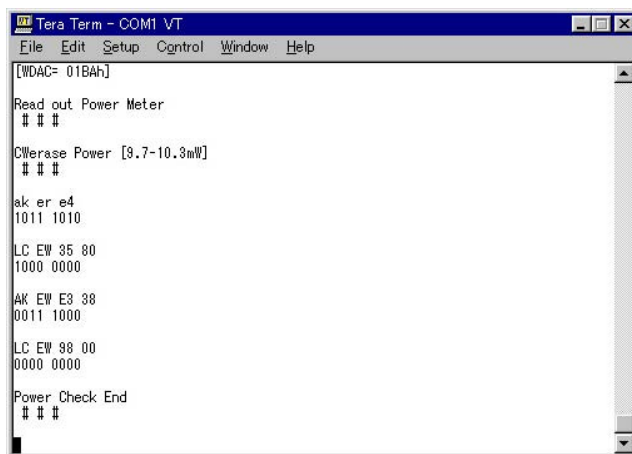

▲ Fig. 3-9

3-2. Laser Deterioration Judgment

- 1) Select the menu as follows. Control → Macro, and select 10vwdcC_S.ttl. Press “Open”. (Fig. 3-10, 3-11)

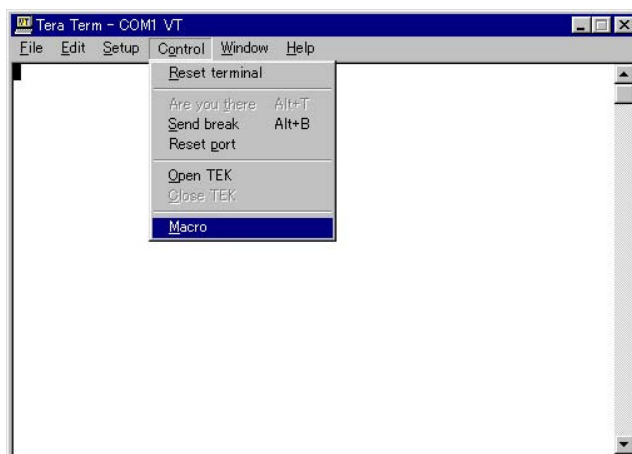

▲ Fig. 3-10

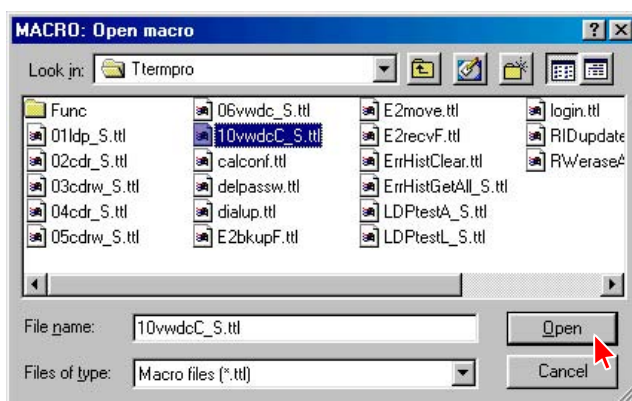

▲ Fig. 3-11

- 2) Press the “RESET” button (SW101) of the jig as prompted by the display.
- 3) When the message [OK] appears as shown in Fig. 3-12, press the “OK” button. When the laser unit KRM-220CAA (Op) is normal without deterioration of laser, the message [OK] appears. If the laser unit is deteriorated, the message [NG] appears. Then, replace the laser unit KRM-220CAA (Op).

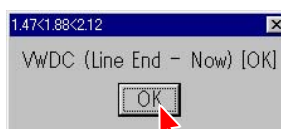

▲ Fig. 3-12

- 4) Check that the message “CDRW VWDC-CHECK completed!” appears. (Fig. 3-13)

NG Judgment Result Indication

When the present VWDC value of the laser unit KRM-220CAA (Op) does not satisfy the required specification, the message “VWDC (Line End - Now) [NG]” appears.

Measure: Check the peripheral of CN101.
Replace KRM-220CAA.

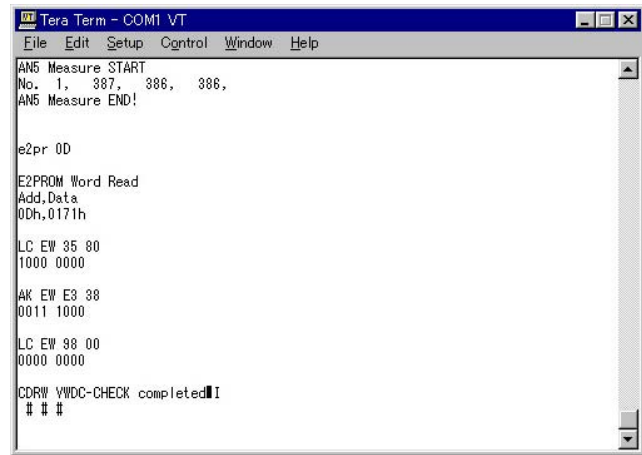

▲ Fig. 3-13

3-3. Use of Self Diagnosis Function-1 (In the case when result data of the past electrical adjustment, is not needed.)

Perform the self diagnosis as described below in the case when electrical adjustment is not performed yet, or when result data of the electrical adjustment in the past, is not needed and ready to be erased.)

- 1) Connect the CDM65-RBD2 (abbreviated as CDM65 hereafter) that is going to be repaired, the jig and a PC following the Connection Diagram as shown in section 1-1.
- 2) Turn on the power of the RCD-W500C in which the CDM65 is installed.
- 3) Start up the TeraTermPro that is installed in PC. Set the switch S510 on the jig to “CONTROL”.
- 4) Press the “RESET” button (SW101) of the jig. (Fig. 3-14)

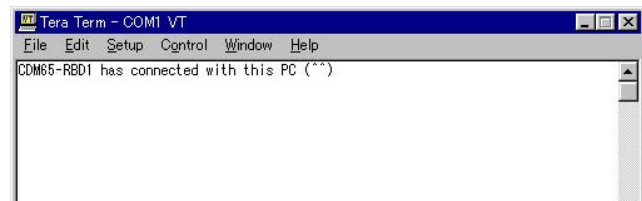

▲ Fig. 3-14

- 5) Type portchk [Enter] from keyboard of PC. (Fig. 3-15)

Note 5-1 : When the KRM-220CAA is connected, the spindle motor rotates at a high speed. If the message “H8/3064 Port Check END!” appears, press the “RESET” button and stop the spindle.

Note 5-2 : When the CDM65 (loading mechanism) is installed, ignore the message “PA (#93-100): NG”.

Confirm that “OK” is displayed in all items except for the cases as described above.

If “NG” is displayed in any item, it is assumed that the pin number of IC501 as shown in Fig. 3-15 is defective or its peripheral has abnormality. Perform the repair work again and repeat the self diagnosis. Repeat the repair work and self diagnosis until OK is displayed.

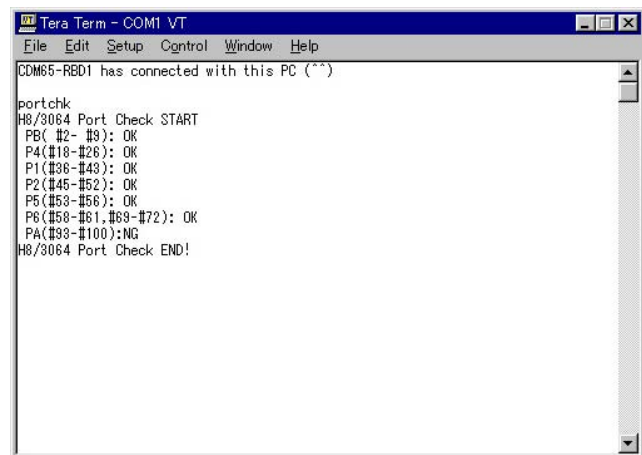

▲ Fig. 3-15

- 6) Type diagno [Enter] from keyboard of PC.

Note 6-1 : When the KRM-220CAA is connected, the spindle motor rotates at a high speed. If the message “Diagnosis END!” appears, press the “RESET” button and stop the spindle.

Note 6-2 : When the KRM-220CAA is connected (i.e. when the FFC for optical laser unit is connected to CN101 is connected), ignore the message “AK8567 (w/o OP) check: NG”.

Confirm that “OK” is displayed in all items except for the cases as described above.

If “NG” is displayed in any item, it is assumed that the point indicated by the item in Fig. 3-16 is defective or its peripheral has abnormality. Perform the repair work again and repeat the self diagnosis. Repeat the repair work and self diagnosis until “OK” is displayed.

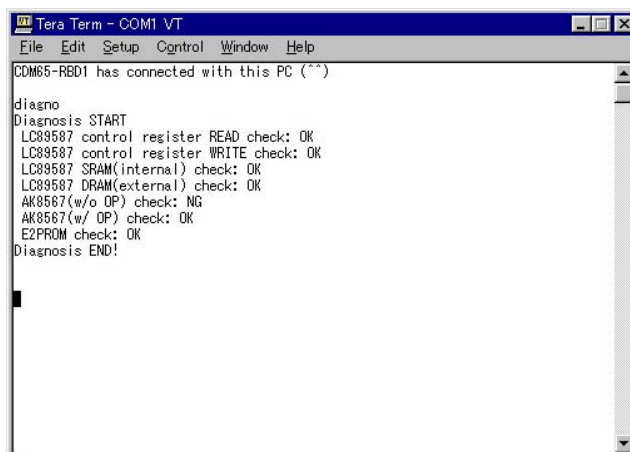

▲ Fig. 3-16

- 7) Perform the operation check.

3-4. Use of Self Diagnosis Function-2
(In the case when result data of the past electrical adjustment, should be left saved.)

Perform the self diagnosis as described below in the case when the faulty point could not be identified even after completion of the repair work that is defined as “The repair work in which electrical adjustment is not required” in section “2. Repair Works That Require Electrical Adjustment”.

- 1) Select the menu as follows. Control → Macro, and select E2bkupF.ttl.

Press “Open”. (Fig. 3-17, 3-18)

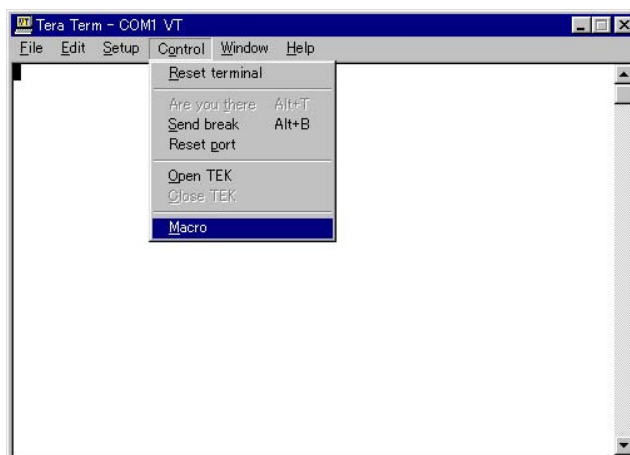

▲ Fig. 3-17

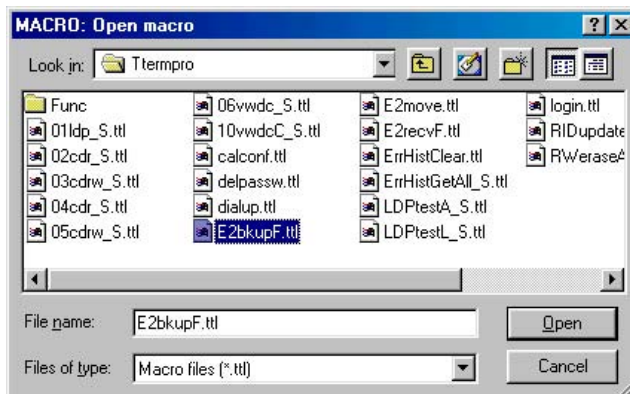

▲ Fig. 3-18

- 2) Type the filename in which result of electrical adjustment is going to be saved. Press “OK”. (Fig. 3-19)



▲ Fig. 3-19

- 3) Confirm that the message “completed!” appears. The EEPROM data is backed up. (Fig. 3-20)

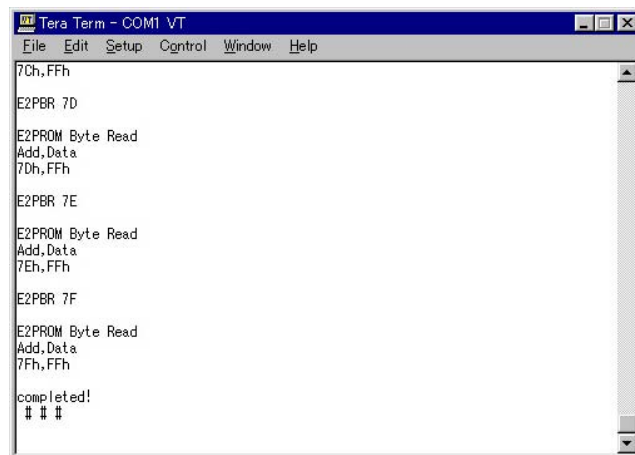

▲ Fig. 3-20

- 4) Perform step 1) through step 6) of section “3-3. Use of Self Diagnosis Function-1”.
- 5) Select the menu as follows. Control → Macro, and select E2recvF.ttl. Press “Open”.
- 6) Press the “RESET” button (SW101) of the jig as prompted by the display. (Fig. 3-21)

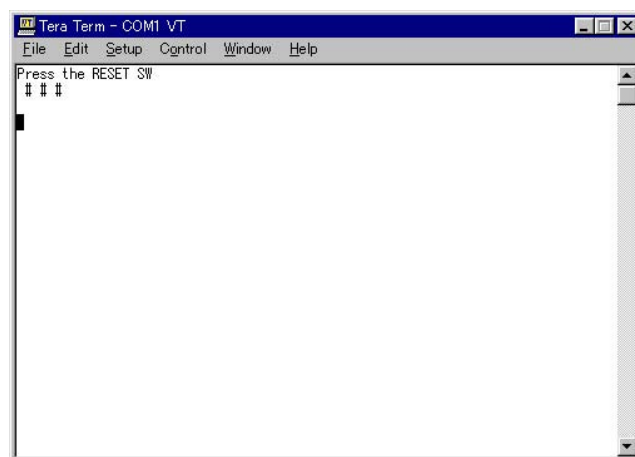

▲ Fig. 3-21

- 7) Type the filename in which result of electrical adjustment is saved. Press “OK”. (Fig. 3-22)



▲ Fig. 3-22

- 8) Confirm that the message “completed!” appears.
The EEPROM data is recovered. (Fig. 3-23)

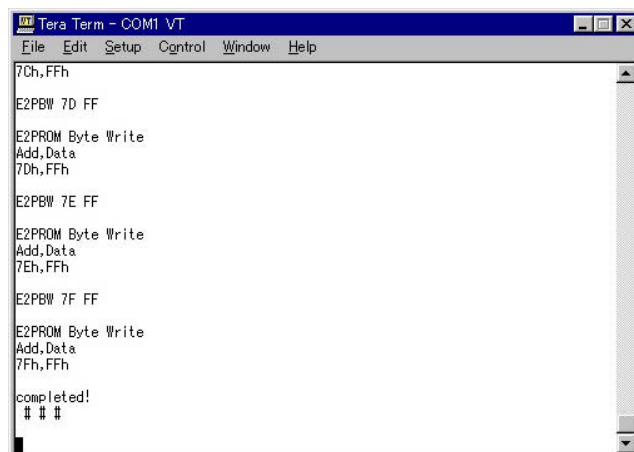

▲ Fig. 3-23

- 9) Perform the operation check.

3-5. Acquisition of Error History and Acquisition of Elapsed Operating Hours

Check if error has occurred or not by performing the following steps. If error has occurred, it is interpreted and saved in the specific directory. Check contents of the error by viewing the specific directory as described below.

- 1) Select the menu as follows. Control → Macro, and select ErrHistGetAll_S.ttl.
Press “Open”. (Fig. 3-24, 3-25)

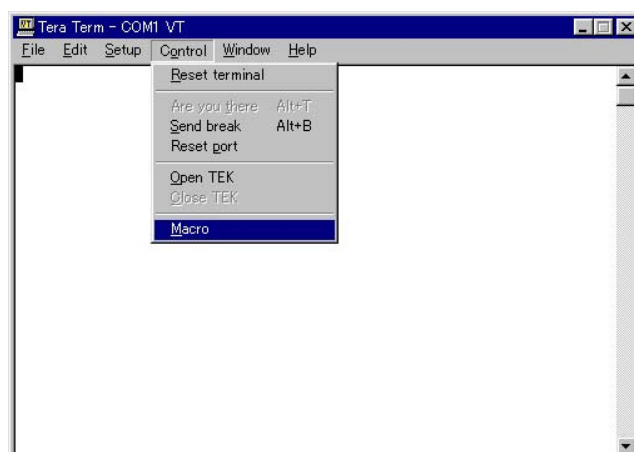

▲ Fig. 3-24

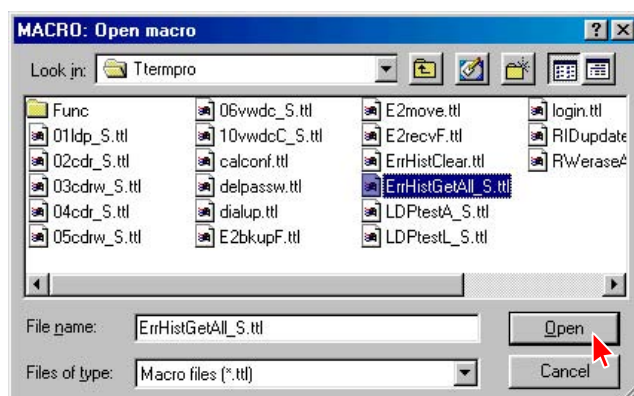

▲ Fig. 3-25

- 2) Press the “RESET” button (SW101) of the jig as prompted by the display.
- 3) When there is no error, the display as shown in Fig. 3-26 appears.

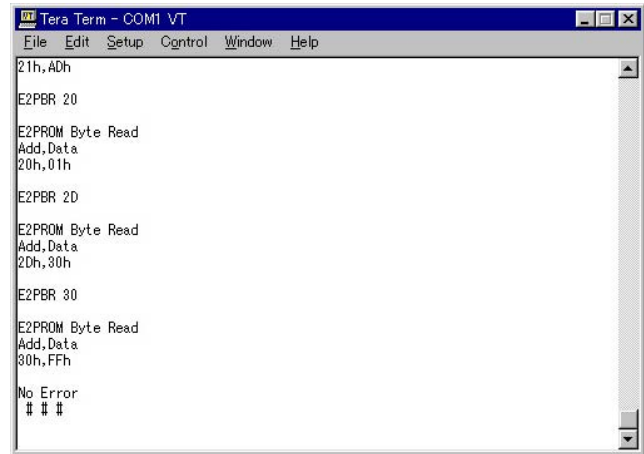

▲ Fig. 3-26

- 4) When error has occurred, the display as shown in Fig. 3-27 appears showing error history. Contents of the errors are displayed as shown in Fig. 3-28 after interpretation of the error log. Check the contents of the error by looking at the file “EEPROM_Errorlog.txt” in the TeraTermPro directory

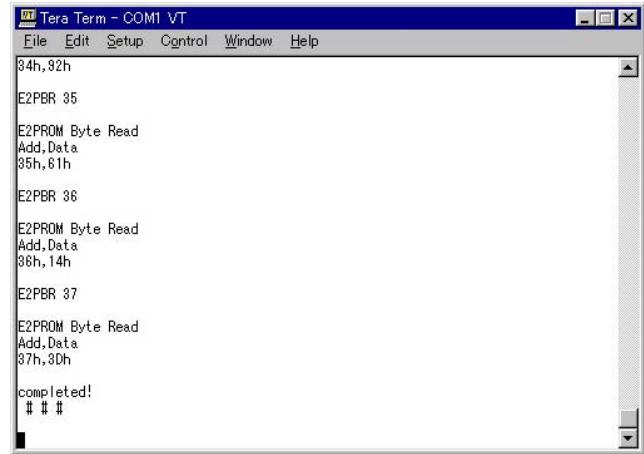

▲ Fig. 3-27

- 5) The elapsed operating hours is shown at the top of “EEPROM_Errorlog.txt” regardless of presence/absence of the error history. Check the elapsed operating hours from the display as shown in Fig. 3-28.

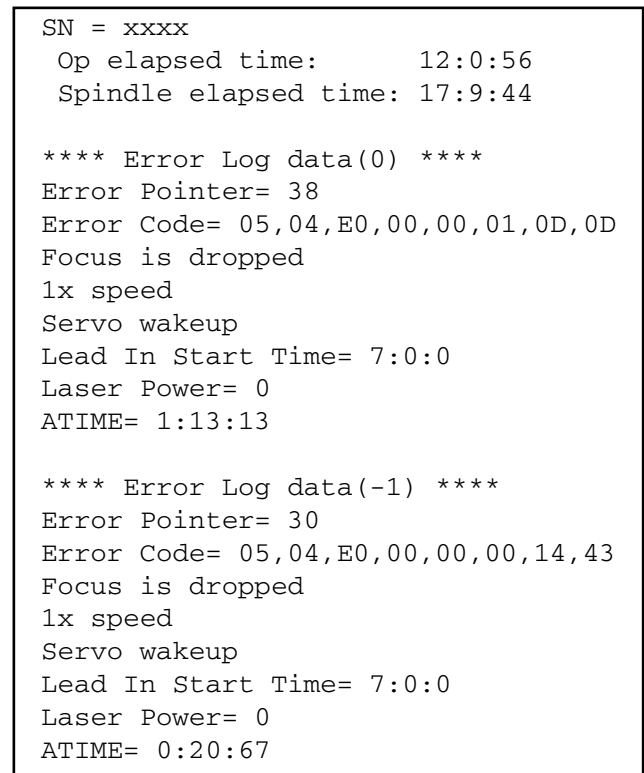

▲ Fig. 3-28 : Error log example

4. CDM65-RBD2 Electrical Adjustment

4-1. Laser Power Adjustment

- 1) Start up the TeraTermPro and set the switch S510 on the jig to “CONTROL”.
- 2) Select the menu as follows. Control → Macro, and select 01ldp_S.ttl.
Press “Open”. (Fig. 4-1)

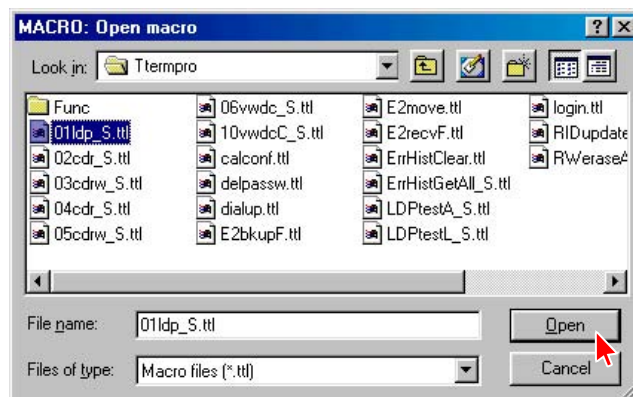

▲ Fig. 4-1

- 3) Press the “RESET” button (SW101) of the jig as prompted by the display.
- 4) Press the “RESET” button (SW101) of the jig again as prompted by the display.
- 5) When the display as shown in Fig. 4-2 appears, type the serial number (see Fig. 4-3) that is printed on the label attached to the RBD2. (This dialog appears only when the EEPROM IC502 is replaced.)

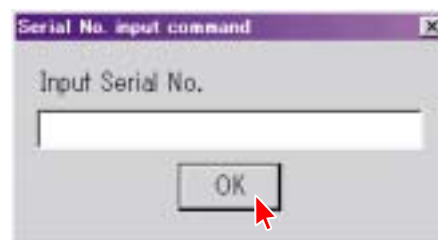

▲ Fig. 4-2



▲ Fig. 4-3

When the display as shown in Fig. 4-4 appears, press “No”.



▲ Fig. 4-4

When the display as shown in Fig. 4-5 appears after that, press “Yes”.

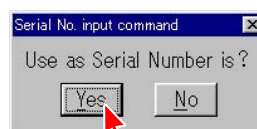

▲ Fig. 4-5

6) When the display as shown in Fig. 4-6 appears, place the probe of the laser power meter on top of the optical laser unit, and press “OK”. (See Fig. 3-3-a, page 31)



▲ Fig. 4-6

7) When the display as shown in Fig. 4-7 appears, set the Range of a laser power meter to “1 mW” and press “OK”.



▲ Fig. 4-7

8) Adjust the laser output power as follows.
The laser output power (i.e., laser power meter reading) should satisfy the specification shown below.

LEADER LPM-8001 : 0.81 +/- 0.05 mW (0.76 to 0.86 mW)

- * To increase the laser output power
Press [Yes] of the “Up?” dialog box.
- * To decrease the laser output power
Press [No] of the “Up?” dialog box and then press [Yes] of the “Down?” dialog box.

Repeat until the laser output power satisfies the specification. (Fig. 4-8, 4-9)

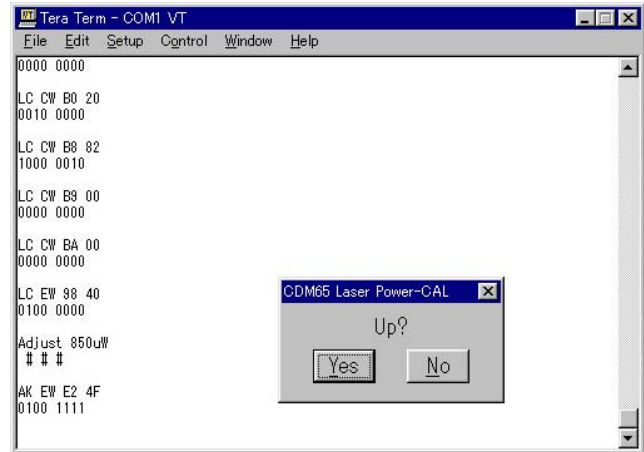

▲ Fig. 4-8

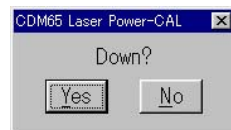

▲ Fig. 4-9

- * When the setting value is determined
Press [No] of the “Up?” dialog box
and then press [No] of the “Down?” dialog box
and press [Yes] of the “Save?” dialog box. (Fig. 4-10)



▲ Fig. 4-10

9) When the display shown in Fig. 4-11 appears, set the Range of a laser power meter to “10 mW” and press “OK”.



▲ Fig. 4-11

- 10) Adjust the laser output power as follows.
The laser output power (i.e., laser power meter reading) should satisfy the specification shown below.

LEADER LPM-8001 : 4.6 +/- 0.1 mW (4.5 to 4.7 mW)

- * To increase the laser output power
Press [Yes] of the “Up?” dialog box.
- * To decrease the laser output power
Press [No] of the “Up?” dialog box
and then press [Yes] of the “Down?” dialog box.

Repeat until the laser output power satisfies the specification.
(Fig. 4-12, 4-13)

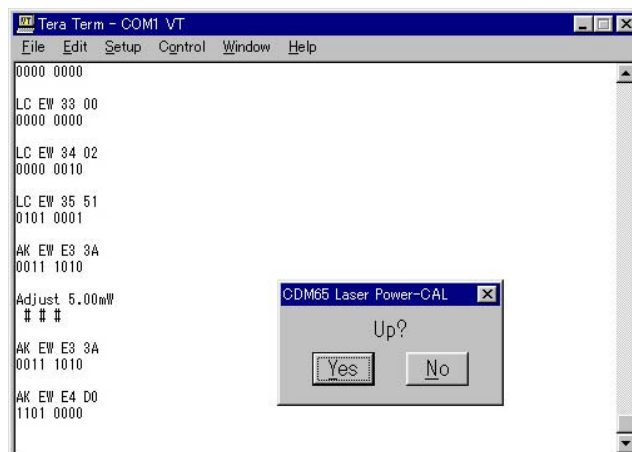

▲ Fig. 4-12



▲ Fig. 4-13



▲ Fig. 4-14

- * When the setting value is determined
Press [No] of the “Up?” dialog box
and then press [No] of the “Down?” dialog box
and press [Yes] of the “Save?” dialog box. (Fig. 4-14)

- 11) Adjust the laser output power as follows.
The laser output power (i.e., laser power meter reading) should satisfy the specification shown below.

LEADER LPM-8001 : 9.4 +/- 0.2 mW (9.2 to 9.6 mW)

- * To increase the laser output power
Press [Yes] of the “Up?” dialog box.
- * To decrease the laser output power
Press [No] of the “Up?” dialog box
and then press [Yes] of the “Down?” dialog box.

Repeat until the laser output power satisfies the specification.
(Fig. 4-15, 4-16)

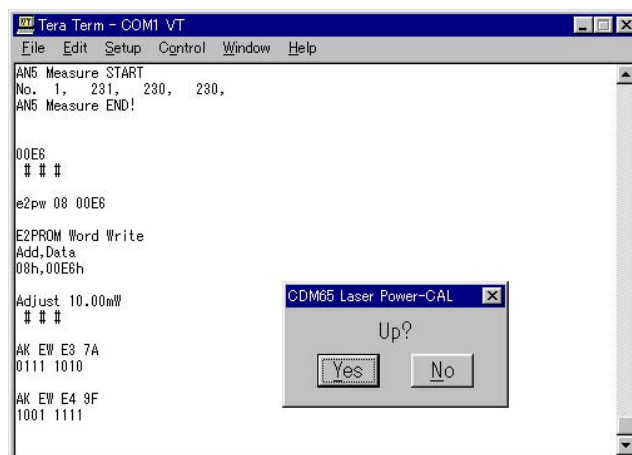

▲ Fig. 4-15



▲ Fig. 4-16



▲ Fig. 4-17

- * When the setting value is determined
Press [No] of the “Up?” dialog box
and then press [No] of the “Down?” dialog box
and press [Yes] of the “Save?” dialog box. (Fig. 4-17)

- When the display shown in Fig. 4-18 appears, remove probe of the laser power meter and press OK.



▲ Fig. 4-18

- Check that the message “Laser Power CAL completed!” appears. (Fig. 4-19)(The tray opens.)
NG Judgment Result Indication

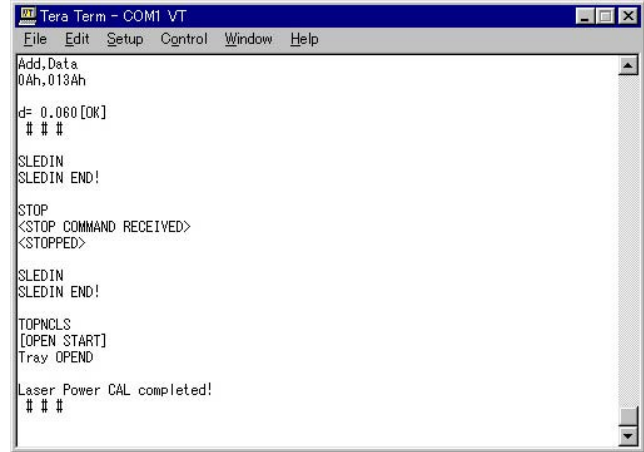

▲ Fig. 4-19

4-1-1. Sled Speed NG!

Contents : This message appears when the movement performance of sled is outside the specification.
Measure : Check if there is any abnormality in the sled drive circuit (IC171 peripheral) and the sled drive mechanism.

4-1-2. Power CAL NG!

Contents : This message appears when the laser emission intensity is outside the specification.
Measure : Check peripheral of CN101.
Replace KRM-220CAA.

4-2. CD/CD-R Playback Adjustment

- Select the menu as follows. Control → Macro, and select 02cdr_S.ttl. Press “Open”.
- Place the test CD disc PATD-012 on the tray as prompted by the display and press “OK”. (Fig. 4-20)(The tray closes.)



▲ Fig. 4-20

- Press the “RESET” button (SW101) of the jig as prompted by the display.
- As prompted by the message shown in Fig. 4-21, check that the waveform as shown in Fig. 4-22 appears on an oscilloscope.

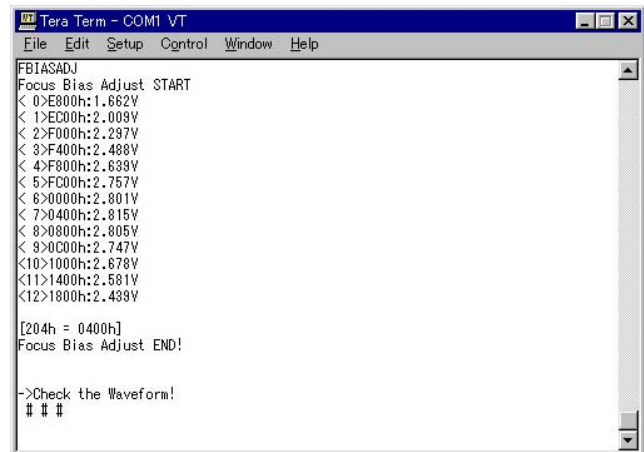

▲ Fig. 4-21

Note :The clear RF signal waveform means that the shape “◇” can be clearly distinguished at the center of the waveform.

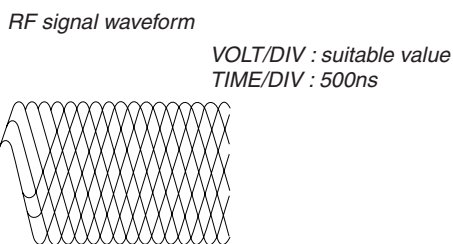

▲ Fig. 4-22

- 5) As prompted by the message shown in Fig. 4-24, check that the waveform as shown in Fig. 4-23 appears on an oscilloscope.

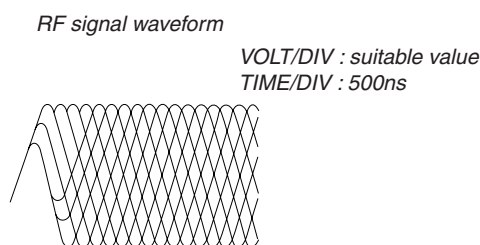

▲ Fig. 4-23

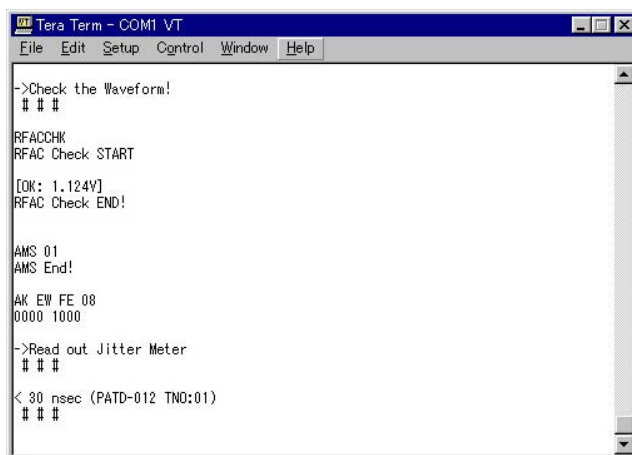

▲ Fig. 4-24

- 6) As prompted by the message shown in Fig. 4-26, check that the waveform as shown in Fig. 4-25 appears on an oscilloscope.

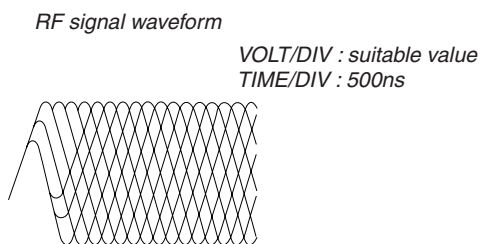

▲ Fig. 4-25

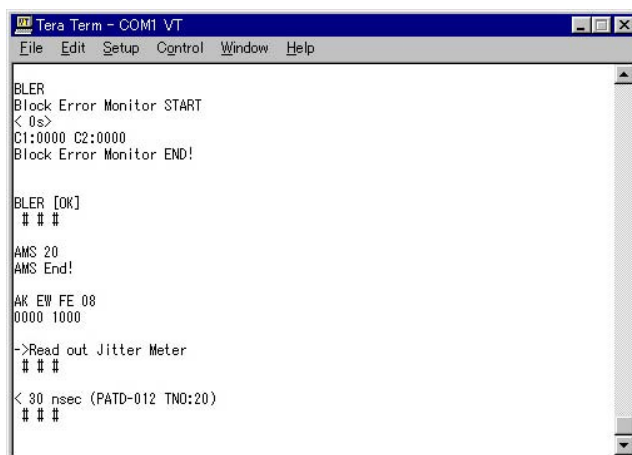

▲ Fig. 4-26

- 7) Check that the message “CDR PB-CAL completed!” appears. (The tray opens.)

NG Judgment Result Indication

4-2-1. Playback Measurement NG!

Contents : This message appears when the BLER (Block Error Rate) during playback is outside the specification.

Measure : Check if there is any abnormality in RBD2.

Replace KRM-220CAA.

4-3. CD-RW Playback Adjustment

- 1) Select the menu as follows. Control → Macro, and select 03cdr_S.ttl.
Press “Open”.
- 2) Place the test CD TCD-W091W on the tray as prompted by the display and press “OK”. (Fig. 4-27)(The tray closes.)

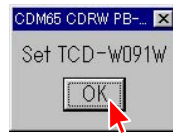

▲ Fig. 4-27

- 3) Press the “RESET” button (SW101) of the jig as prompted by the display.
- 4) As prompted by the message shown in Fig. 4-29, check that the waveform as shown in Fig. 4-28 appears on an oscilloscope.

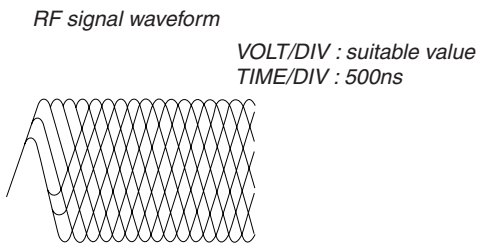

▲ Fig. 4-28

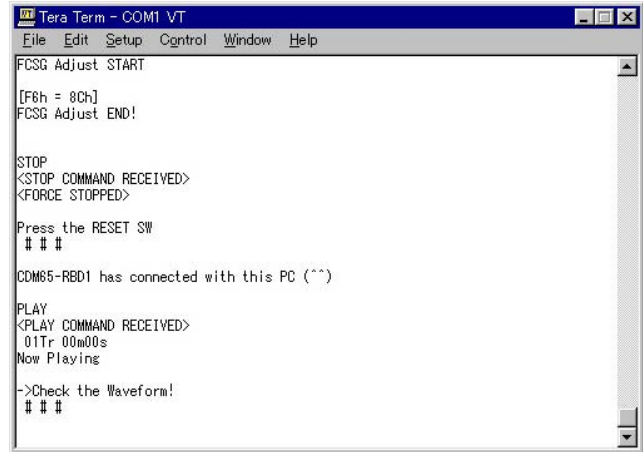

▲ Fig. 4-29

- 5) As prompted by the message shown in Fig. 4-31, check that the waveform as shown in Fig. 4-30 appears on an oscilloscope.

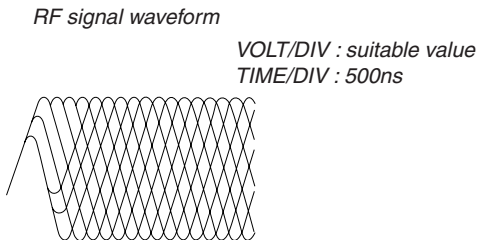

▲ Fig. 4-30

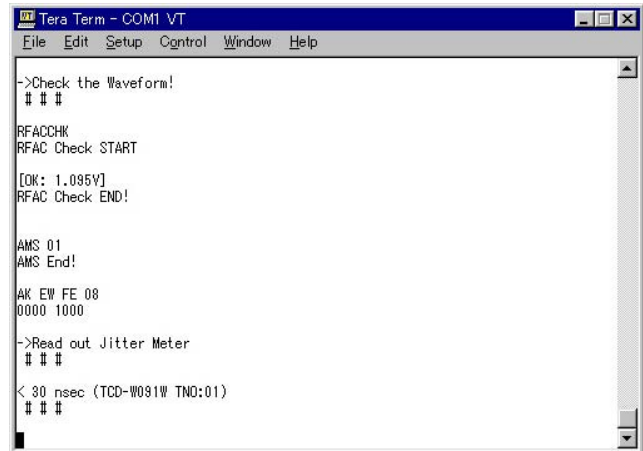

▲ Fig. 4-31

- 6) As prompted by the message shown in Fig. 4-33, check that the waveform as shown in Fig. 4-32 appears on an oscilloscope.

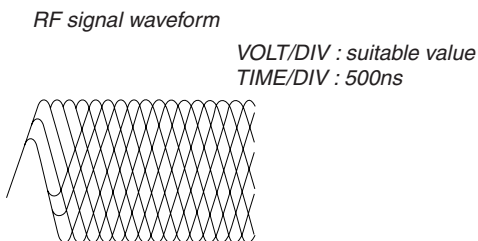

▲ Fig. 4-32

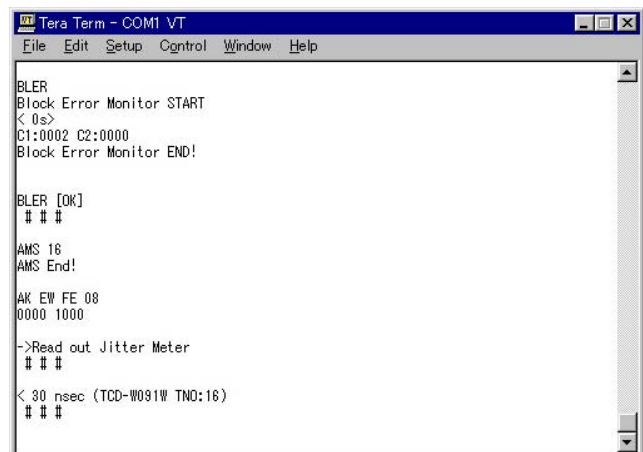

▲ Fig. 4-33

- 7) Check that the message “CDRW PB-CAL completed!” appears. (Fig. 4-34)(The tray opens.)

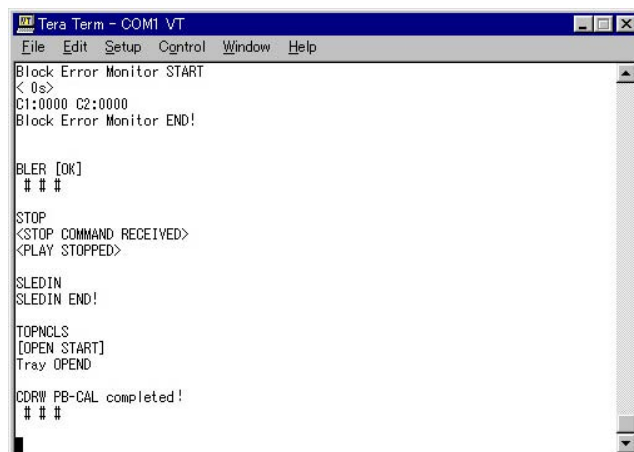

▲ Fig. 4-34

NG Judgment Result Indication

4-3-1. Playback Measurement NG!

Contents: This message appears when the BLER (Block Error Rate) during playback is outside the specification.

Measure : Check if there is any abnormality in RBD2.

Replace KRM-220CAA.

4-4. CD-R Recording Adjustment and Self Record/Playback Check

- 1) Select the menu as follows. Control → Macro, and select 04cdr_S.ttl. Press “Open”.
- 2) Place the test CD disc PATD-012 on the Deck A. Place the recording CD-R disc (see Note: 4-4-1) on the tray (Deck B) as prompted by the display and press “OK”. (Fig. 4-35) (The tray closes.)

Note : 4-4-1

The disc to be used in this step.

- * Use the CD-R disc CRM74 for audio, that is manufactured by Sony.
 - * The disc that is used by this step cannot be used for the general purposes and for the purpose of operation check of the RCD series equipment. The disc that is used for the general purposes or for the purpose of operation check of the RCD series equipment, cannot be used in this step.
 - * If the recording is interrupted by any reasons during the recording operation (i.e., the WRITE POWER ON LED of the jig is lighting), the disc cannot be used any more in the subsequent step. Use the un-used brand new disc and repeat this step from the very beginning again.
- 3) When the disc that is used in step 2) is the disc that has been used in the electrical adjustment in the past. Press “Yes”.

When the disc that is used in step 2) is a completely blank disc. Press “No”. (Fig. 4-36)

Note: The recording CD-R disc can be used only for the electrical adjustment. The recording CD-R disc must be controlled so that it must not be used for any other applications.



▲ Fig. 4-35



▲ Fig. 4-36

- 4) Press the  button of Deck A. After playback starts, press “OK”. (Fig. 4-37)

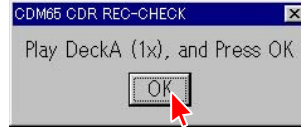

▲ Fig. 4-37

- 5) When the message as shown in Fig. 4-38 appears some seconds later, stop playback (1X) and select 4x of the test mode (refer to page 21, Play Speed Selection Mode (Deck A)) Playback Speed. Then press the  button of Deck A. After playback starts, press “OK”.

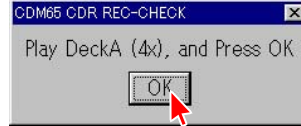

▲ Fig. 4-38

- 6) As prompted by the message shown in Fig. 4-40, check that the waveform as shown in Fig. 4-39 appears on an oscilloscope.

RF signal waveform

VOLT/DIV : suitable value
TIME/DIV : 500ns

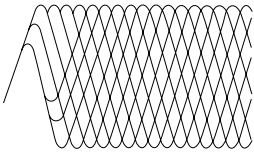

▲ Fig. 4-39

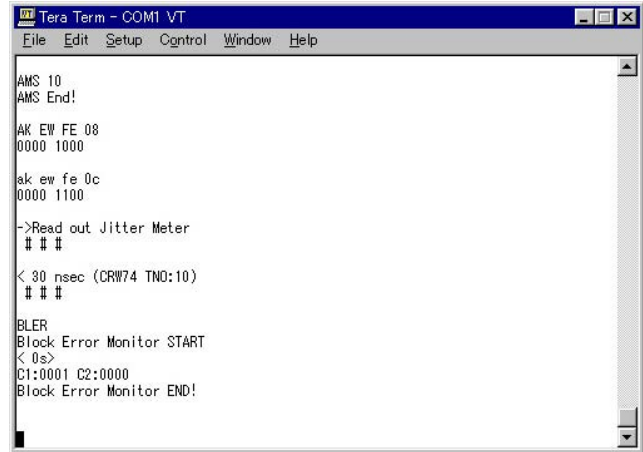

▲ Fig. 4-40

- 7) As prompted by the message shown in Fig. 4-42, check that the waveform as shown in Fig. 4-41 appears on an oscilloscope.

RF signal waveform

VOLT/DIV : suitable value
TIME/DIV : 500ns

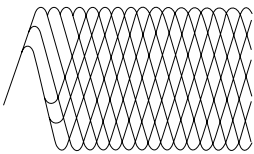

▲ Fig. 4-41

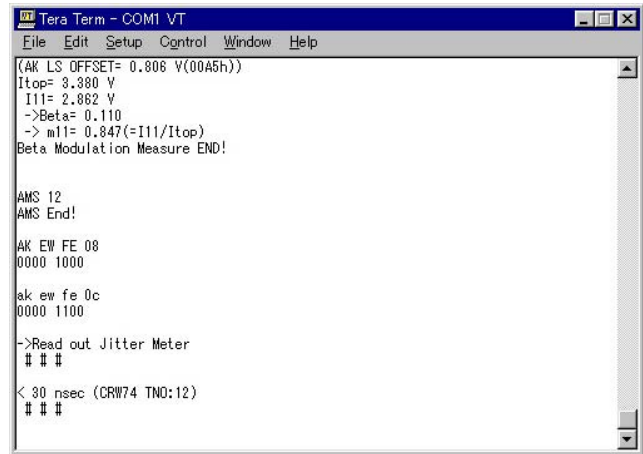

▲ Fig. 4-42

- 8) Check that the message “CDR REC-CHECK completed!” appears. (The tray opens.) Stop playback (4X) and exit from the test mode (Deck A). (refer to page 21.) NG Judgment Result Indication

4-4-1. CD-R Playback Measurement NG!

Contents : This message appears when the BLER (Block Error Rate) *Beta/m11 of the track that is recorded and played back, is outside the specification.

Measure : Check if there is any abnormality in RBD2.

Replace KRM-220CAA.

4-5. CD-RW Recording Adjustment and Self Record/Playback Check

- 1) Select the menu as follows. Control → Macro, and select 05cdrw_S.ttl.
Press “Open”.

- 2) Place the test CD disc PATD-012 on the Deck A. Place the recording CD-RW disc (see Note: 4-5-1) on the tray (Deck B) as prompted by the display and press “OK”. (Fig. 4-43)
(The tray closes.)

Note : 4-5-1

The disc to be used in this step.

- * Use the CD-RW disc CWM74 for audio, that is manufactured by Sony.
- * The disc that is used by this step cannot be used for the general purposes and for the purpose of operation check of the RCD series equipment as it is. The disc that is used for the general purposes or for the purpose of operation check of the RCD series equipment, cannot be used in this step.
When you want to use the CD-RW disc for other applications, erase the CD-RW disc.
- * If the recording is interrupted by any reasons during the recording operation (i.e., the WRITE POWER ON LED of the jig is lighting), the disc cannot be used any more in the subsequent step. In such a case, erase the CD-RW disc and repeat this step from the very beginning again.

- 3) When the disc that is used in step 2) is the disc that has been used in the electrical adjustment in the past. Press “Yes”.

When the disc that is used in step 2) is a completely blank disc. Press “No”. (Fig. 4-44)

Note: The recording CD-RW disc can be used only for the electrical adjustment. The recording CD-RW disc must be controlled so that it must not be used for any other applications.

- 4) Press the  button of Deck A. After playback starts, press “OK”. (Fig. 4-45)

- 5) When the message as shown in Fig. 4-46 appears some seconds later, stop playback (1X) and select 4x of the test mode (refer to page 21, Play Speed Selection Mode (Deck A)) Playback Speed. Then press the  button of Deck A. After playback starts, press “OK”.



▲ Fig. 4-43



▲ Fig. 4-44

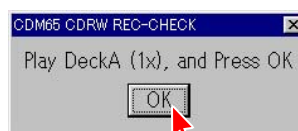

▲ Fig. 4-45

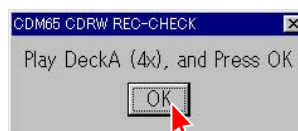

▲ Fig. 4-46

- 6) As prompted by the message shown in Fig. 4-48, check that the waveform as shown in Fig. 4-47 appears on an oscilloscope.

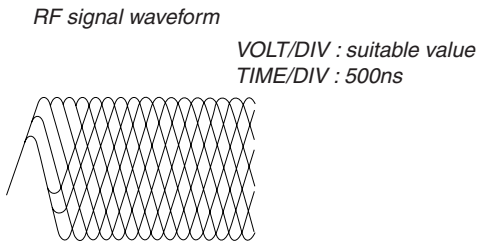

▲ Fig. 4-47

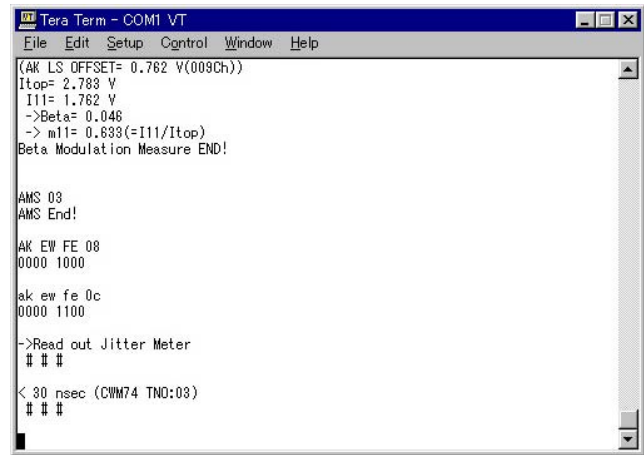

▲ Fig. 4-48

- 7) As prompted by the message shown on display, check that the waveform as shown in Fig. 4-49 appears on an oscilloscope.

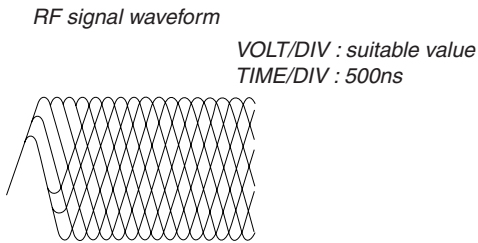

▲ Fig. 4-49

- 8) Check that the message “CDRW REC-CHECK completed!” appears. (Fig. 4-50)(The tray opens.)
Stop playback (4X) and exit from the test mode (Deck A).
(refer to page 21.)

NG Judgment Result Indication

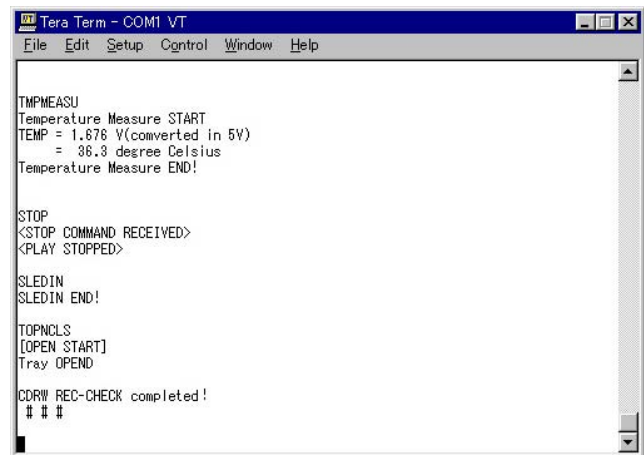

▲ Fig. 4-50

4-5-1. CD-RW Playback Measurement NG!

Contents : This message appears when the BLER (Block Error Rate) *Beta/m11 of the track that is recorded and played back, is outside the specification.

Measure : Check if there is any abnormality in RBD2.
Replace KRM-220CAA.

4-6. VWDC Check

- 1) Select the menu as follows. Control → Macro, and select 06vwdc_S.ttl. Press “Open”.
- 2) As prompted by the message shown in Fig. 4-51, remove the disc from the tray and press “OK”.



▲ Fig. 4-51

- 3) Because this step saves the result of electrical adjustment in a file, there can be a case that the dialog as shown in Fig. 4-52 appears.

When you want to overwrite Press “Yes”.
When you want to create a new file Press “No”.

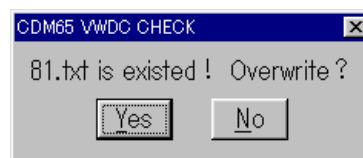

▲ Fig. 4-52

- 4) Check that the message “CDRW VWDC-CHECK completed!” appears. (Fig. 4-53)

NG Judgment Result Indication

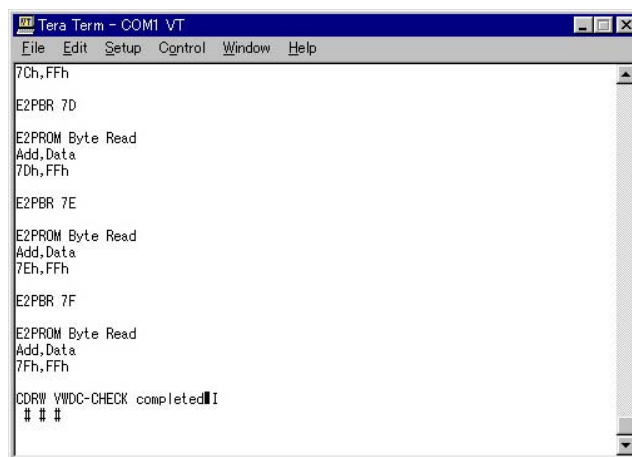

▲ Fig. 4-53

4-6-1. EEPROM Write NG!

Contents : This message appears when writing data into EEPROM fails.

Measure : When the steps of 011dp_S.ttl through 05cdrw_S.ttl have no problem and the error occurs only in this step, it is assumed that an error has occurred momentarily in the interface between PC and CDM65. Therefore, repeat execution of 06vwdc_S.ttl again.

4-6-2. VWDC judge [Line Top - End] [NG]

Contents : This message appears when the VWDC value is outside the specification.

Measure : It is assumed that the optical laser unit has deteriorated. If this error occurs after the KRM-220CAA is replaced, the adjustment error in the step of 011dp_S.ttl is assumed. Therefore, repeat execution of steps of 011dp_S.ttl through 05cdrw_S.ttl again. In the cases other than above, check if the laser power adjustment is correctly performed or not, using LDPtestL_S.ttl.

4-7. NG Message List

Message	Cause
Tray OPEN NG!	The tray has not opened within the specified time.
Tray Close NG!	The tray has not closed within the specified time.
SLEDIN NG!	The sled has not moved toward inner circumference within the specified time.
SLEDOUT NG!	The sled has not moved toward outer circumference within the specified time.
RIDR NG!	The RID information could not be read out within the specified time.
SNread (1) NG!	The SN (1) information could not be read out within the specified time.
SNread (2) NG!	The SN (2) information could not be read out within the specified time.
SNread (3) NG!	The SN (3) information could not be read out within the specified time.
FBIASADJ NG!	The Focus Bias Adjustment has not completed within the specified time.
FEOSADJ NG!	The FE Offset Adjustment has not completed within the specified time.
FESAMPADJ NG!	The FE Amplitude Adjustment has not completed within the specified time.
RFACCHK NG!	The RFAC amplitude is abnormal or the adjustment has not completed within the specified time.
RPINWADJ1 NG!	The Read Power (during Write1) Adjustment has not completed within the specified time.
RPINWADJ2 NG!	The Read Power (during Write2) Adjustment has not completed within the specified time.
SERVOSET NG!	The Servo Setting has not completed within the specified time.
TSa NG!	The ATIME Search has not completed within the specified time.
PLAYSW NG!	The Play operation has not started within the specified time.
STOP NG!	The Stop operation has not completed within the specified time.
AMS NG!	The AMS operation has not completed within the specified time.
ATIPPLAY NG!	The ATIP Play operation has not started within the specified time.
END TNO get NG!	The record-end track information could not be obtained within the specified time.
LEADOUT info.get NG!	The record-end time information could not be obtained within the specified time.
Invalid EndTrackNo./LeadoutTime !	The illegal record-end track and its time information were obtained.
Use the Blank disc	The disc exceeding the allowable limit is used.
DIR unlock!	The equipment could not be synchronized with the signal connected to DIN2.
RWP NG!	The CD-R Write Power setting has not completed within the specified time.
RWWP NG!	The CD-RW Write Power setting has not completed within the specified time.
REC NG!	The record operation could not be started within the specified time.

5. Operation Check

5-1. Erasing the Error History

- 1) Select the menu as follows. Control → Macro, and select ErrHistClear.ttl.
Press “Open”. (Fig. 5-1, 5-2)



▲ Fig. 5-1

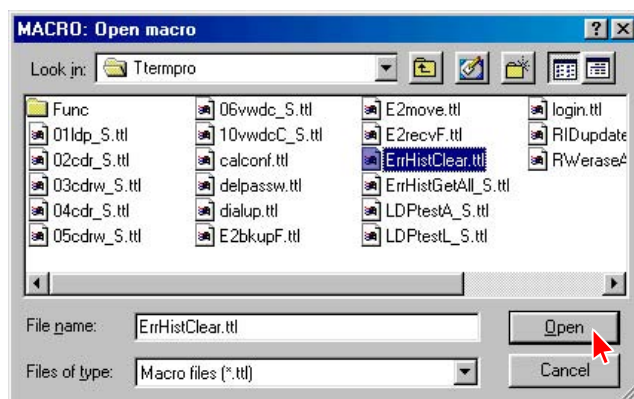

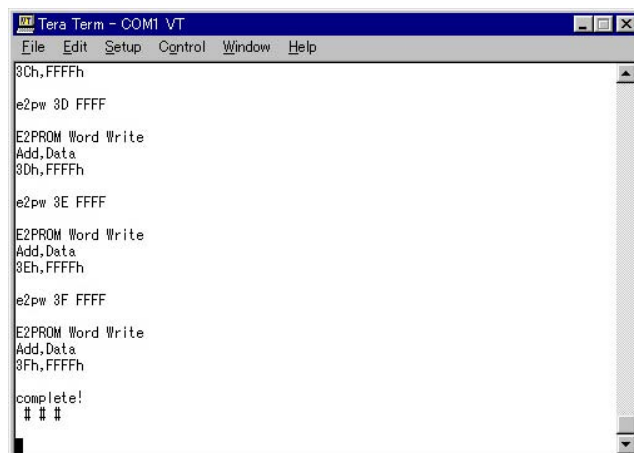

▲ Fig. 5-2

- 2) Press the “RESET” button (SW101) of the jig as prompted by the display.
- 3) Check that the message “completed!” appears. (Fig. 5-3)



▲ Fig. 5-3

5-2. Playback Check using TCD-W032W

- 1) Install the CDM65 in the equipment and install the TCD-W032W in Deck B.
- 2) Rotate the  (Deck B) knob to select the track 16. Start playback by pressing the same knob or by pressing the  (Deck B) button.
- 3) Perform playback for 10 seconds or more and confirm that there is no abnormality such as sound skipping and others.

Supplementary Information

Method to Erase the CD-RW Disc

- * Erase it in the following procedure, to reuse the CD-RW disc to electrical adjustment, or to use a disc other than blank.
- * Be sure to erase it in the following procedure, to use the disc used for electrical adjustment for other uses.

- 1) Select the menu as follows. Control → Macro, and select RWeraseA.ttl.
Press “Open”. (Fig. A-1, A-2)



▲ Fig. A-1

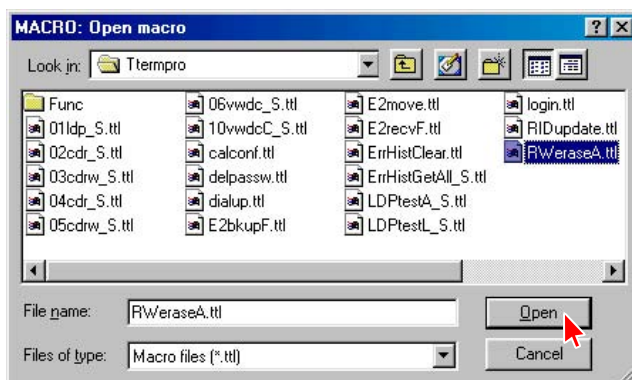

▲ Fig. A-2

- 2) Press the “RESET” button (SW101) of the jig as prompted by the display. (Fig. A-3)

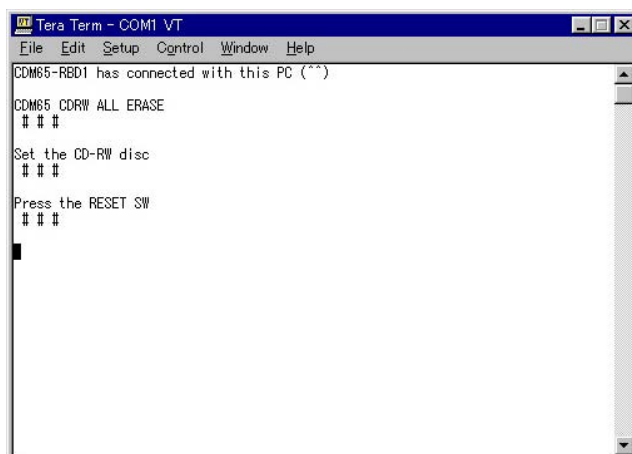

▲ Fig. A-3

- 3) Check that the time display as shown by the arrow mark in Fig. A-4 is updated after a while.

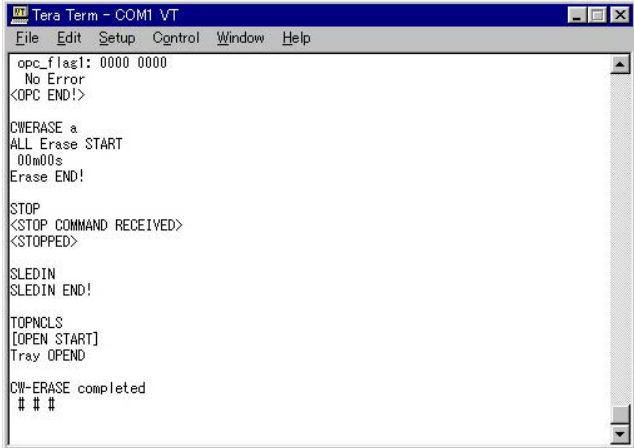

```
opc_flag1: 0000 0000
No Error
<OPC END!>

CWERASE a
ALL Erase START
00m00s
Erase END!

STOP
<STOP COMMAND RECEIVED>
<STOPPED>

SLEDIN
SLEDIN END!

TOPNCLS
[OPEN START]
Tray OPEND

CW-ERASE completed
# # #
```

▲ Fig. A-4

- 4) When update of time display is stopped and rotation of spindle is stopped, press the STOP button (SW501) of the Jig, and then press the EJECT button (SW508) of the jig to remove the disc.

SECTION 6 DIAGRAMS

THIS NOTE IS COMMON FOR PRINTED WIRING BOARDS AND SCHEMATIC DIAGRAMS.
(In addition to this necessary note is printed in each block.)

For schematic diagrams.

Note:

- All capacitors are in μF unless otherwise noted. p : pF. 50 WV or less are not indicated except for electrolytics and tantalums.
- All resistors are in Ω and $\frac{1}{4}\text{W}$ or less unless otherwise specified.
- Δ : internal component.
- \square : panel designation.

Note:

The components identified by mark Δ or dotted line with mark Δ are critical for safety. Replace only with part number specified.

Note:

Les composants identifiés par une marque Δ sont critiques pour la sécurité. Ne les remplacer que par une pièce portant le numéro spécifié.

• — : B+ Line.

• - - - : B- Line.

• : adjustment for repair.

• Voltages and waveforms are dc with respect to ground under no-signal (detuned) conditions.
No mark : STOP

• Voltages are taken with a VOM (Input impedance $10\text{M}\Omega$).
Voltage variations may be noted due to normal production tolerances.

• Waveforms are taken with a oscilloscope.
Voltage variations may be noted due to normal production tolerances.

• Circled numbers refer to waveforms.

• **Signal path.**

⇨ : CD PLAY

⇨⇨ : CD-R PLAY (ANALOG OUT)

⇨⇨⇨ : CD-R REC (ANALOG IN)

⇨⇨⇨⇨ : CD-R REC (CD)

For printed wiring boards.

Note:

• : parts extracted from the component side.

• : parts extracted from the conductor side.

• \circ : Through hole.

• : Pattern from the side which enables seeing.

(The other layers' patterns are not indicated.)

• **Indication of transistor**

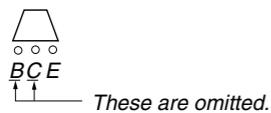
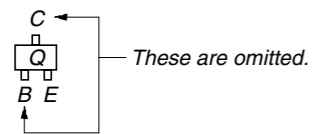

Caution:

Pattern face side: Parts on the pattern face side seen from the pattern face are indicated.

Parts face side: Parts on the parts face side seen from the parts face are indicated.

• **Waveform**

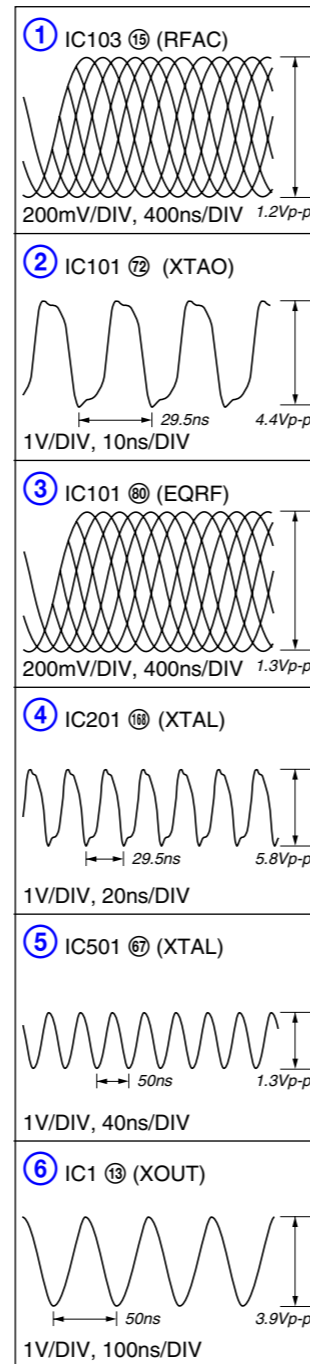

• **Circuit Board Location**

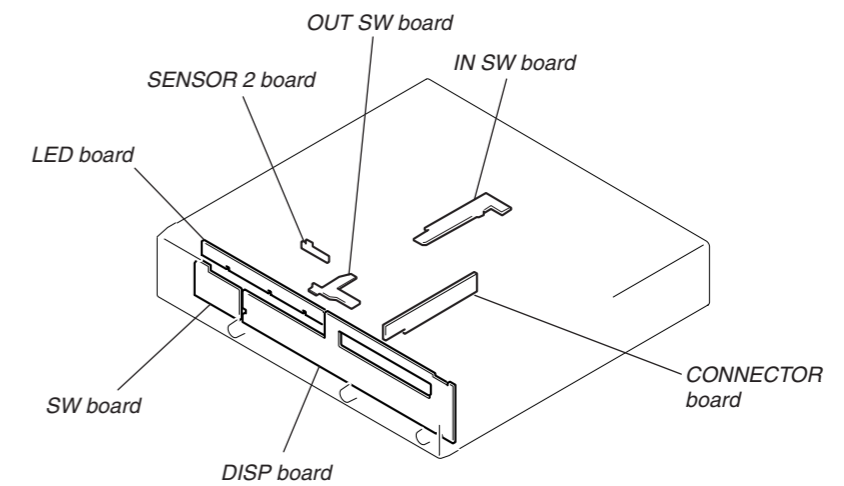
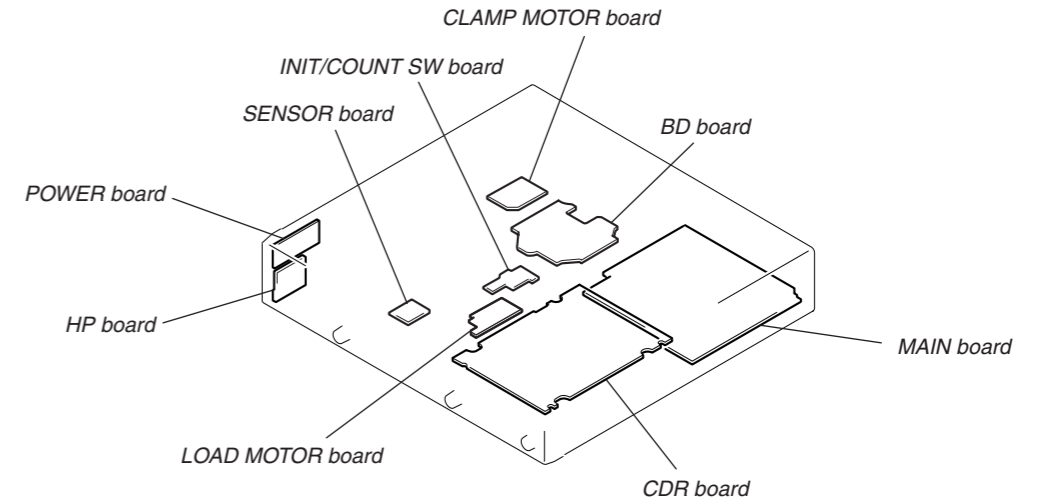

RCD-W500C

6-1. Block Diagrams – CD-R Section –

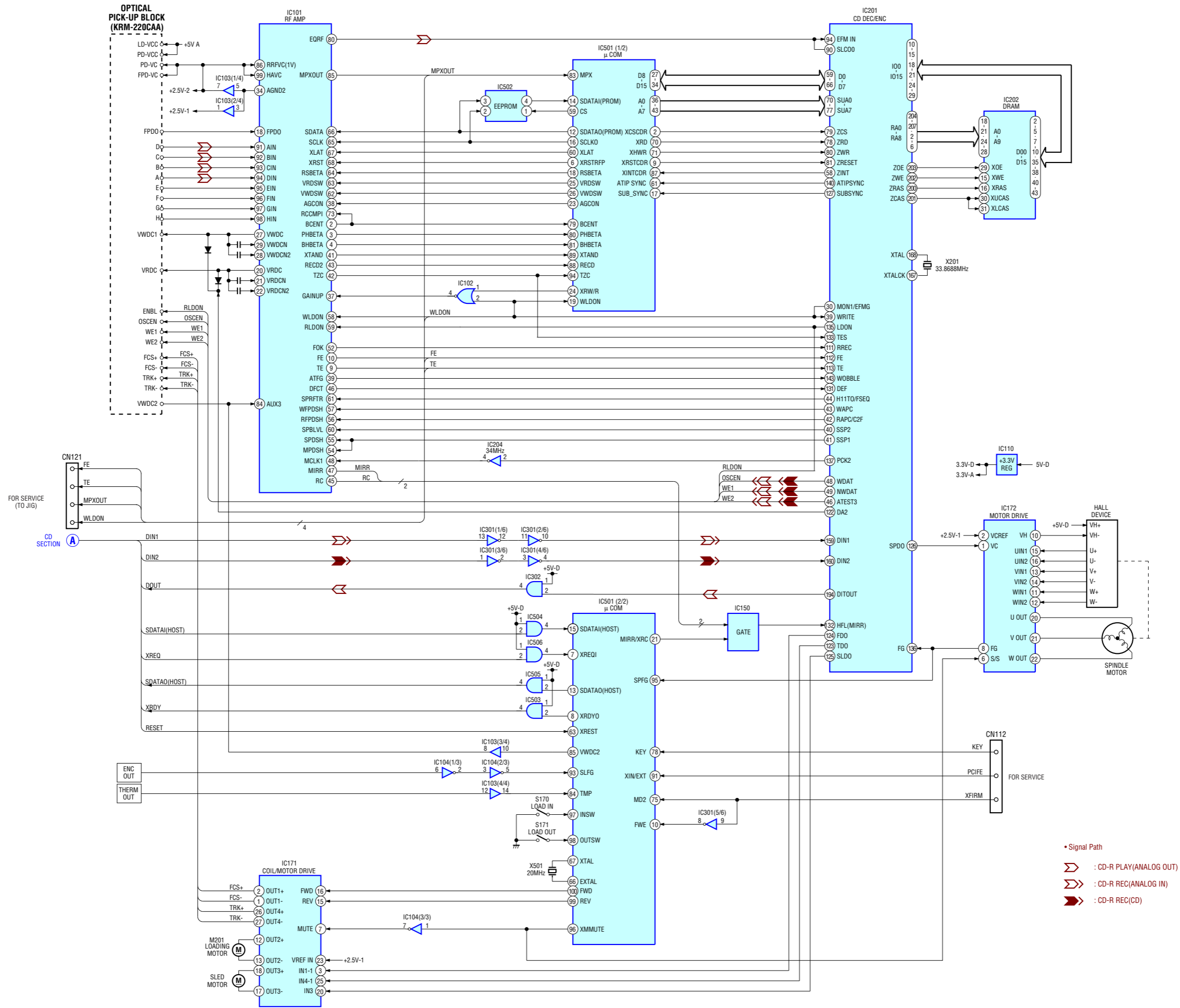

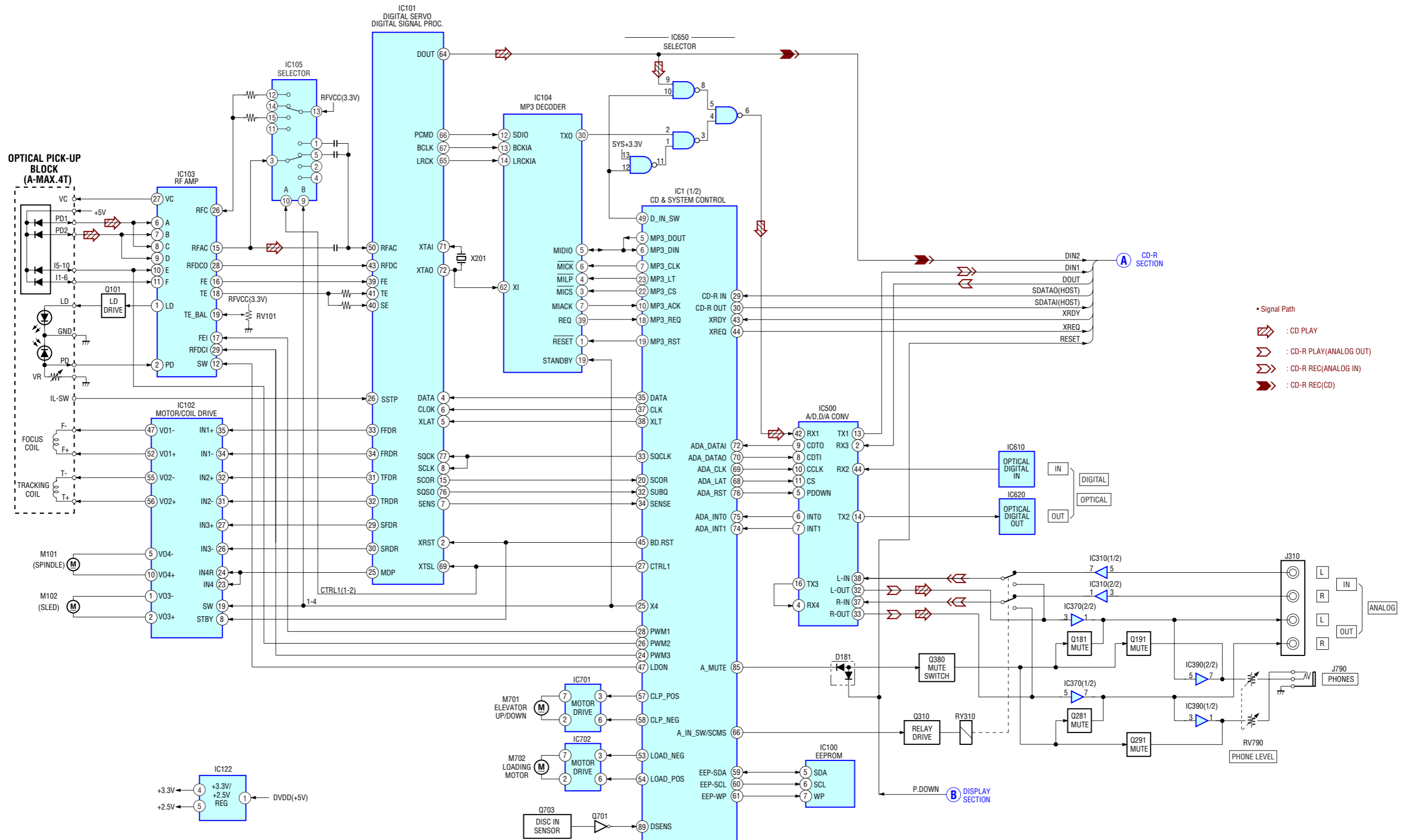

- CD Section -

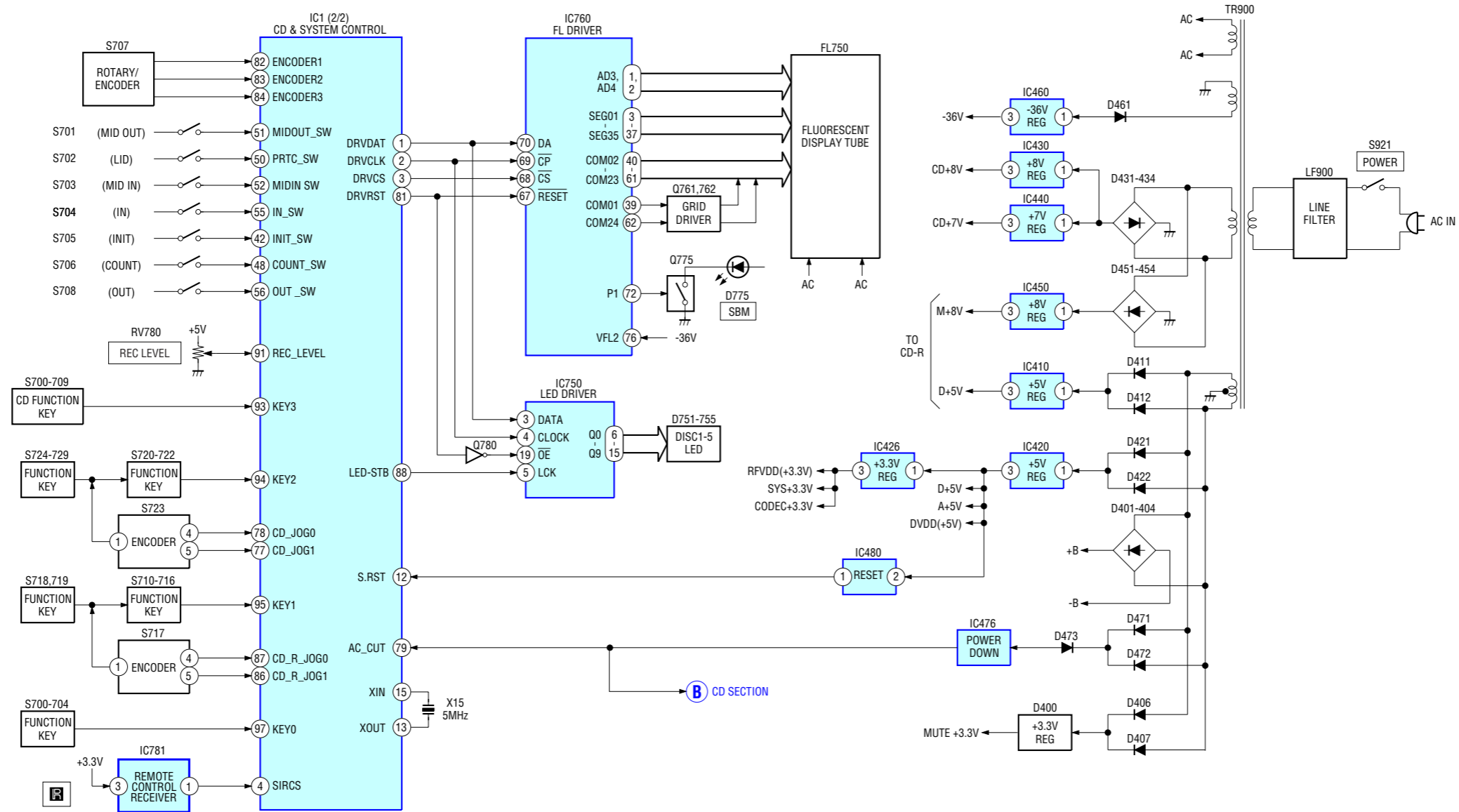

RCD-W500C

- POWER/DISPLAY Section -



6-2. Printed Wiring Boards – BD Section – • See page 55 for Circuit Boards Location. •  : Uses unleaded solder.

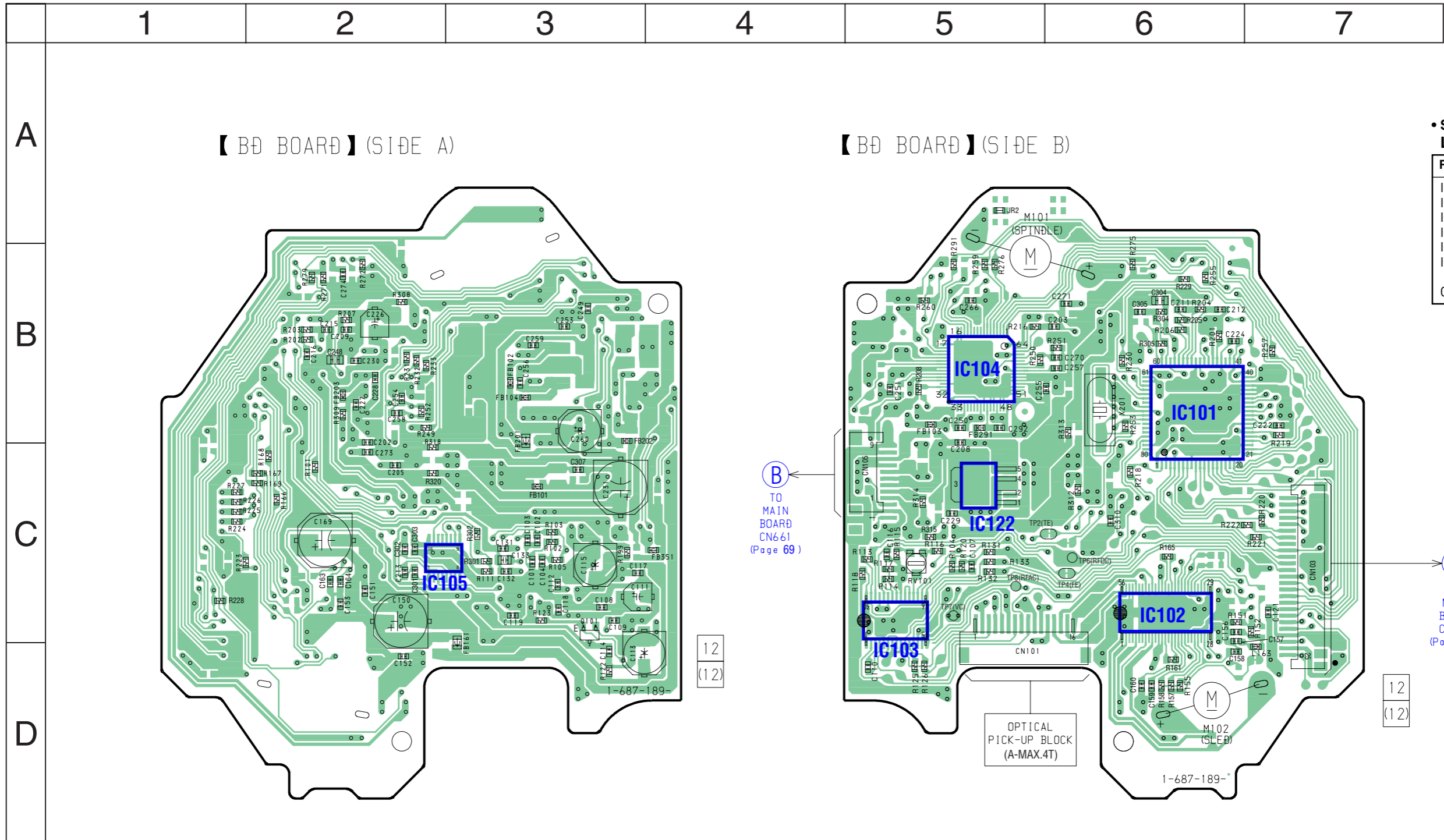

• Semiconductor Location

Ref. No.	Location
IC101	B-6
IC102	C-6
IC103	D-5
IC104	B-5
IC105	C-2
IC122	C-5
Q101	C-3

12
(12)

12
(12)

B
TO
MAIN
BOARD
CN661
(Page 69)

A
TO
MAIN
BOARD
CN 660
(Page 69)

OPTICAL
PICK-UP BLOCK
(A-MAX.4T)

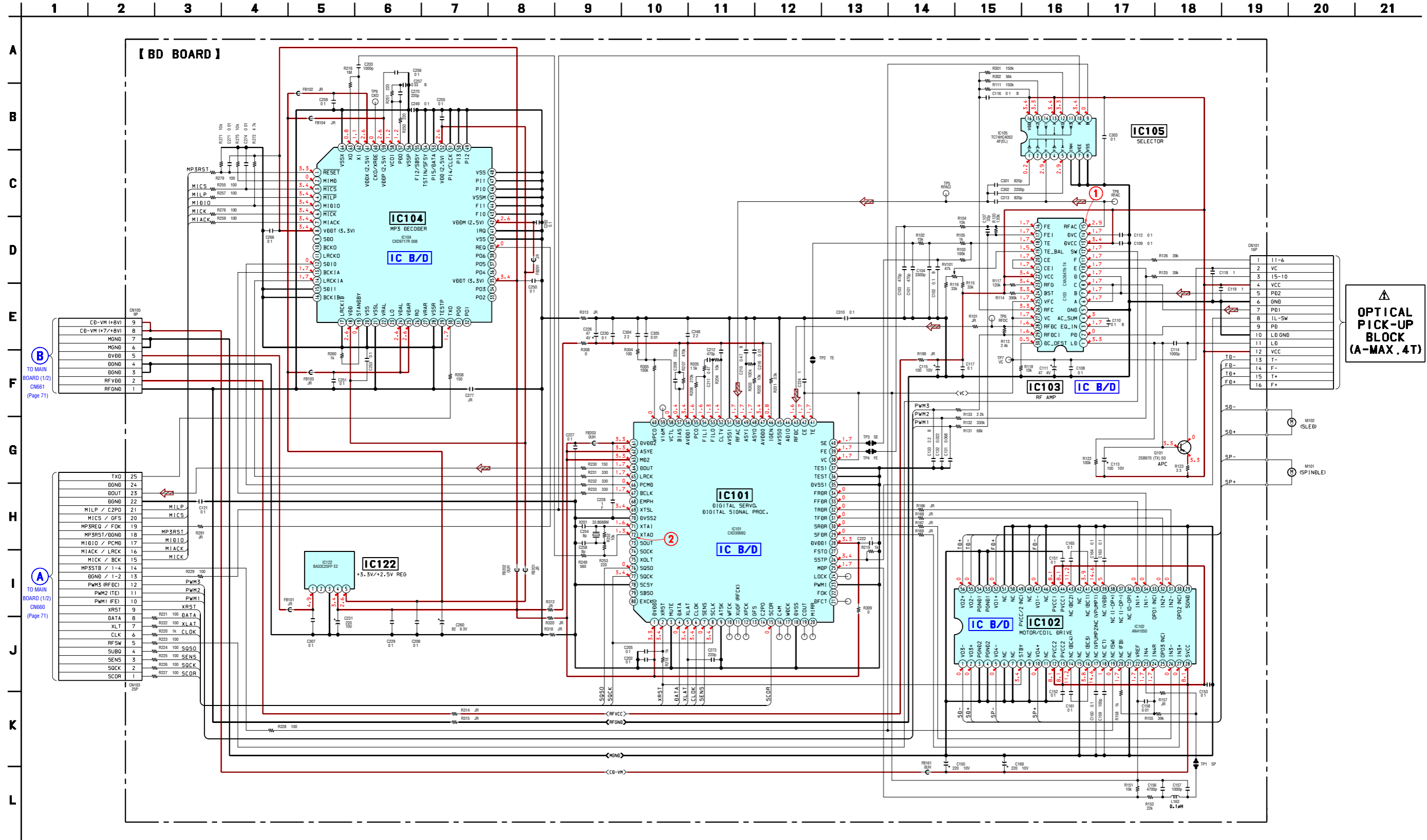

6-4. Printed Wiring Boards – SENSER/MOTOR/SW Section – • See page 55 for Circuit Boards Location.

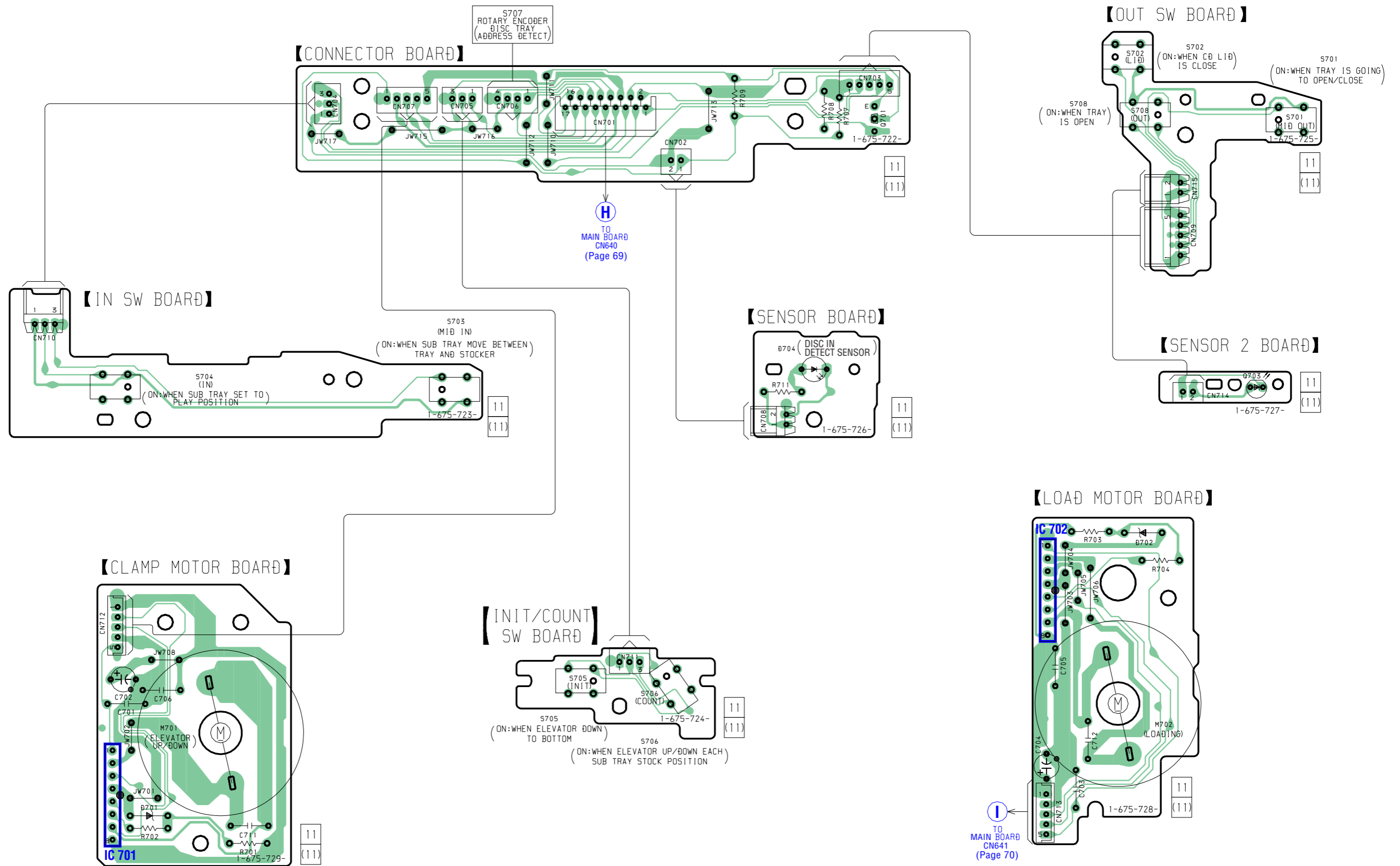

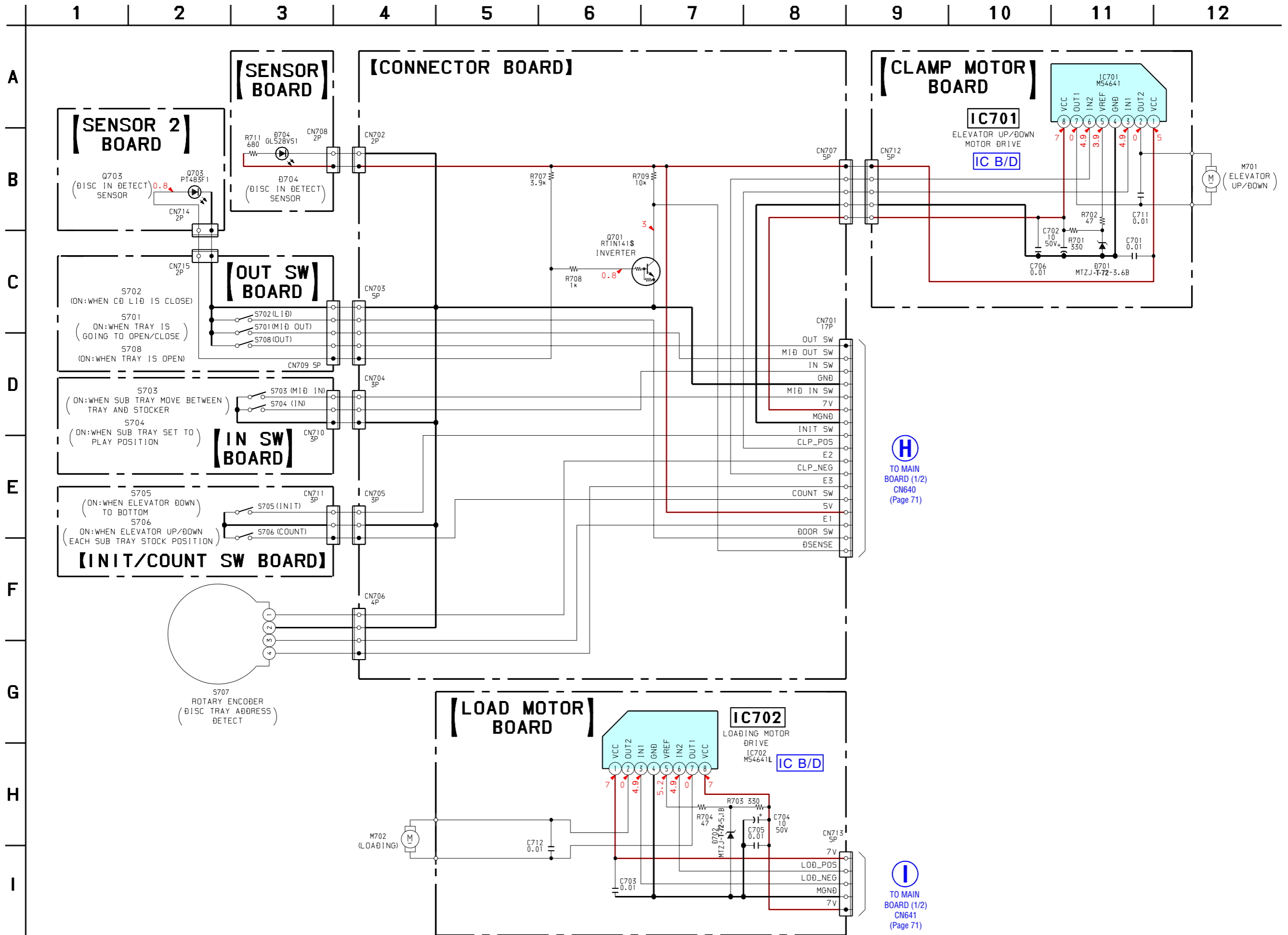

6-6. Printed Wiring Boards – CD-R Section (Side A) – • See page 55 for Circuit Boards Location. •  : Uses unleaded solder.

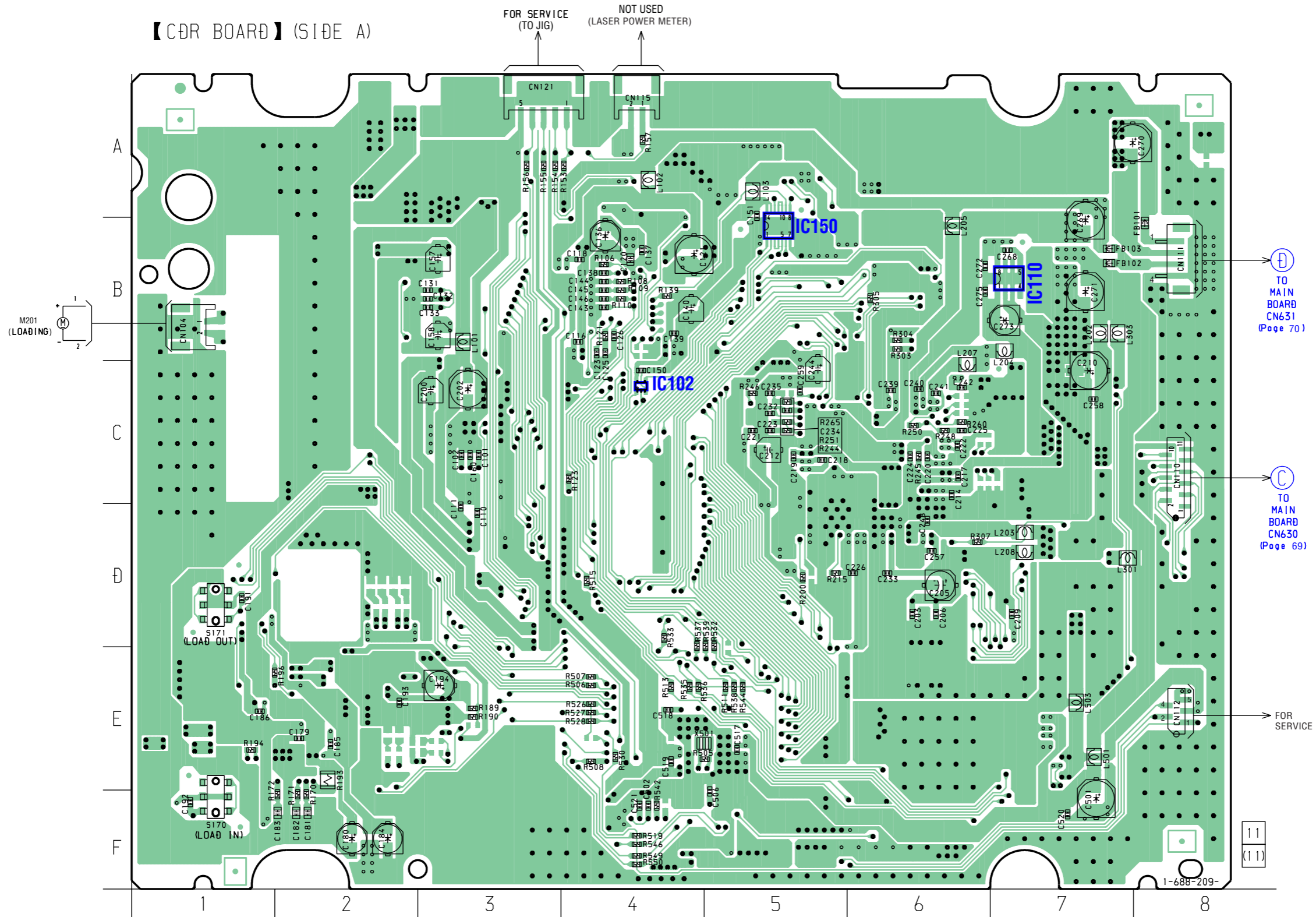

• Semiconductor Location

Ref. No.	Location
IC102	C-4
IC110	B-7
IC150	B-5

ⓓ TO MAIN BOARD CN631 (Page 70)

ⓐ TO MAIN BOARD CN630 (Page 69)

→ FOR SERVICE

11
(11)

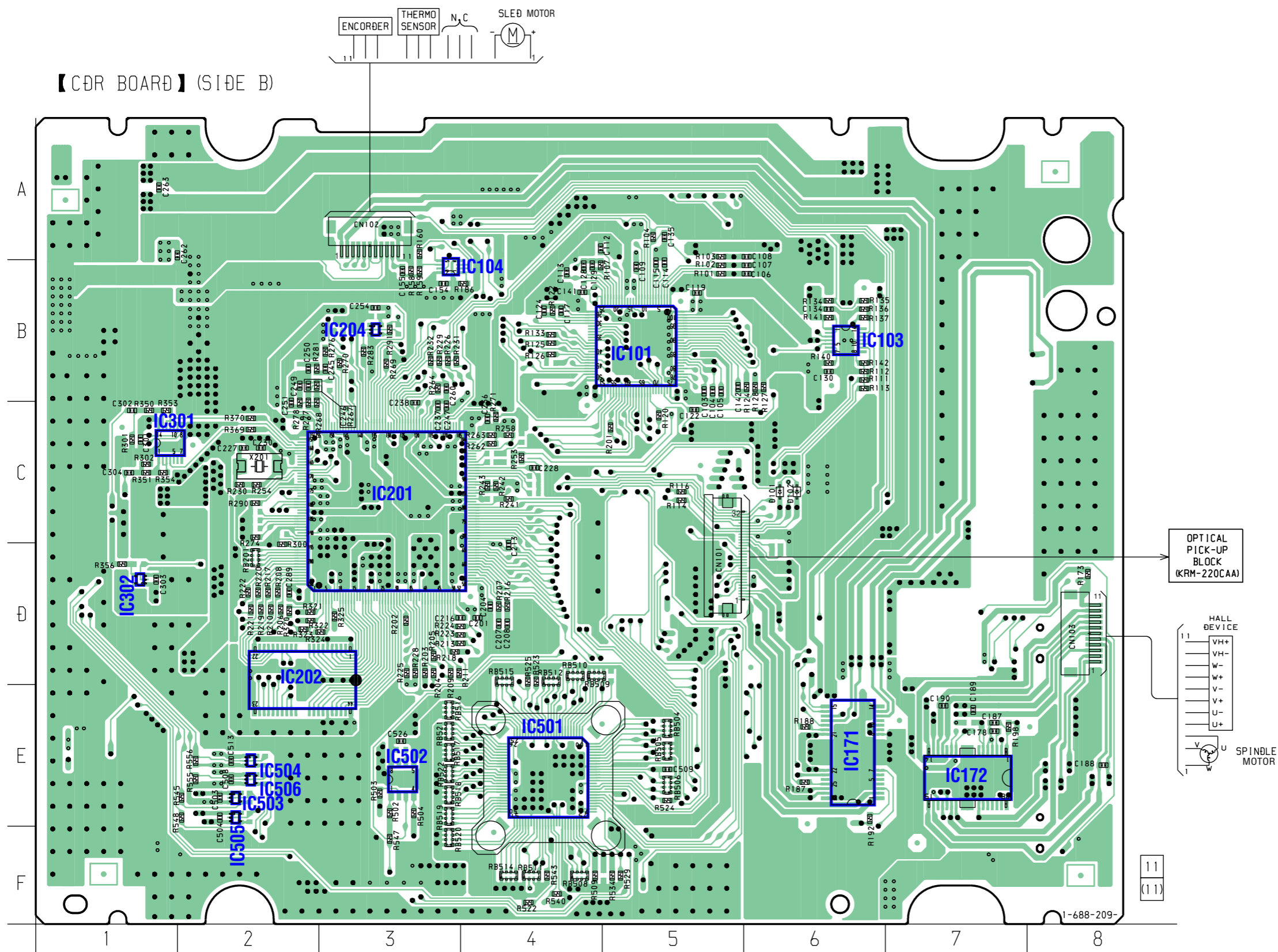

• Semiconductor Location

Ref. No.	Location
D101	C-6
D102	C-6
IC101	B-5
IC103	B-7
IC104	B-4
IC171	E-6
IC172	E-7
IC201	C-3
IC202	D-2
IC204	B-3
IC301	C-2
IC302	D-1
IC501	E-4
IC502	E-3
IC503	E-2
IC504	E-2
IC505	F-2
IC506	E-2

6-8. Schematic Diagrams – CD-R Section (1/4) – • See page 55 for Waveform. • See page 86 for IC Pin Function.

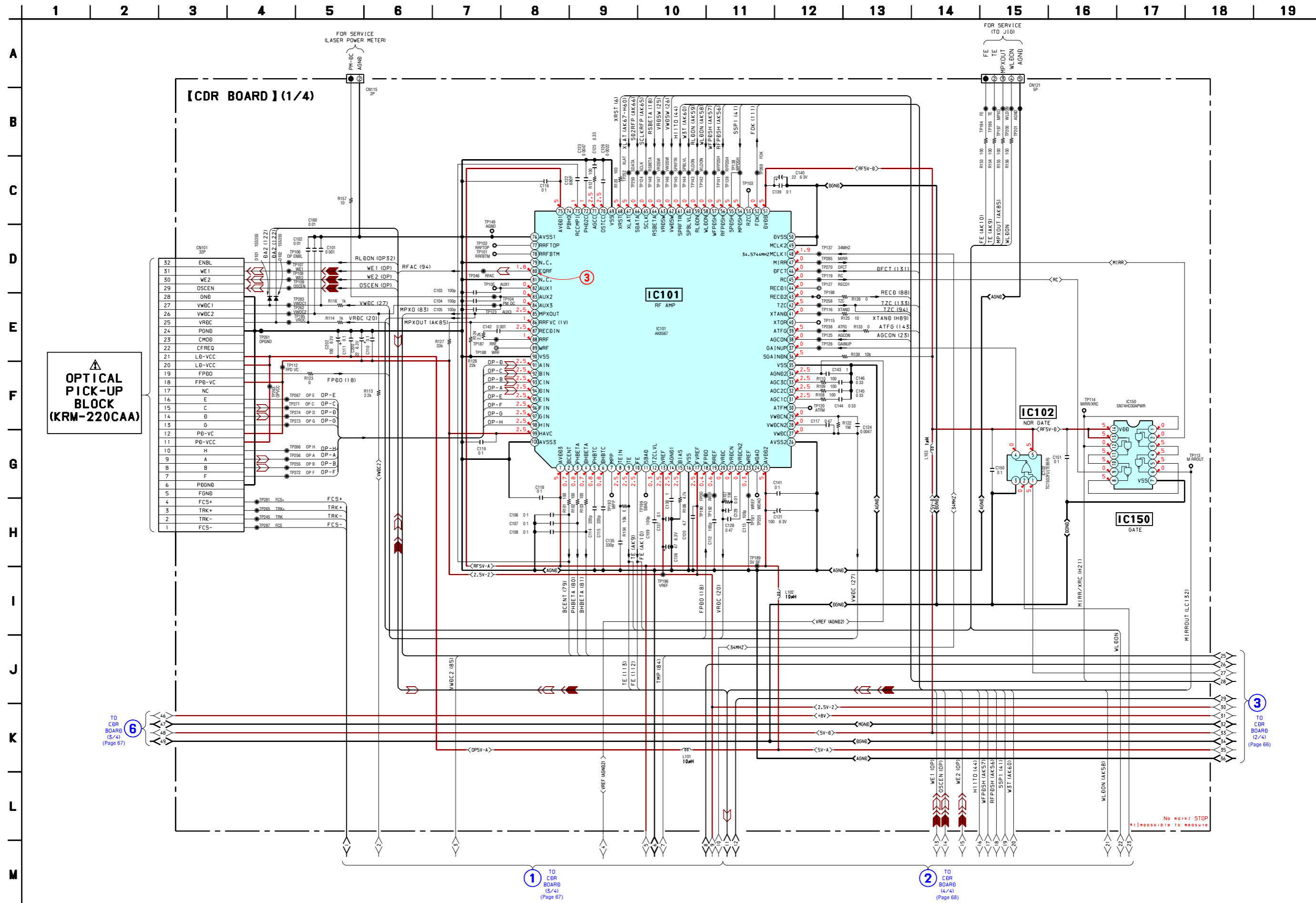

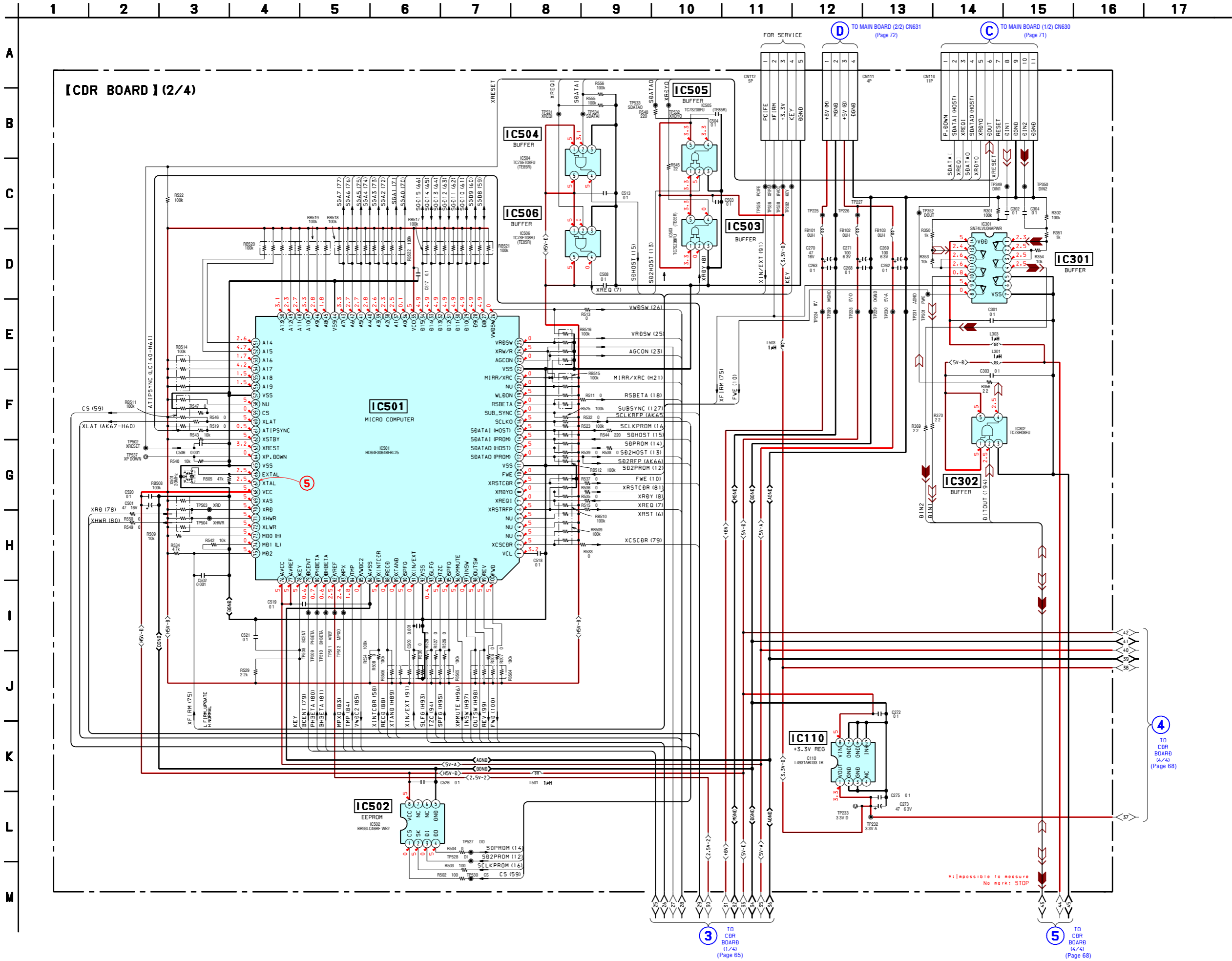

6-10. Schematic Diagrams – CD-R Section (3/4) – • See page 80 and 81 for IC Block Diagrams.

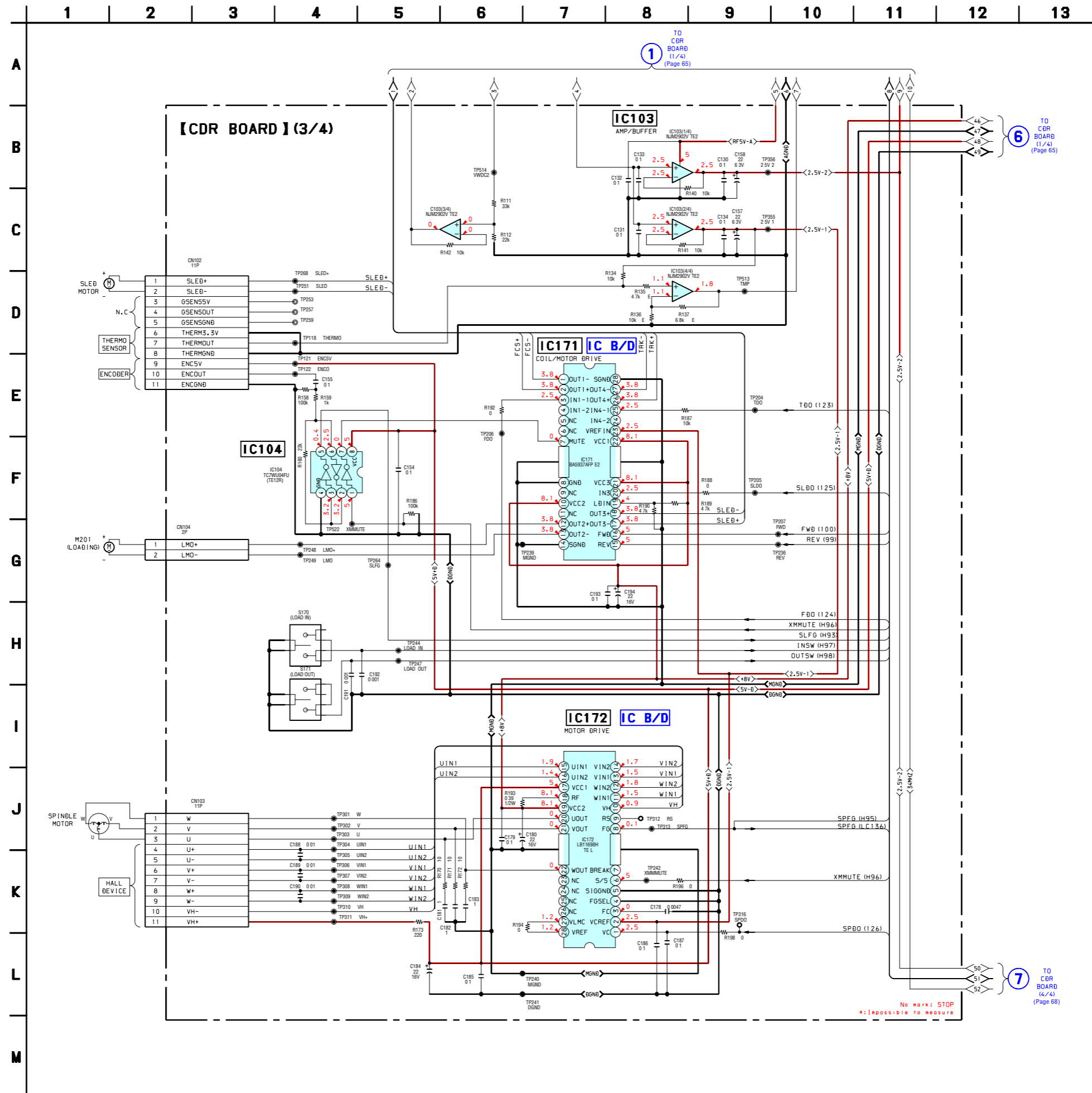

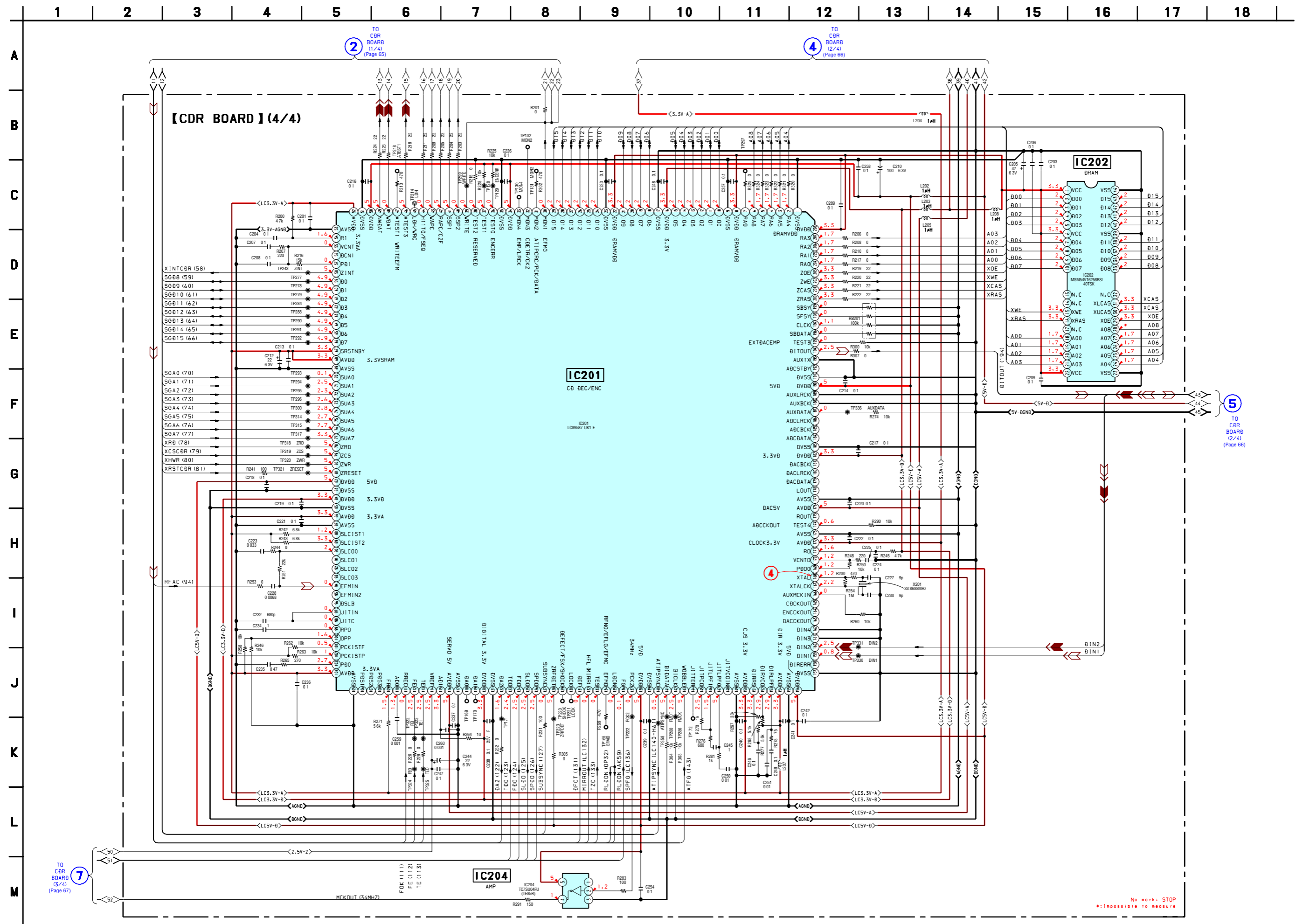

No mark: STOP
*: impossible to measure

6-12. Printed Wiring Boards – Main Section (Side A) – • See page 55 for Circuit Boards Location. •  : Uses unleaded solder.

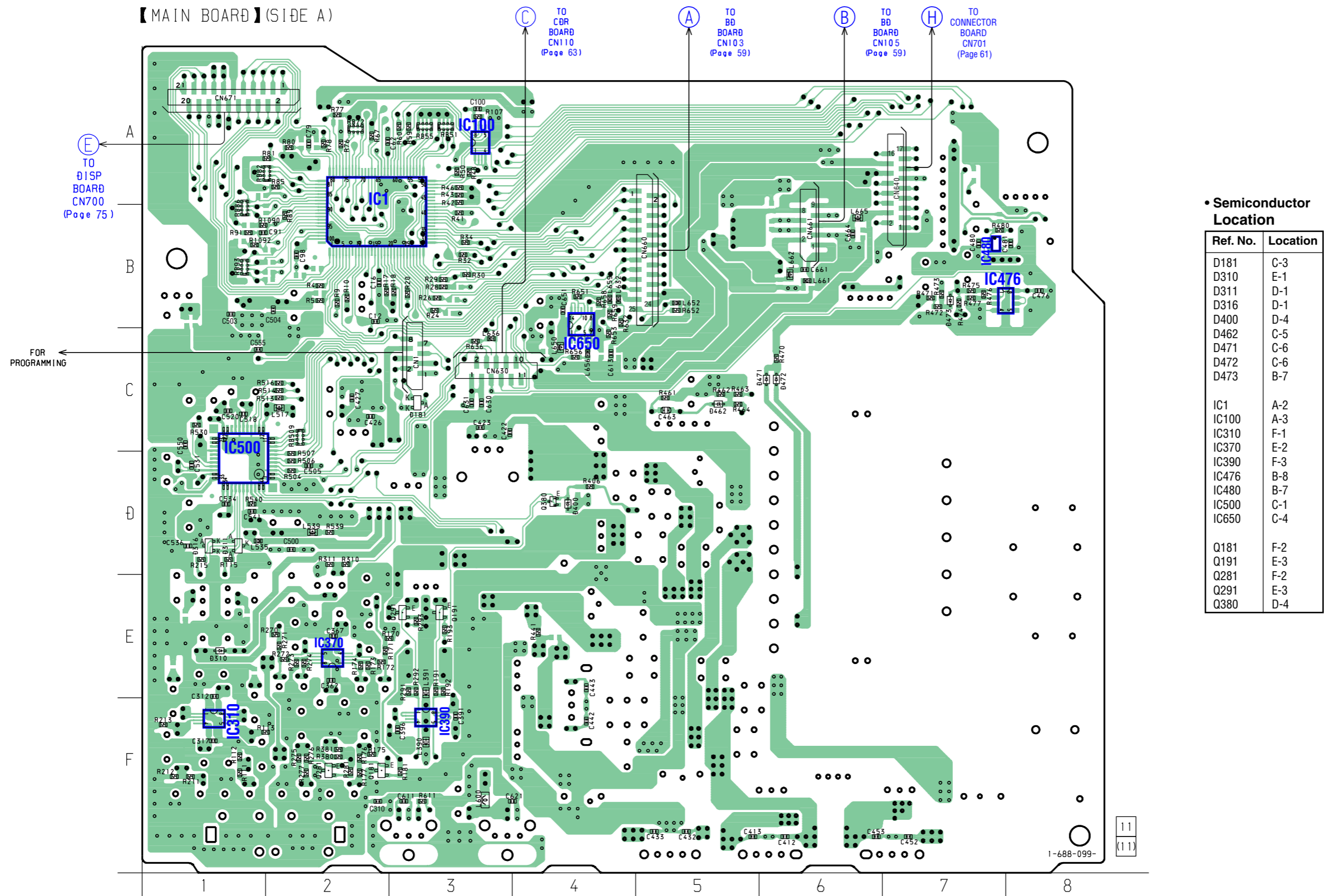

• Semiconductor Location

Ref. No.	Location
D181	C-3
D310	E-1
D311	D-1
D316	D-1
D400	D-4
D462	C-5
D471	C-6
D472	C-6
D473	B-7
IC1	A-2
IC100	A-3
IC310	F-1
IC370	E-2
IC390	F-3
IC476	B-8
IC480	B-7
IC500	C-1
IC650	C-4
Q181	F-2
Q191	E-3
Q281	F-2
Q291	E-3
Q380	D-4

【 MAIN BOARD 】 (SIDE B)

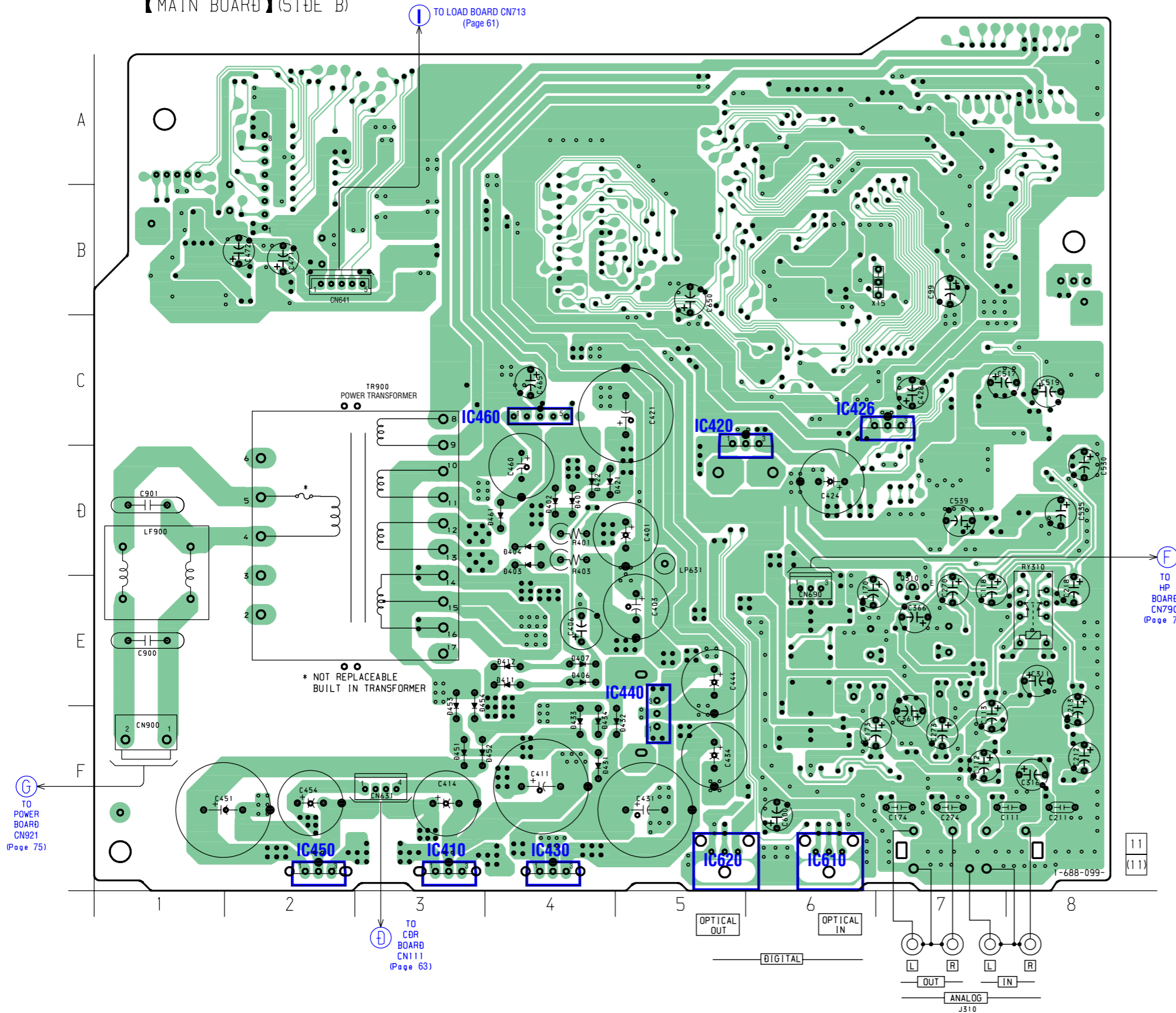

• Semiconductor Location

Ref. No.	Location
D401	D-4
D402	D-4
D403	D-4
D404	D-4
D406	E-4
D407	E-4
D411	E-4
D412	E-4
D421	D-5
D422	D-4
D431	F-4
D432	F-5
D433	F-4
D434	F-4
D451	F-3
D452	F-4
D453	E-3
D454	E-3
D461	D-4
IC410	F-3
IC420	C-5
IC426	C-6
IC430	F-4
IC440	E-5
IC450	F-2
IC460	C-4
IC610	F-6
IC620	F-5
Q310	D-7

6-14. Schematic Diagrams – Main Section (1/2) – • See page 55 for Waveform. • See page 82 for IC Block Diagrams. • See page 84 for IC Pin Function.

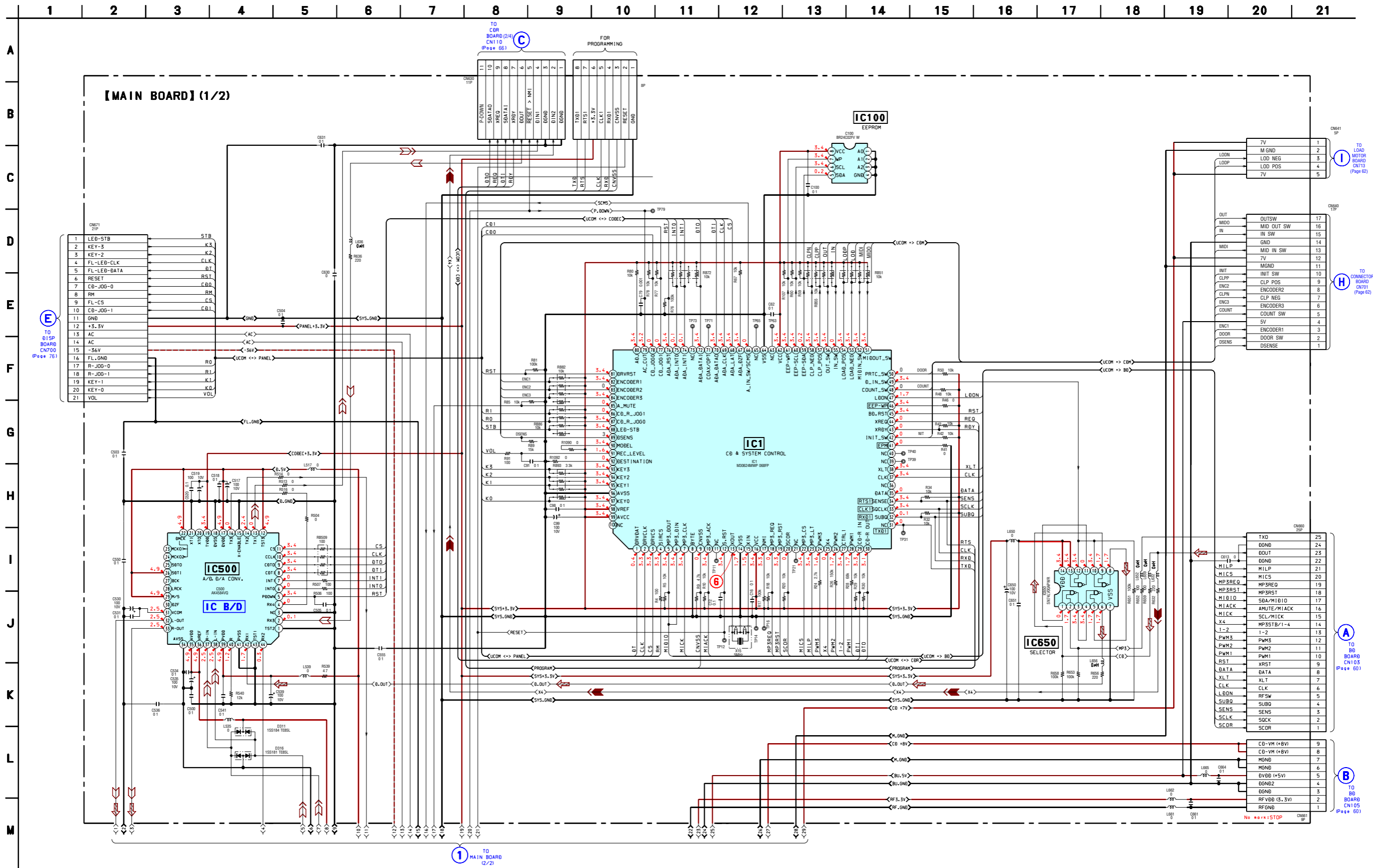

RCD-W500C

6-15. Schematic Diagrams – Main Section (2/2) – • See page 81 for IC Block Diagrams.

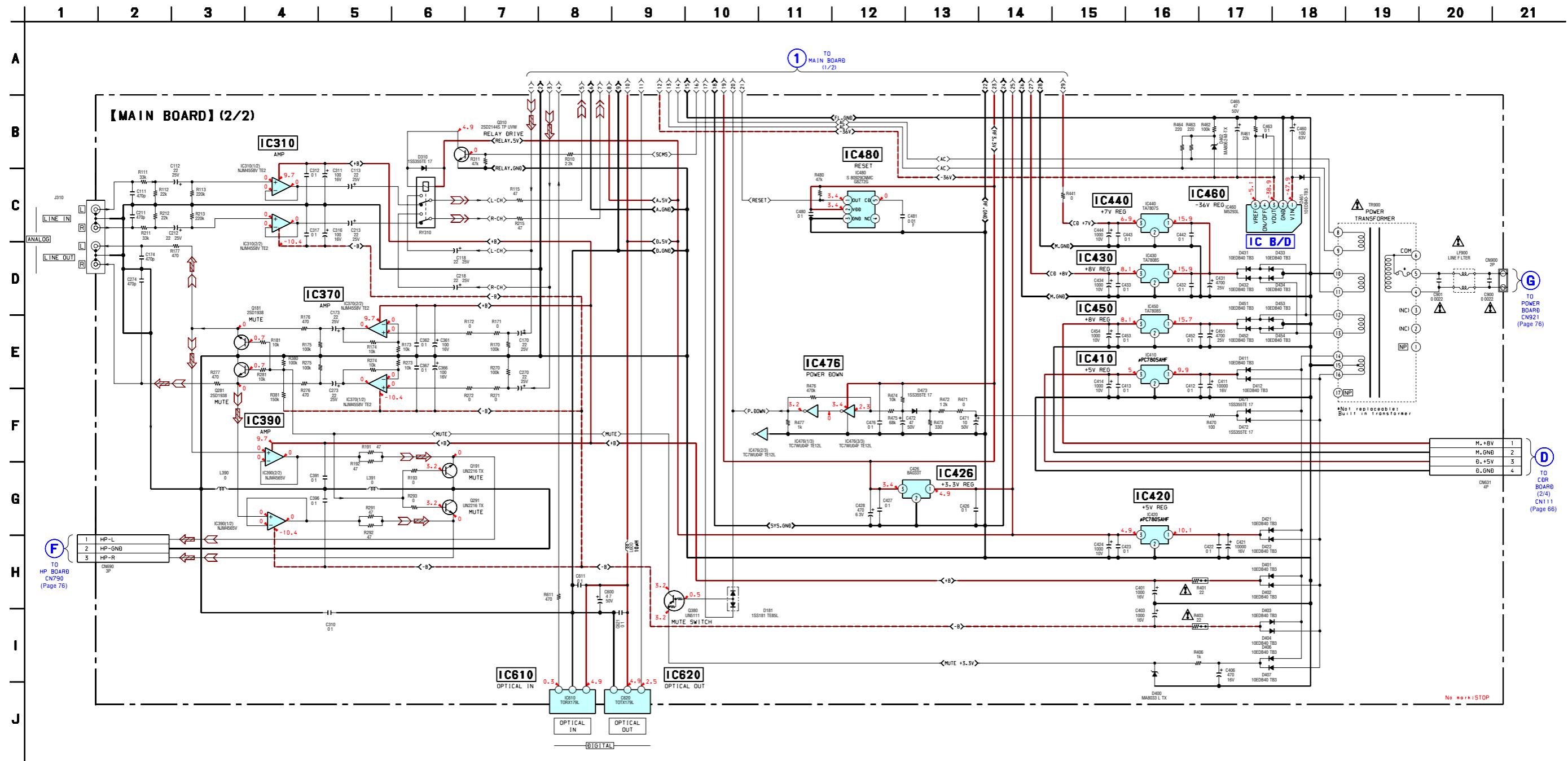

6-16. Printed Wiring Boards – Led Section – • See page 55 for Circuit Boards Location. •  : Uses unleaded solder.

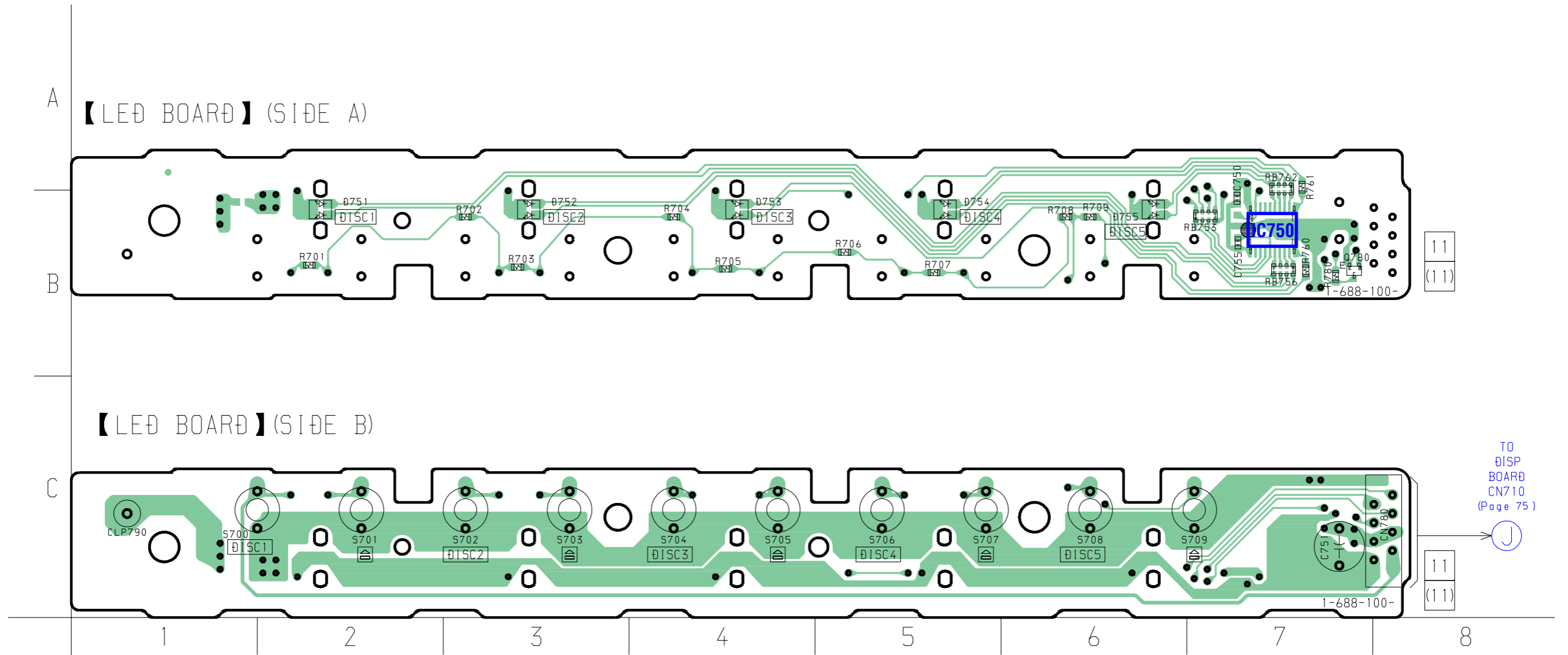

• Semiconductor Location

Ref. No.	Location
D751	B-2
D752	B-3
D753	B-4
D754	B-5
D755	B-6
IC750	B-7
Q780	B-7

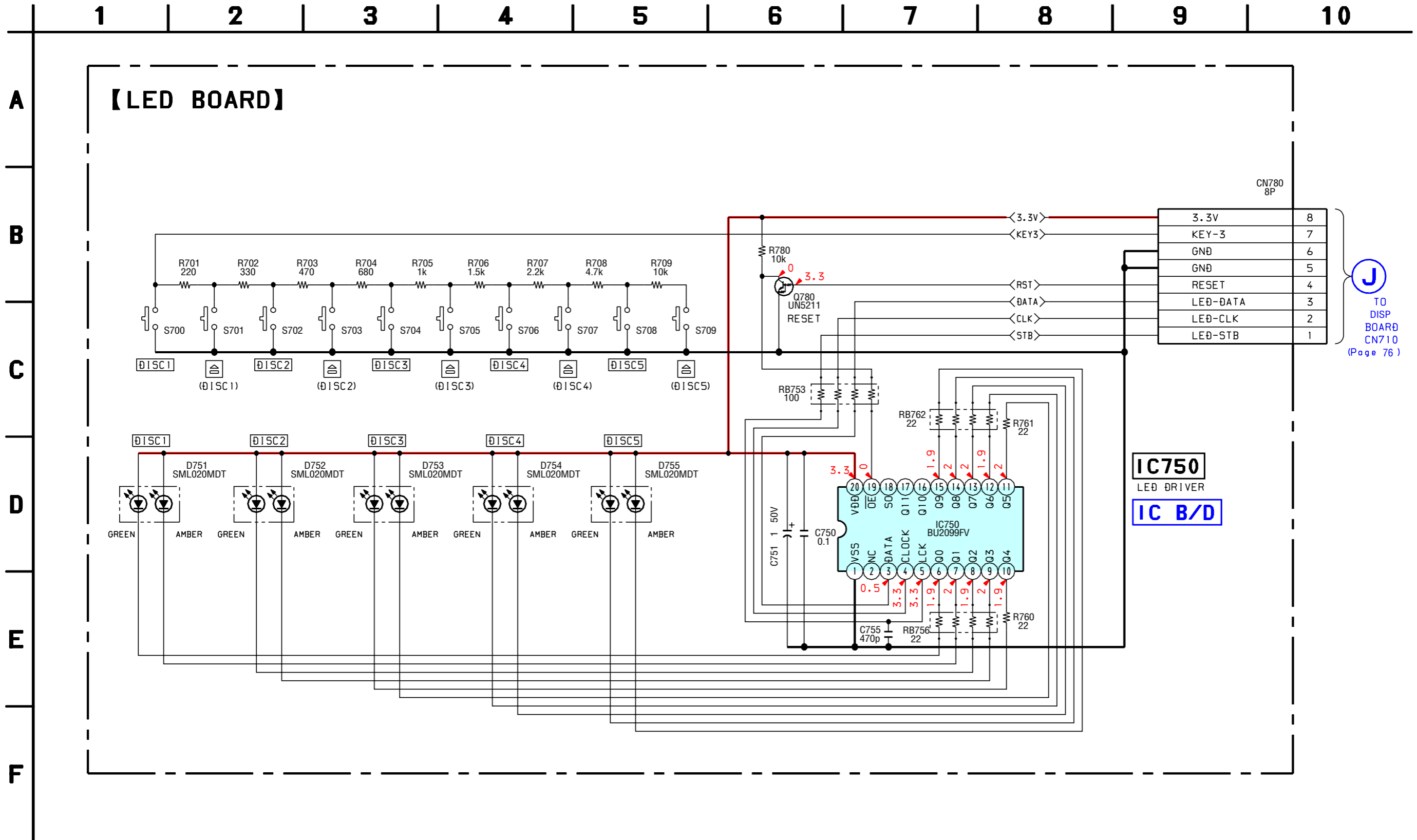

J
TO DISP BOARD CN710 (Page 76)

6-18. Printed Wiring Boards – Display Section – • See page 55 for Circuit Boards Location. •  : Uses unleaded solder.

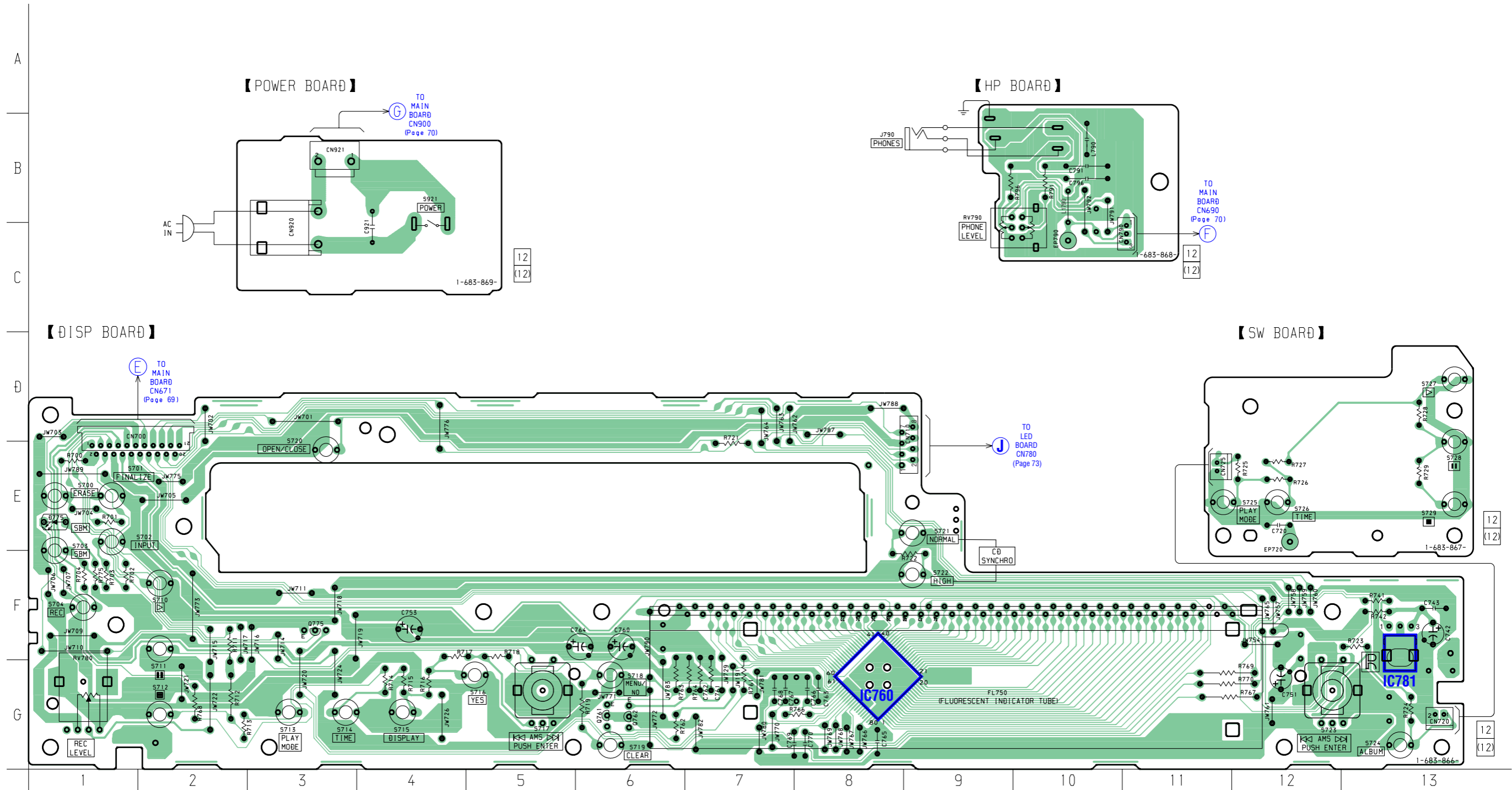

RCD-W500C

6-19. Schematic Diagrams – Display Section – • See page 83 for IC Block Diagrams.

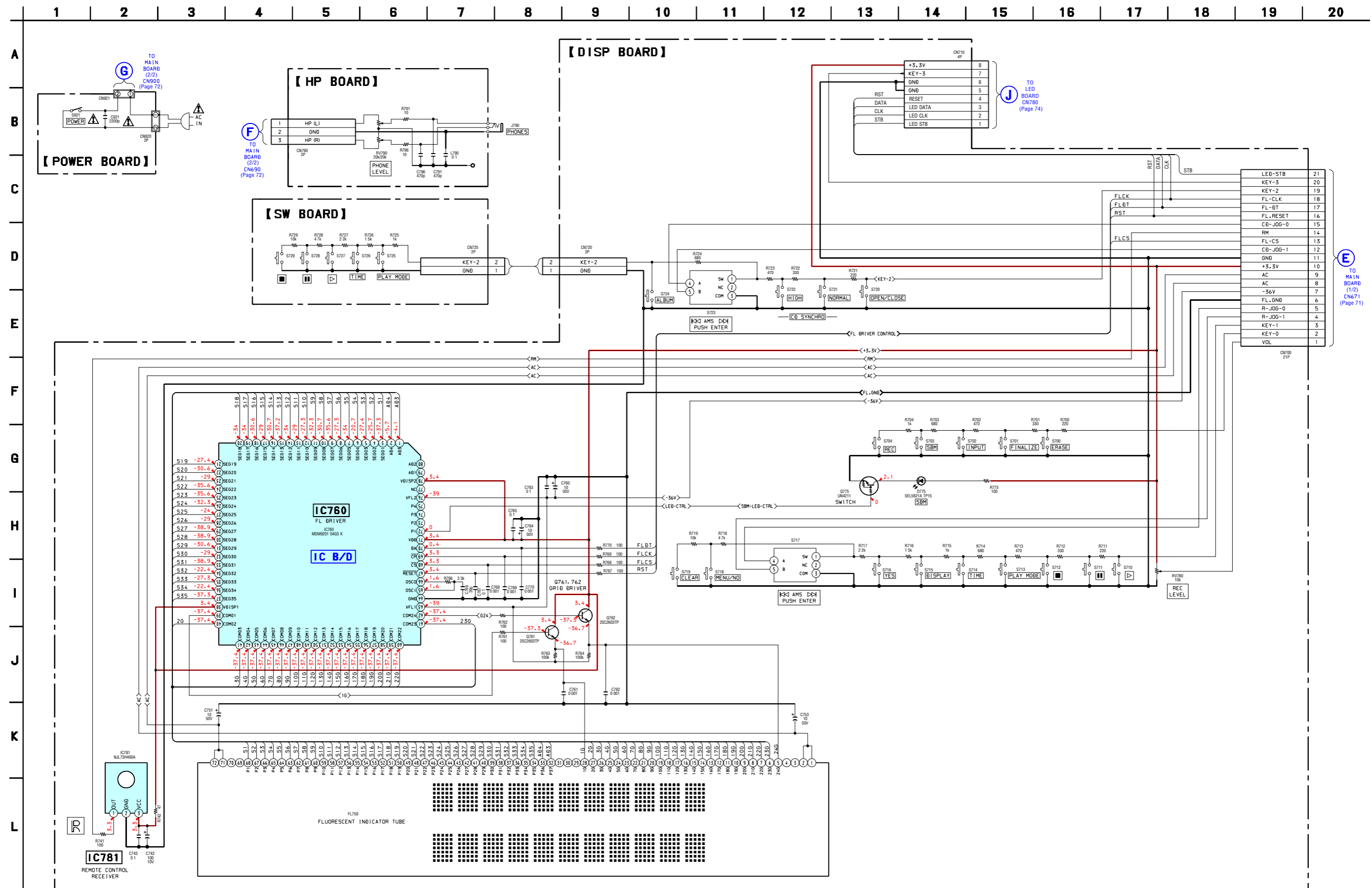

6-20. IC Block Diagrams

IC101 CXD3068Q (BD Board)

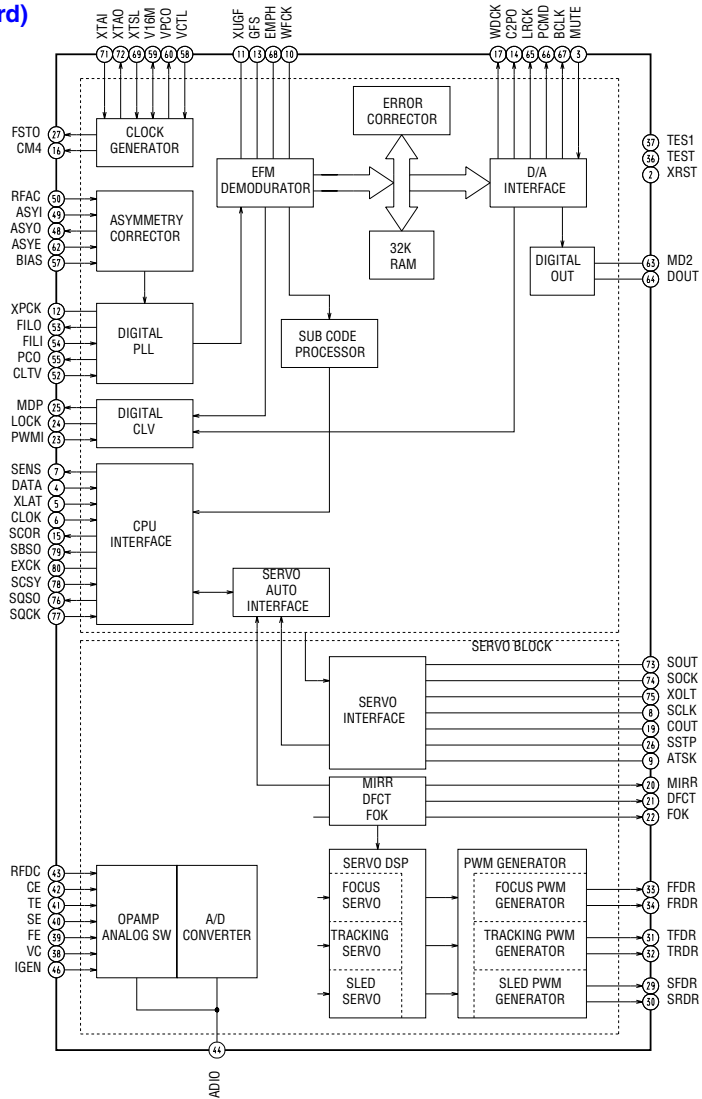

IC102 AN41050 (BD Board)

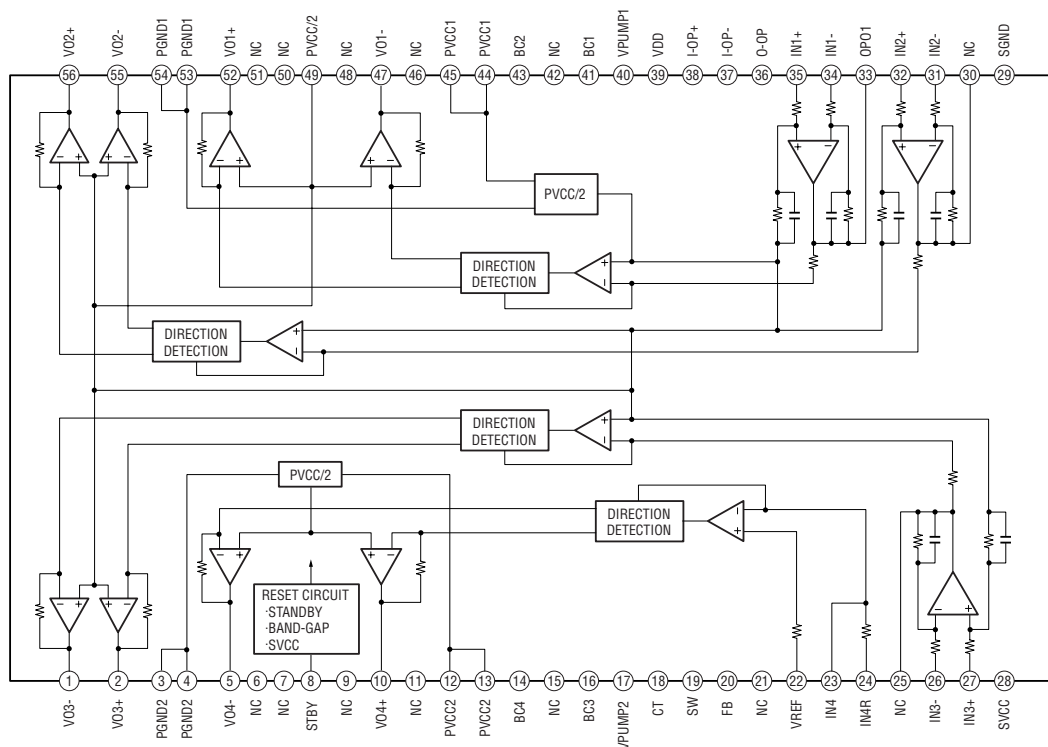

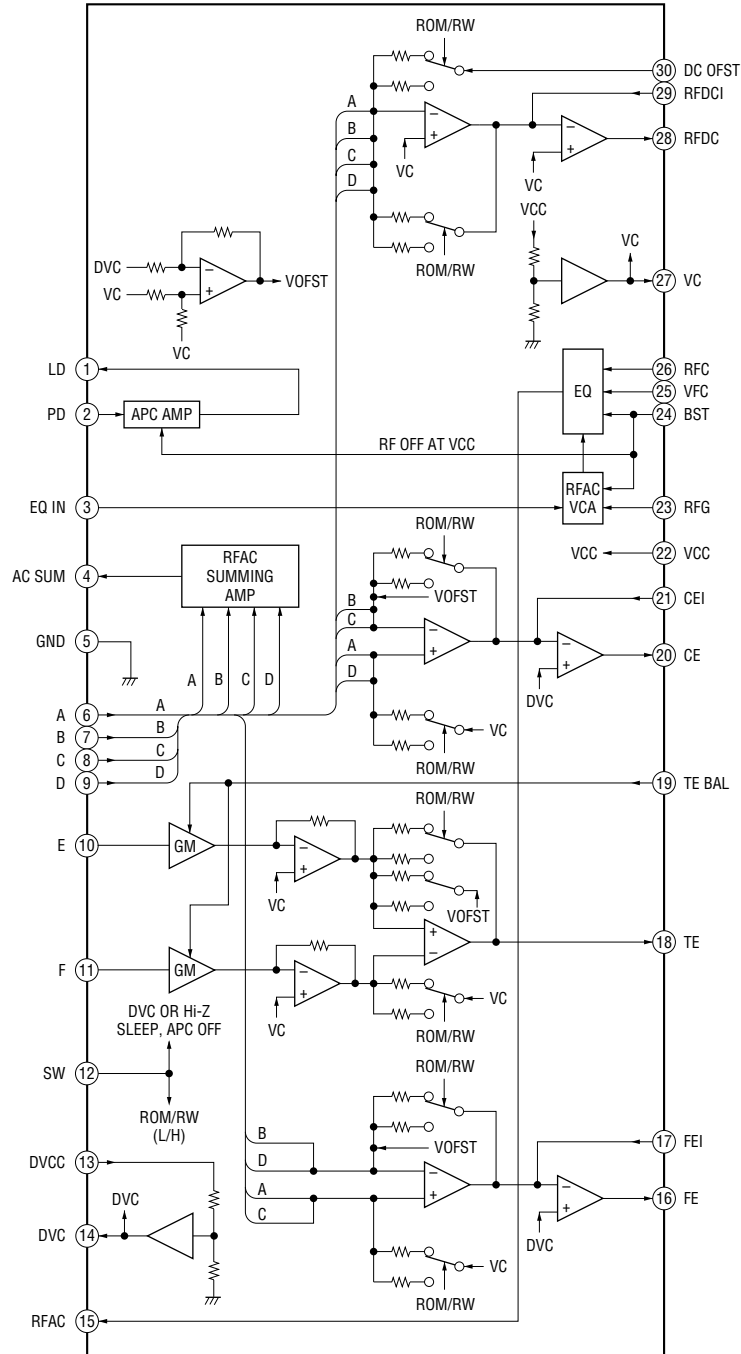

IC104 CXD9717R-008 (BD Board)

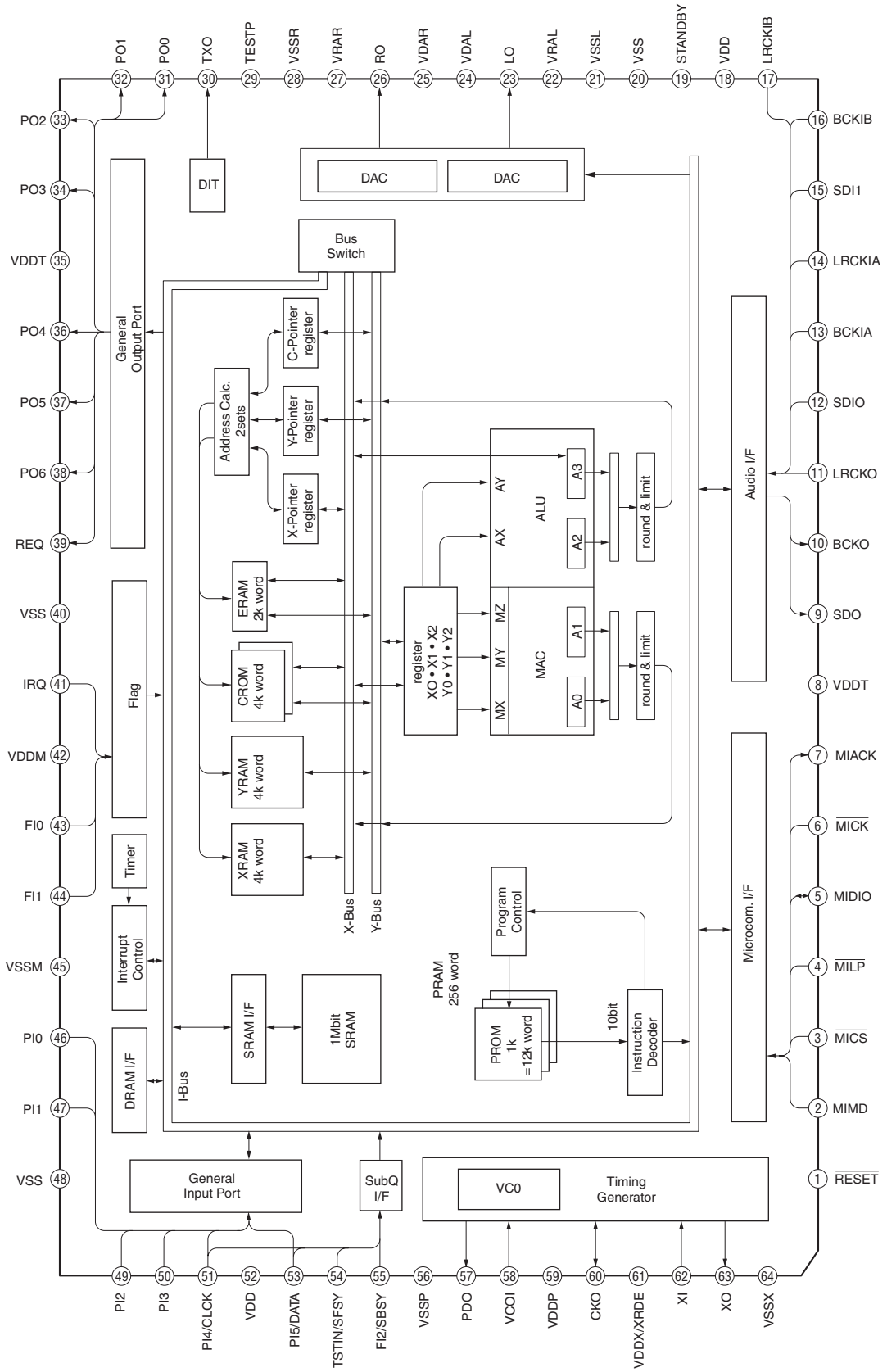

RCD-W500C

IC171 BA5937AFP-E2 (CDR Board)

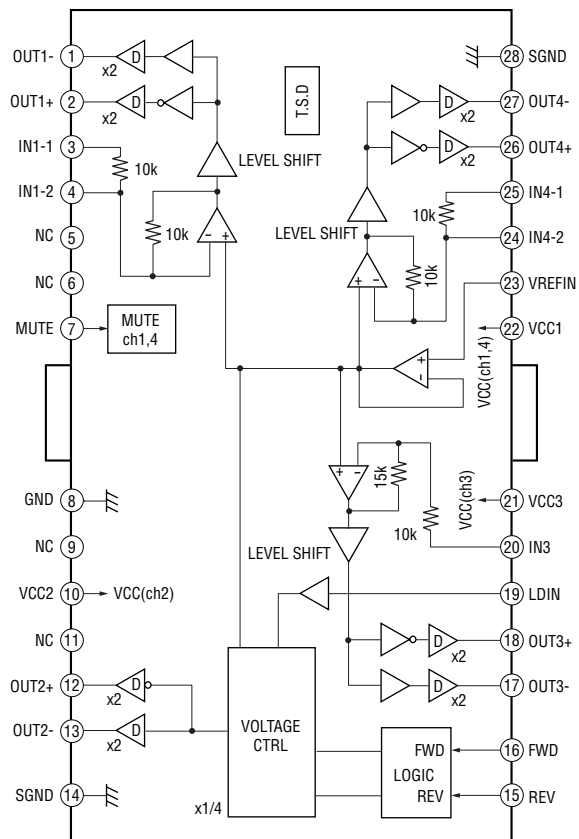

IC172 LB11698H-TE-L (CDR Board)

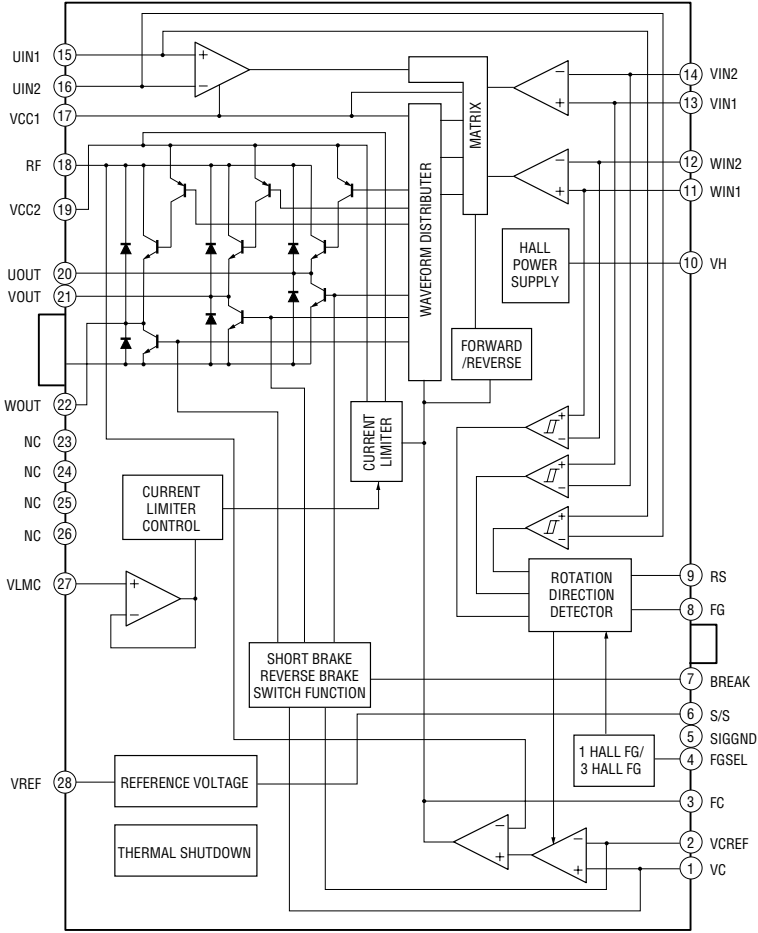

IC460 M5293L (MAIN Board)

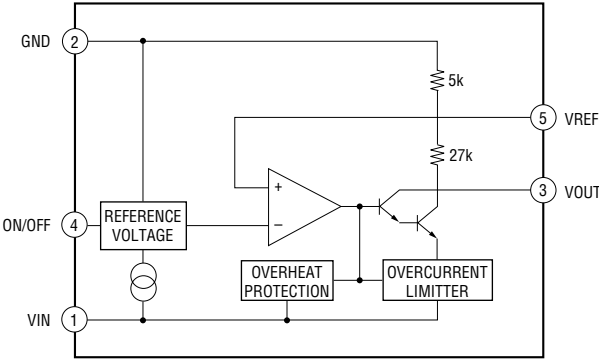

RCD-W500C

IC500 AK4584VQ (MAIN Board)

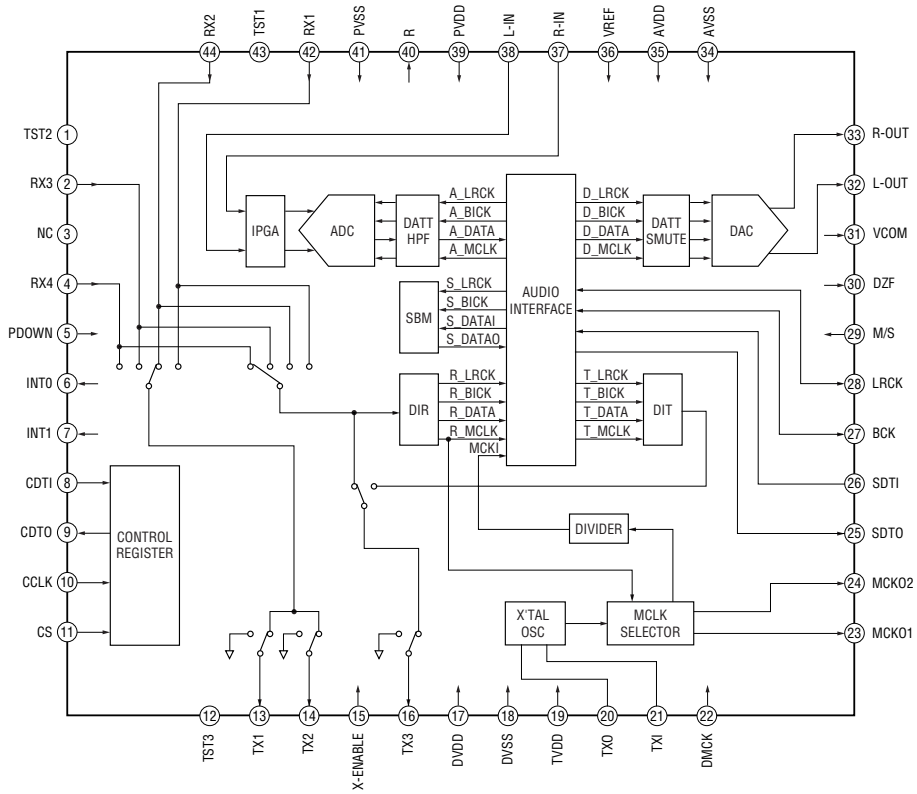

IC750 BU2099FV (LED Board)

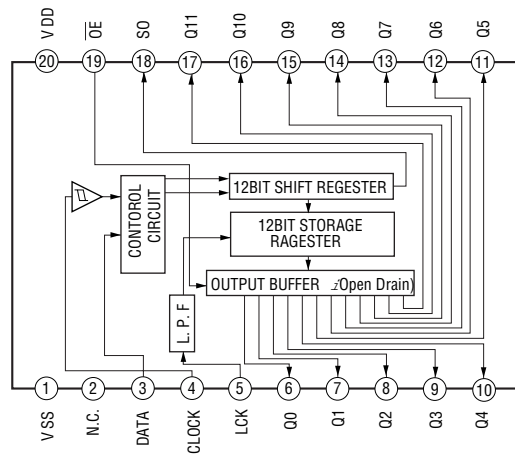

IC760 MSM9201-04GS-K (DISP Board)

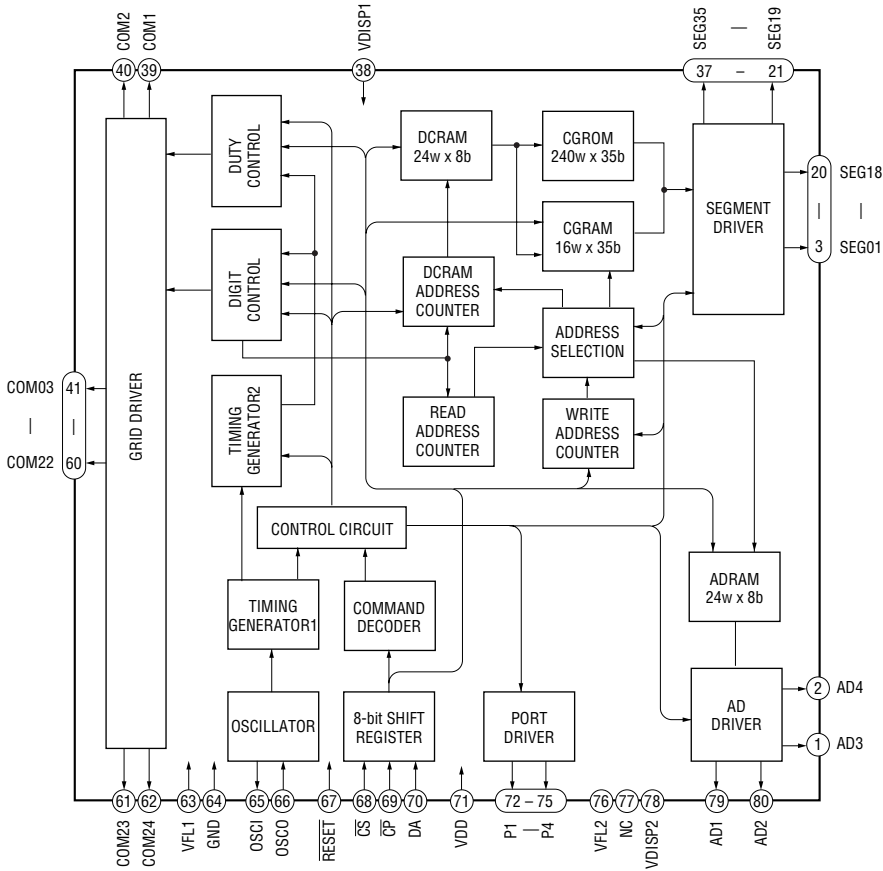

IC701 M54641L (CLAMP MOTOR Board)
 IC702 M54641L (LOAD MOTOR Board)

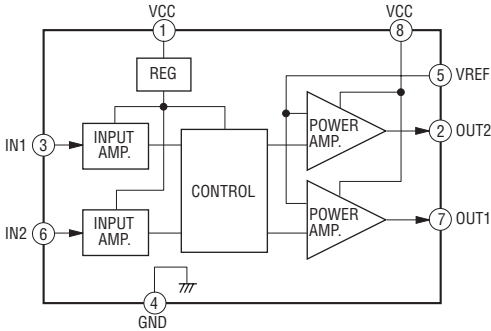

6-21. IC Pin Function Description

• IC1 M30624MWP-068FP CD & SYSTEM CONTROL (MAIN Board)

Pin No.	Pin Name	I/O	Description
1	DRV DAT	O	Data output to the FL driver (IC760) and the LED driver (IC750)
2	DRV CLK	O	Clock output to the FL driver (IC760) and the LED driver (IC750)
3	DRV CS	O	Chip select signal output to the FL driver (IC760)
4	SIRCS	I	Remote control signal input from the remote control receiver (IC781)
5	MP3_DOUT	O	Serial data output to the MP3 decoder (IC104)
6	MP3_DIN	I	Serial data input from the MP3 decoder (IC104)
7	MP3_CLK	O	Serial clock output to the MP3 decoder (IC104)
8	BYTE	I	External data bus width setting terminal ("L" : single chip)
9	CNVSS	I	Processor mode setting terminal ("L" : single chip)
10	MP3_ACK	I	Acknowledge signal input from the MP3 decoder (IC104)
11	NC	O	Not used (open)
12	S.RST	I	System reset signal input
13	XOUT	O	Resonator terminal for main clock (5MHz)
14	VSS	—	Ground terminal
15	XIN	I	Resonator terminal for main clock (5MHz)
16	VCC	—	Power supply terminal
17	NMI	I	Non maskable interrupt signal input terminal (pull-up)
18	MP3_REQ	I	Request signal input from the MP3 decoder (IC104)
19	MP3_RESET	O	Reset signal output to the MP3 decoder (IC104)
20	SCOR	I	Sub-code sync (S0+S1) detection signal input from the DSP (IC101)
21	NC	O	Not used (open)
22	MP3_CS	O	Chip select signal output to the MP3 decoder (IC104)
23	MP3_LT	O	Latch signal output to the MP3 decoder (IC104)
24	PWM3	O	PWM signal output for RFDC
25	X4	O	Disc rotation speed selection signal output
26	PWM2	O	PWM signal output for TE
27	CTRL1	O	Disc rotation speed selection signal output
28	PWM1	O	PWM signal output for FE
29	CD-R IN	I	Data input from the microcomputer (IC501)
30	CD-R OUT	O	Data output to the microcomputer (IC501)
31	NC	O	Not used (open)
32	SUBQ	I	Sub code Q serial data input
33	SQCLK	O	Sub code Q serial clock output
34	SENSE	I	SENSE signal input from the DSP (IC101)
35	DATA	O	Data output to the DSP (IC101)
36	NC	O	Not used (open)
37	CLK	O	Clock output to the DSP (IC101)
38	XLT	O	Latch signal output to the DSP (IC101)
39	NC	O	Not used (open)
40	NC	O	Not used (open)
41	EPM	I	Flash programming terminal (pull-down)
42	INIT_SW	I	INIT detection switch signal input
43	XRDY	I	Data ready signal input from the microcomputer (IC501)
44	XREQ	O	Data request signal output to the microcomputer (IC501)
45	BD_RESET	O	Reset signal output to the DSP (IC101) and the motor/coil driver (IC102) ("L" : reset)
46	EEP-WP	I	Flash programming terminal (pull-up)
47	LDON	O	Laser on signal output
48	COUNT_SW	I	COUNT detection switch signal input
49	DIGITAL_IN_SW	O	Digital input selection signal output to the selector (IC650)
50	PRTC_SW	I	DOOR detection switch signal input

Pin No.	Pin Name	I/O	Description
51	MIDOUT_SW	I	MIDOUT detection switch signal input
52	MIDIN_SW	I	MIDIN detection switch signal input
53	LOAD_NEG	O	Loading motor control signal output
54	LOAD_POS	O	Loading motor control signal output
55	IN_SW	I	Tray open/close detection signal input
56	OUT_SW	I	Tray open/close detection signal input
57	CLP_POS	O	Elevator up/down motor control signal output
58	CLP_NEG	O	Elevator up/down motor control signal output
59	EEP-SDA	O	IIC data input/output from/to the EEPROM (IC100)
60	EEP-SCL	O	IIC clock input/output from/to the EEPROM (IC100)
61	EEP-WP	O	Write protect signal output the EEPROM (IC100)
62	VCC	—	Power supply terminal
63	NC	O	Not used (open)
64	VSS	—	Ground terminal
65	NC	O	Not used (open)
66	A_IN_SW/SCMS	O	Analog line selection signal output (SCMS on at SYNC mode)
67	ADA_DZF	I	Not used (pull-up)
68	ADA_LAT	O	Data latch signal output to the AD/DA converter (IC500)
69	ADA_CLK	O	Clock output to the AD/DA converter (IC500)
70	ADA_DATAO	O	Data output to the AD/DA converter (IC500)
71	COAX/OPT	O	Not used (open)
72	ADA_DATAI	I	Data input from the AD/DA converter (IC500)
73	NC	O	Not used (open)
74	ADA_INT1	I	Interrupt signal input from the AD/DA converter (IC500)
75	ADA_INT0	I	Interrupt signal input from the AD/DA converter (IC500)
76	ADA_RST	O	Reset signal output to the AD/DA converter (IC500)
77	CD_JOG1	I	CD jog signal input
78	CD_JOG0	I	CD jog signal input
79	AC_CUT	I	AC cut signal input (“L” : AC cut)
80	ADJ	I	ADJ mode setting terminal (“L” : ADJ mode)
81	DRVRST	O	Reset signal output to the FL driver (IC760) and the LED driver (IC750)
82	ENCODER1	I	Disc tray address detection signal input from the rotary encoder
83	ENCODER2	I	Disc tray address detection signal input from the rotary encoder
84	ENCODER3	I	Disc tray address detection signal input from the rotary encoder
85	A_MUTE	O	Muting control signal output (“L” : muting on)
86	CD_R_JOG1	I	CD-R jog signal input
87	CD_R_JOG0	I	CD-R jog signal input
88	LED-STB	O	Strobe signal output to the LED driver (IC750)
89	DSSENS	I	Disc in detection sensor signal input
90	MODEL	I	Model setting terminal
91	REC_LEVEL	I	Analog recording level signal input from the RV780
92	DESTINATION	I	Destination setting terminal
93	KEY3	I	Key data AD input
94	KEY2	I	Key data AD input
95	KEY1	I	Key data AD input
96	AVSS	—	Ground terminal (analog)
97	KEY0	I	Key data AD input
98	VREF	—	Analog reference voltage input terminal
99	AVCC	—	Power supply terminal (analog)
100	NC	O	Not used (open)

• IC101 AK8567 RF AMP (CDR Board)

Pin No.	Pin Name	I/O	Description
1	AVDD3	—	Power supply (analog)
2	BCENT	O	Center signal output
3	PHBETA	O	β signal top level signal output
4	BHBETA	O	β signal bottom level signal output
5	PHBTC	O	External capacitor terminal for PHBETA droop rate setting
6	BHBTC	O	External capacitor terminal for BHBETA droop rate setting
7	MPP	O	Main push-pull signal output Not used (open)
8	TEIN	I	Tracking signal processing input
9	TE	O	Tracking error signal output
10	FE	O	Focus error signal output
11	SBAD	O	SBAD signal output Not used (open)
12	TZCLVL	I	Tracking zero cross compare level input
13	VREF	I/O	Decoupling terminal for internal reference voltage / internal reference voltage input terminal
14	AGND1	O	Decoupling terminal for internal reference voltage
15	BIAS	O	Bias resistor connection terminal BIAS = 4.7k Ω
16	VSS	—	Ground terminal (analog)
17	FVREF	I	APC reference voltage input terminal
18	FPDO	I	Laser monitor voltage input
19	RREF	I/O	Power setting voltage input for read APC / internal DAC setting voltage output
20	VRDC	O	Read laser driver control signal output
21	VRDCN	I	Read laser driver control amplifier (-) terminal
22	VRDCN2	I	Read laser driver time constant setting terminal
23	WREF	I/O	Power setting voltage input for write APC / internal DAC setting voltage output
24	WDAO	O	Power setting internal DAC voltage output for write APC Not used (open)
25	AVDD2	—	Power supply (analog)
26	AVSS2	—	Ground terminal (analog)
27	VWDC	O	Write laser driver control signal output
28	VWDCN2	I	Write laser driver time constant setting terminal
29	VWDCN	I	Write laser driver control amplifier (-) terminal
30	ATFM	O	Wobble signal output Not used (open)
31	AGC1C	O	External capacitor terminal for AGC response speed setting
32	AGC2C	O	External capacitor terminal for AGC response speed setting
33	AGC3C	O	External capacitor terminal for AGC response speed setting
34	AGND2	O	Decoupling terminal for internal reference voltage
35	VSS	—	Ground terminal (analog)
36	SGAINDN	I	Gain selection signal input
37	GAINUP	I	CD-RW selection control signal input
38	AGCON	I	Wobble AGC enable signal input "H" : AGC ON, "L" : AGC reset
39	ATFG	O	ATIP FG signal output (Wobble signal after formation of 2 values)
40	XTOR	O	Tracking amplitude detection signal output Not used (open)
41	XTAND	O	Tracking failure detection signal output
42	TZC	O	Tracking zero cross detection signal output
43	RECD2	O	Recorded block detection signal output 2 "H" : recorded block, "L" : unrecorded block
44	RECD1	O	Recorded block detection signal output 1 "H" : recorded block, "L" : unrecorded block
45	RC	O	RC signal output
46	DFCT	O	DFCT signal output
47	MIRR	O	MIRR signal output
48	MCLK1	I	Main clock input 1 (sine wave input) 34.5744MHz
49	MCLK2	I	Main clock input 2 (sine wave input) fixed at "L"
50	DVSS	—	Ground terminal (digital)

Pin No.	Pin Name	I/O	Description
51	DVDD	—	Power supply (digital)
52	FOK	O	FOK signal output
53	RZC	O	RF zero cross detection signal output Not used (open)
54	MPDSH	I	Sampling pulse input for main beam signal “H” : sample, “L” : hold
55	SPDSH	I	Sampling pulse input for side beam signal “H” : sample, “L” : hold
56	RFPDSH	I	Sampling pulse input for read APC “H” : sample, “L” : hold
57	WFPDSH	I	Sampling pulse input for write APC “H” : sample, “L” : hold
58	WLDON	I	Write LD control signal input “H” : set write APC value to zero, “L” :LD ON
59	RLDON	I	Read LD control signal input “H” : set read APC value to zero, “L” :LD ON
60	SPBLVL	I	BLEVEL sampling pulse input “H” : sample, “L” : hold
61	SPRFTR	I	WRFTR sampling pulse input “H” : sample, “L” : hold
62	VWDSW	I	Write laser driver time constant setting switch control signal input “H” : ON, “L” : OFF
63	VRDSW	I	Read laser driver time constant setting switch control signal input “H” : ON, “L” : OFF
64	RSBETA	I	β measuring circuit reset signal input “H” : reset the outputs of PHBETA and BHBETA
65	SCLK	I	Clock input for register setting
66	SDATA	I	Serial data input for register setting
67	XLAT	I	Latch signal input for register setting
68	XRST	I	Register reset terminal “L” : reset
69	VSS	—	Ground terminal (analog)
70	OSTCC	O	Capacitor connection terminal for setting fc of the equalizer output offset canceller
71	AGCC	O	External capacitor connection terminal for setting the RFAGC response speed
72	PHD2C	O	External capacitor connection terminal for setting the P/H2 droop rate
73	RCCMPI	I	RC detection comparator input
74	PBHO	O	Bottom/top level output of RRF signal
75	AVDD1	—	Power supply (analog)
76	AVSS1	—	Ground terminal (analog)
77	RRFTOP	O	Peak level output of RRF signal Not used (open)
78	RRFBTM	O	Bottom level output of RRF signal Not used (open)
79	N.C.	—	Not used (ground)
80	EQRF	O	Equalizer filter output
81	N.C.	—	Not used (ground)
82	AUX1	I	Auxiliary input terminal (1) for monitoring signal Not used
83	AUX2	I	Auxiliary input terminal (2) for monitoring signal from the CN115 Not used
84	AUX3	I	Auxiliary input terminal (3) for monitoring VWDC2 signal from the optical pick-up
85	MPXOUT	O	Multiplexer signal output for the signal monitoring
86	RRFVC(1V)	I	Level shift voltage input terminal for RRF signal
87	RECDIN	I	RF signal input for the recorded block detection
88	RRF	O	Read RF signal output
89	WRF	O	Write RF signal output (open)
90	VSS	—	Ground terminal (analog)
91	AIN	I	Main beam signal (A) input
92	BIN	I	Main beam signal (B) input
93	CIN	I	Main beam signal (C) input
94	DIN	I	Main beam signal (D) input
95	EIN	I	Side beam signal (E) input
96	FIN	I	Side beam signal (F) input
97	GIN	I	Side beam signal (G) input
98	HIN	I	Side beam signal (H) input
99	HAVC	I	Main/side beam signal center voltage input
100	AVSS3	—	Ground terminal (analog)

• IC201 LC89587-UK1-E CD DEC/ENC (CDR Board)

Pin No.	Pin Name	I/O	Description
1	DVSS	—	Ground terminal (digital)
2 to 6	RA4 to RA8	O	Address signal output to the buffer RAM for audio data delay
7	RA9	O	Address signal output to the buffer RAM for audio data delay Not used (open)
8	DVDD	—	Power supply +3.3V (DRAM I/F)
9	DVSS	—	Ground terminal (digital)
10 to 15	IO0 to IO5	I/O	Data input/output to the buffer RAM for audio data delay
16	DVDD	—	Power supply +3.3V (digital)
17	DVSS	—	Ground terminal (digital)
18 to 21	IO6 to IO9	I/O	Data input/output to the buffer RAM for audio data delay
22	DVDD	—	Power supply +3.3V (DRAM I/F)
23	DVSS	—	Ground terminal (digital)
24 to 29	IO10 to IO15	I/O	Data input/output to the buffer RAM for audio data delay
30	MON1	O	Monitor output EFMG signal
31	MON2	O	Monitor output ATIPCRC/PCK/DATA signal (open)
32	MON3	O	Monitor output CDETR/CK2 signal (open)
33	MON4	O	Monitor output EMP/LRCK signal (open)
34	DVDD	—	Power supply +5V (digital)
35	DVSS	—	Ground terminal (digital)
36	TEST0	I/O	ENCERR signal output (pull-up)
37	TEST1	I/O	TESTOUT signal output (pull-up)
38	TEST2	I/O	TESTIN signal input (ground)
39	WRITE	I	Write strategy signal control terminal
40	SSP2	O	Servo sampling pulse output
41	SSP1	O	Servo sampling pulse output
42	RAPC/C2F	O	Laser sampling pulse output
43	WAPC	O	Laser sampling pulse output
44	H11TO/FSEQ	O	Running OPC sampling pulse output
45	LDH/WRQ	O	LD control signal output for recording Not used (open)
46	ATEST3	O	Analog block test signal output (WE2)
47	ATEST1	O	Analog block test signal output Not used (open)
48	WDAT	O	LD control signal output for recording
49	NWDAT	O	LD control signal output for recording
50	DVDD	—	Power supply +5V (digital)
51	DVSS	—	Ground terminal (digital)
52	AVDD	—	Power supply 3.3V (analog) for the write strategy
53	AVSS	—	Ground terminal (analog)
54	R1	I	Analog terminal for the write strategy (fixed at "H")
55	VCNT1	I	Analog terminal for the write strategy
56	DCN1	I	Analog terminal for the write strategy Not used (open)
57	PD1	O	Analog terminal for the write strategy
58	ZINT	O	Interrupt request signal output to the μ com (IC501)
59 to 66	D0 to D7	I/O	Data input/output with the μ com (IC501)
67	SRSTNBY	I	Back up control terminal for CD-TEXT SRAM
68	AVDD	—	Power supply +3.3V (analog) for CD-TEXT SRAM
69	AVSS	—	Ground terminal (analog)
70 to 77	SUA0 to SUA7	I	Command register selection address signal input
78	ZRD	I	Data read out signal input from the μ com (IC501)
79	ZCS	I	Chip select signal input from the μ com (IC501)
80	ZWR	I	Data write signal input from the μ com (IC501)
81	ZRESET	I	Reset signal input

Pin No.	Pin Name	I/O	Description
82	DVDD	—	Power supply +5V (digital)
83	DVSS	—	Ground terminal (digital)
84	DVDD	—	Power supply +3.3V (digital)
85	DVSS	—	Ground terminal (digital)
86	AVDD	—	Power supply +3.3V (analog) for slice level setting
87	AVSS	—	Ground terminal (analog)
88, 89	SLCIST1, SLCIST2	I	EFM slice level setting signal input
90 to 93	SLCO0 to SLCO3	O	EFM slice level output
94	EFMIN	I	EFM signal input
95	EFMIN2	I	EFM signal input Not used (open)
96	DSL B	O	PWM signal output for SLC Not used (open)
97	JITIN	I	Jitter judgement input
98	JITC	O	Jitter output
99	RPO	O	P/N balance adjustment terminal
100	OPP	I	P/N balance adjustment terminal
101	PCKISTF	I	Charge pump terminal for the frequency comparison
102	PCKISTP	I	Charge pump terminal for the phase comparison
103	PD0	O	Filter for the charge pump
104	AVDD	—	Power supply +3.3V (analog) for the charge pump
105	AVSS	—	Ground terminal (analog)
106 to 108	PDS1 to PDS3	O	Charge pump selection terminal Not used (open)
109	FR	I	VCO frequency setting input terminal
110	AD0	I	AD input
111	RREC	I	FOK signal input for optical judgement
112	FE	I	Focus error signal input
113	TE	I	Tracking error signal input
114	VREF	I	Servo system reference voltage input
115	AD1	I	AD input
116	AVDD	—	Power supply +5V (analog) for the servo block AD/DA
117	AVSS	—	Ground terminal (analog)
118, 119	DA0, DA1	O	DA output Not used (open)
120	DVDD	—	Power supply +3.3V (digital)
121	DVSS	—	Ground terminal (digital)
122	DA2	O	DA output
123	TDO	O	Tracking signal output
124	FDO	O	Focus signal output
125	SLDO	O	Sled signal output
126	SPDO	O	Spindle signal output
127	SUBSYNC	O	Sub-code sync signal output
128	ZRFDET	I	Judgement signal input for the existence of RF signal (fixed at "H")
129	SHOCK	O	Shock detection signal output Not used (open)
130	LOCK	O	PLL lock status signal output Not used (open)
131	DEF	I	Defect detection signal input
132	HFL(MIRR)	I	MIRR detection signal input
133	TES	I	Tracking zero cross signal input
134	EFMO	O	EFM signal output after formation of 2 values (open)
135	LDON	O	Laser control signal output for play back
136	FG	I	Rotation monitor signal input from the spindle motor driver
137	PCK2	O	Bit clock output for EFM playback
138	DVDD	—	Power supply +5V (digital)

Pin No.	Pin Name	I/O	Description
139	DVSS	—	Ground terminal (digital)
140	ATIPSYNC	O	ATIP sync signal output
141	BIDATA	I/O	ATIP demodulator input/output (fixed at “L”)
142	BICLK	I/O	ATIP demodulator input/output (fixed at “L”)
143	WOBBLE	I	ATIP demodulator input/output
144	JITERR	O	Clock jitter suppressor error signal output Not used (open)
145	JITPCO	O	PLL phase frequency comparator output
146	JITLPFI	I	PLL low-pass filter input terminal
147	JITLPFO	O	PLL low-pass filter output terminal
148	JITVCOIN	I	PLL, VCO clock input terminal
149	AVSS	—	Ground terminal (analog)
150	AVDD	—	Power supply +3.3V (analog) for the clock jitter suppressor
151	DIRRS	I	VCO gain control signal input
152	DIRVCO	I	VCO free running oscillation frequency control signal input
153	DIRLPF	O	Loop filter setting terminal
154	AVDD	—	Power supply +3.3V (analog) for the DIR
155	AVSS	—	Ground terminal (analog)
156	DVDD	—	Power supply +5V (digital)
157	DVSS	—	Ground terminal (digital)
158	DIRERR	O	PLL lock data error output
159	DIN1	I	Digital data input from the IC500
160	DIN2	I	Digital data input from the IC101
161, 162	DIN3, DIN4	I	Digital data input Not used (ground)
163	DACCKOUT	O	DAC clock output Not used (open)
164	ENCCKOUT	O	RF processor clock output Not used (open)
165	CDCKOUT	O	CD decoder clock output Not used (open)
166	AUXMCKIN	I	External clock input (fixed at “L”)
167	XTALCK	I	Crystal oscillation circuit input
168	XTAL	O	Crystal oscillation circuit output
169	PDO0	O	Charge pump output
170	VCNT0	I	VCO control voltage input
171	R0	I	VCO bias resistor terminal
172	AVDD	—	Power supply +3.3V (analog) for the clock
173	AVSS	—	Ground terminal (analog)
174	TEST4	I/O	ADCKOUT clock output
175	ROUT	O	DAC output Not used (open)
176	AVDD	—	Power supply +5V (analog) for the internal DAC
177	AVSS	—	Ground terminal (analog)
178	LOUT	O	DAC output Not used (open)
179	DACDATA	O	DAC serial data output Not used (open)
180	DACLK	O	DAC LRCK output Not used (open)
181	DACBCK	O	DAC BCK output Not used (open)
182	DVDD	—	Power supply +3.3V (digital)
183	DVSS	—	Ground terminal (digital)
184	ADCDATA	I	ADC serial data input Not used (fixed at “L”)
185	ADCBCK	O	ADC BCK output Not used (open)
186	ADCLK	O	ADC LRCK output Not used (open)
187	AUXDATA	I	External serial data input Not used (open)
188	AUXBCK	I	External BCK input Not used (fixed at “L”)
189	AUXLRCK	I	External LRCK input Not used (fixed at “L”)

Pin No.	Pin Name	I/O	Description
190	DVDD	—	Power supply +5V (digital)
191	DVSS	—	Ground terminal (digital)
192	ADCSTBY	O	ADC standby signal output
193	AUXTX	I	DIT data input Not used (fixed at “L”)
194	DITOUT	O	DIT data output
195	TEST3	I/O	Used as EXTDACEMP input (fixed at “L”)
196	SBDATA	I/O	Sub-code I/F serial data input/output (fixed at “L”)
197	CLCK	I/O	Sub-code I/F data shift clock input/output (fixed at “L”)
198	SFSY	I/O	Sub-code I/F frame sync signal input/output (fixed at “L”)
199	SBSY	I/O	Sub-code I/F block sync signal input/output (fixed at “L”)
200	ZRAS	O	Row address strobe signal output to the buffer RAM for audio data delay
201	ZCAS	O	Column address strobe signal output to the buffer RAM for audio data delay
202	ZWE	O	Write enable signal output to the buffer RAM for audio data delay
203	ZOE	O	Read enable signal output to the buffer RAM for audio data delay
204 to 207	RA0 to RA3	O	Address signal output to the buffer RAM for audio data delay
208	DVDD	—	Power supply +3.3V (DRAM I/F)

• IC501 HD6433064BA02FV μ COM (CDR Board)

Pin No.	Pin Name	I/O	Description
1	VCL	—	Capacitor connection terminal for the internal power supply
2	XCSCDR	O	Chip select signal output to the IC201
3 to 5	NU	—	Not used (fixed at "H")
6	XRSTRFP	O	Register reset signal output to the IC101
7	XREQI	I	Data request signal from the IC1
8	XRDYO	O	Data ready signal to the IC1
9	XRSTCDR	O	Reset signal to the IC201
10	FWE	I	Flash memory write enable signal input
11	VSS	—	Ground terminal
12	SDATAO(PROM)	O	Serial data output to the IC101 and IC502
13	SDATAO(HOST)	O	Serial data output to the IC1
14	SDATAI(PROM)	I	Serial data input from the IC502
15	SDATAI(HOST)	I	Serial data input from the IC1
16	SCLKO	O	Clock output to the IC101 and IC502
17	SUB_SYNC	I	Sub-code sync signal input from the IC201
18	RSBETA	O	β measurement circuit reset signal output
19, 20	NU	—	Not used (fixed at "H")
21	MIRR/XRC	O	MIRR or RC selection signal output
22	VSS	—	Ground terminal
23	AGCON	O	AGC enable signal output to the IC101
24	XRW/R	O	CD-RW selection signal output to the IC101
25	VRDSW	O	Read laser driver time constant selection switch control signal output to the IC101
26	VWDSW	O	Write laser driver time constant selection switch control signal output to the IC101
27 to 34	D8 to D15	I/O	Data bus with the IC201
35	VCC	—	Power supply (+5V)
36 to 43	A0 to A7	O	Command register selection address signal output to the IC201
44	VSS	—	Ground terminal
45 to 56	A8 to A19	O	Not used (fixed at "H")
57	VSS	—	Ground terminal
58	NU	—	Not used
59	CS	O	Chip select signal output to the IC502
60	XLAT	O	Data latch signal output to the IC101
61	ATIPSYNC	I	ATIP SYNC signal input from the IC201
62	XSTBY	I	Not used (fixed at "H")
63	XREST	I	System reset signal input
64	XP.DOWN	I	Not used
65	VSS	—	Ground terminal
66	EXTAL	I	Ceramic resonator connection terminal
67	XTAL	I	Ceramic resonator connection terminal
68	VCC	—	Power supply (+5V)
69	XAS	O	Not used
70	XRD	O	Data read signal output to the IC201
71	XHWR	O	Data write signal output to the IC201
72	XLWR	O	Not used
73	MD0(H)	I	Mode selector (fixed at "H")
74	MD1(L)	I	Mode selector (fixed at "L")
75	MD2	I	Mode selector (normally fixed at "H")
76	AVCC	—	Power supply (+5V) for the A/D converter
77	AVREF	—	Reference voltage for the A/D converter
78	KEY	I	Key scan signal input

Pin No.	Pin Name	I/O	Description
79	BCENT	I	Center signal input from the IC101
80	PHBETA	I	β signal top level signal input from the IC101
81	BHBETA	I	β signal bottom level signal input from the IC101
82	VREF	I	Reference voltage input terminal
83	MPX	I	Monitor multiplexer signal input from the IC101
84	TMP	I	THERMOUT signal input
85	VWDC2	O	VWDC2 signal output to the optical pick-up
86	AVSS	—	Ground terminal for the A/D converter
87	XINTCDR	I	Interrupt request signal input from the IC201
88	RECD	I	Recorded block detection signal input from the IC101
89	XTAND	I	Tracking failure detection signal input from the IC101
90	SPFG	I	Not used
91	XIN/EXT	I	RS-232C "H" detection signal input
92	VSS	—	Ground terminal
93	SLFG	I	ENCOUT signal input
94	TZC	I	Tracking zero cross detection signal input from the IC101
95	SPFG	I	FG signal input from the motor driver (IC172)
96	XMMUTE	O	Muting signal output to the IC171 and IC172
97	INSW	I	LOAD IN switch (S170) signal input
98	OUTSW	I	LOAD OUT switch (S171) signal input
99	REV	O	Loading motor control signal output to the IC171
100	FWD	O	Loading motor control signal output to the IC171

SECTION 7 EXPLODED VIEWS

NOTE:

- -XX, -X mean standardized parts, so they may have some differences from the original one.
- Items marked "*" are not stocked since they are seldom required for routine service. Some delay should be anticipated when ordering these items.

- The mechanical parts with no reference number in the exploded views are not supplied.
- Accessories are given in the last of this parts list.
- Abbreviation
CND : Canadian model

The components identified by mark Δ or dotted line with mark Δ are critical for safety. Replace only with part number specified.

Les composants identifiés par une marque Δ sont critiques pour la sécurité. Ne les remplacer que par une pièce portant le numéro spécifié.

7-1. Case Section

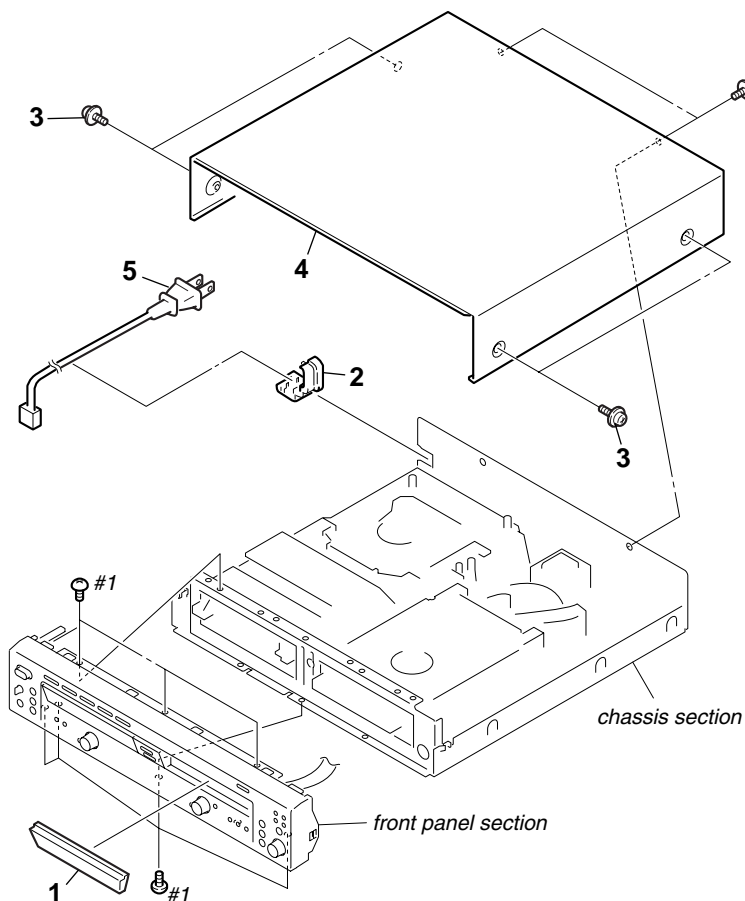

Ref. No.	Part No.	Description	Remarks	Ref. No.	Part No.	Description	Remarks
1	4-246-073-01	PANEL (CDR), LOADING		4	4-231-686-11	CASE (409538)	
* 2	3-703-244-00	BUSHING (2104), CORD		Δ 5	1-783-531-42	CORD, POWER	
3	4-210-291-01	SCREW (CASE 3 TP2)		#1	7-685-646-79	SCREW +BVTP 3X8 TYPE2 IT-3	

7-2. Front Panel Section

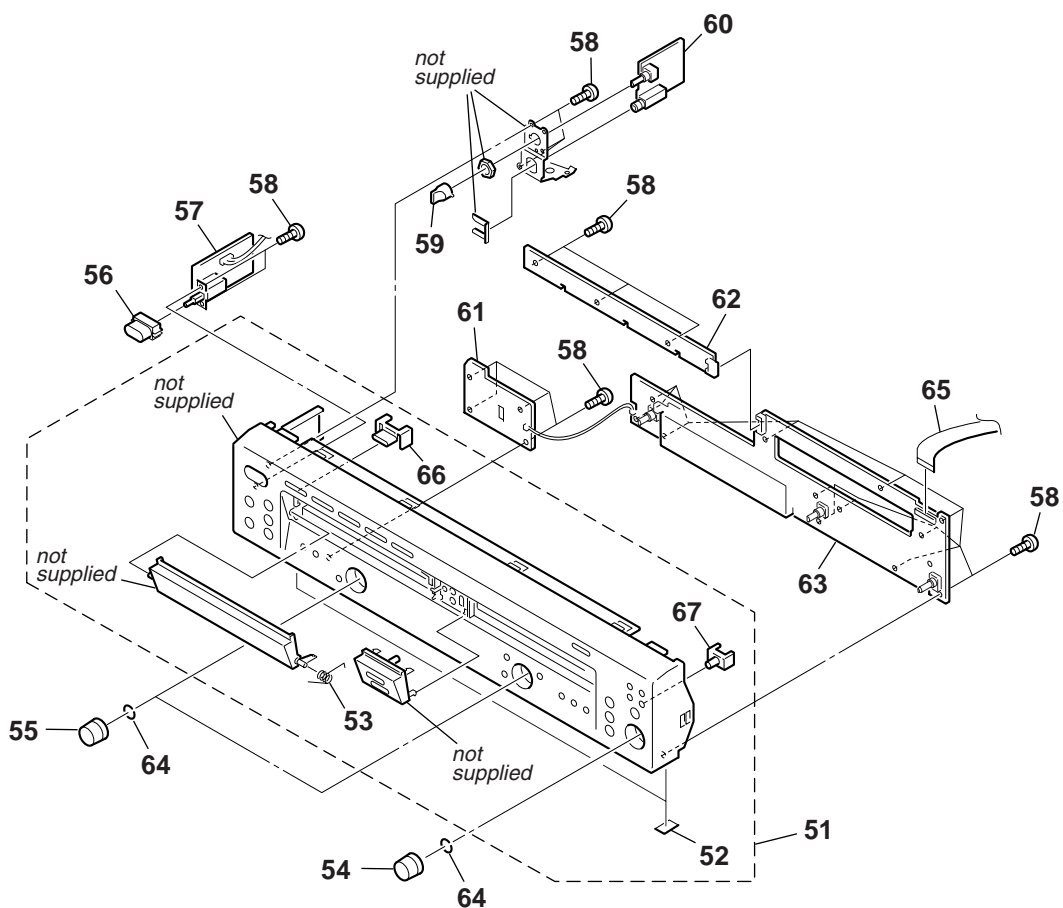

Ref. No.	Part No.	Description	Remarks	Ref. No.	Part No.	Description	Remarks
51	X-4955-524-1	PANEL ASSY, FRONT		60	1-683-868-21	HP BOARD	
52	4-977-358-01	CUSHION		61	1-683-867-21	SW BOARD	
53	4-241-393-01	SPRING, TORSION		62	A-4732-812-A	LED BOARD, COMPLETE	
54	4-238-396-11	KNOB (AMS)		63	A-4732-814-A	DISP BOARD, COMPLETE	
55	4-238-396-01	KNOB (AMS)		64	3-354-981-11	SPRING(SUS),RING	
56	4-231-973-01	BUTTON (POWER)		65	1-823-923-11	WIRE (FLAT TYPE) (21 CORE)	
57	1-683-869-21	POWER BOARD		66	4-238-386-21	BUTTON (OPEN/CLOSE)	
58	4-951-620-01	SCREW (2.6X8), +BVTP		67	4-238-385-01	BUTTON (SBM)	
59	3-931-378-51	KNOB (F10)					

7-3. Chassis Section

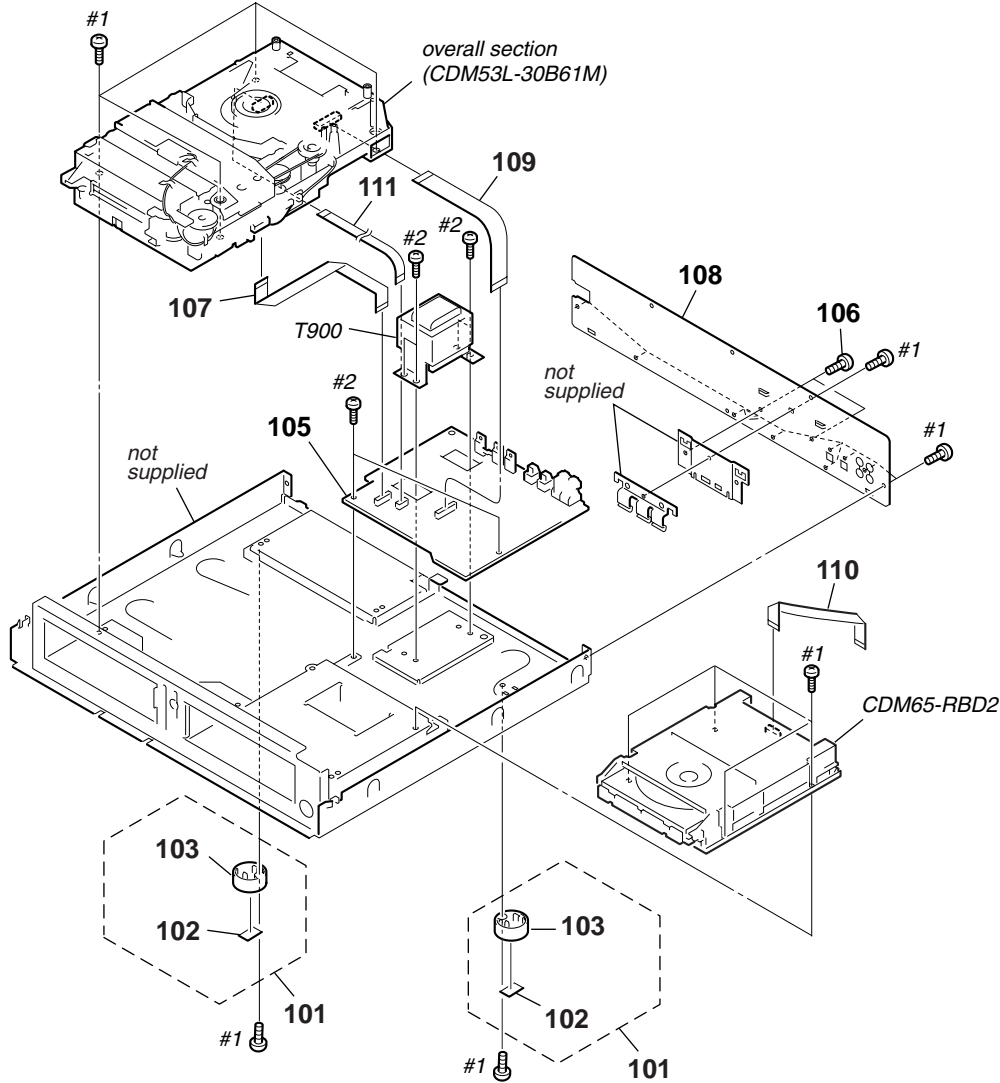

Ref. No.	Part No.	Description	Remarks	Ref. No.	Part No.	Description	Remarks
101	X-4953-448-1	FOOT ASSY		109	1-782-881-11	WIRE(FLAT TYPE) (25CORE)	
102	4-977-358-01	CUSHION		110	1-823-922-11	WIRE(FLAT TYPE) (11CORE)	
103	4-232-237-01	FOOT (DIA. 30)		111	1-782-864-11	WIRE (FLAT TYPE) (9 CORE)	
105	A-4732-811-A	MAIN BOARD, COMPLETE		△T900	1-439-732-11	TRANSFORMER, POWER	
106	3-703-249-01	SCREW, S TIGHT, +PTTWH 3X6		#1	7-685-646-79	SCREW +BVTP 3X8 TYPE2 IT-3	
107	1-823-925-11	WIRE(FLAT TYPE) (17CORE)		#2	7-685-871-01	SCREW +BVTT 3X6 (S)	
108	4-246-074-01	PANEL, BACK (US)					
108	4-246-074-11	PANEL, BACK (CND)					

<p>The components identified by mark △ or dotted line with mark △ are critical for safety. Replace only with part number specified.</p>	<p>Les composants identifiés par une marque △ sont critiques pour la sécurité. Ne les remplacer que par une pièce portant le numéro spécifié.</p>
---	---

7-4. Overall Section (CDM53L-30B61M)

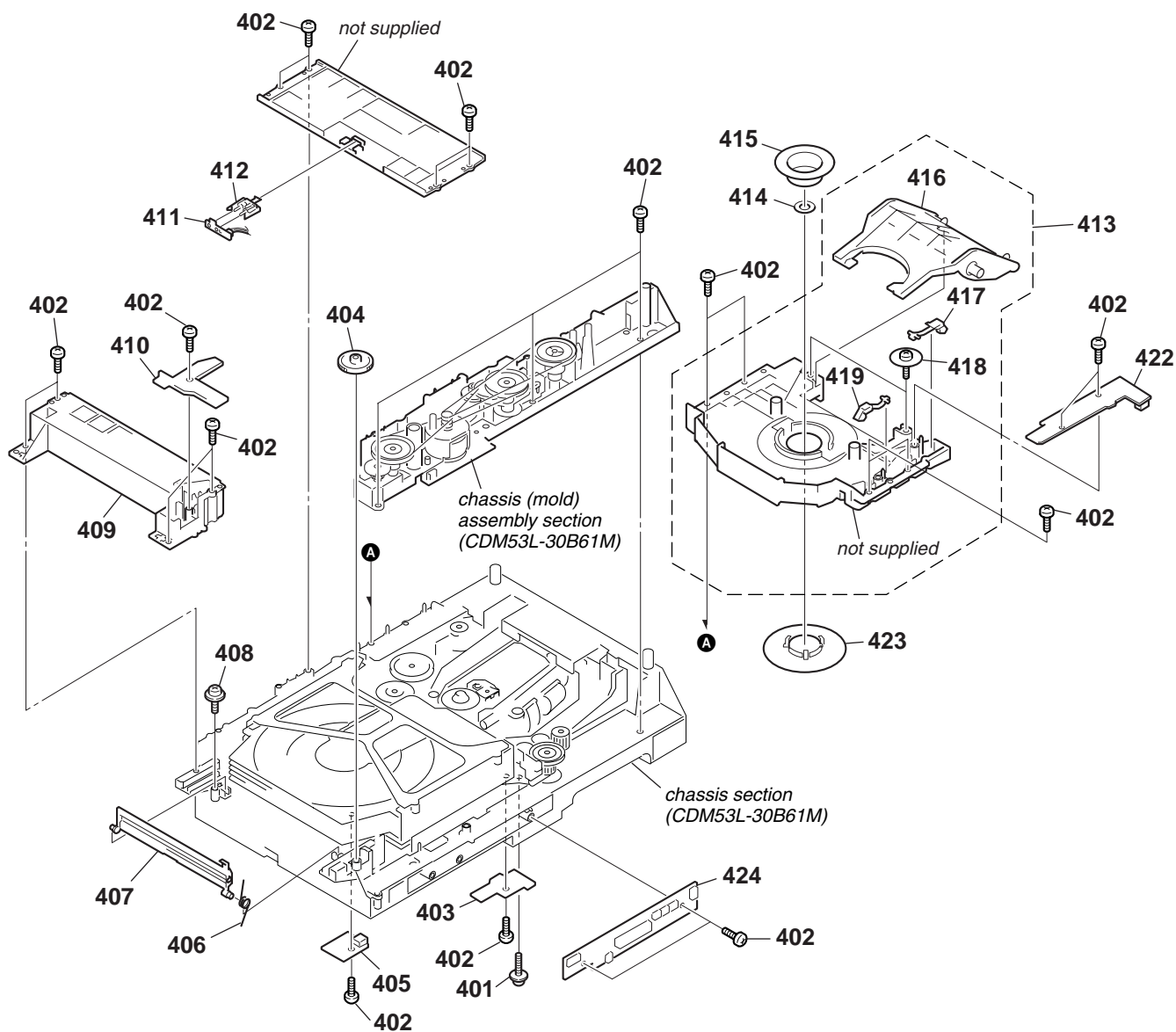

Ref. No.	Part No.	Description	Remarks	Ref. No.	Part No.	Description	Remarks
401	3-341-549-01	SCREW(2.6X12)(DIA.7.5),+PTP WH		412	4-964-461-02	HOLDER (SENSOR)	
402	4-218-253-11	SCREW (M2.6), +BTTP		413	A-4746-928-A	BASE (MAGNET) ASSY, FITTING	
403	1-675-724-11	INIT/COUNT SW BOARD		414	4-228-414-01	BRACKET (YOKE)	
404	4-211-215-01	GEAR (EJECT)		415	4-227-513-01	PULLEY (4SB)	
405	1-675-726-11	SENSOR BOARD		416	4-222-783-01	LEVER (LIFTER)	
406	4-212-676-01	SPRING (LID), TORSION		417	4-221-530-01	LEVER (DETECTION C)	
407	4-221-532-11	LID (DISC)		418	4-985-672-01	SCREW (+PTPWH M2.6), FLOATING	
408	4-933-134-01	SCREW (M2.6), +PTPWH		419	4-221-528-01	LEVER (DETECTION A)	
409	A-4672-909-C	BASE (GUIDE) ASSY, FITTING		422	1-675-723-11	IN SW BOARD	
410	1-675-725-11	OUT SW BOARD		423	X-4952-916-1	PULLEY (FK) ASSY, CHUCKING	
411	1-675-727-11	SENSOR 2 BOARD		424	1-675-722-11	CONNECTOR BOARD	

7-5. Chassis (Mold) Assy Section (CDM53L-30B61M)

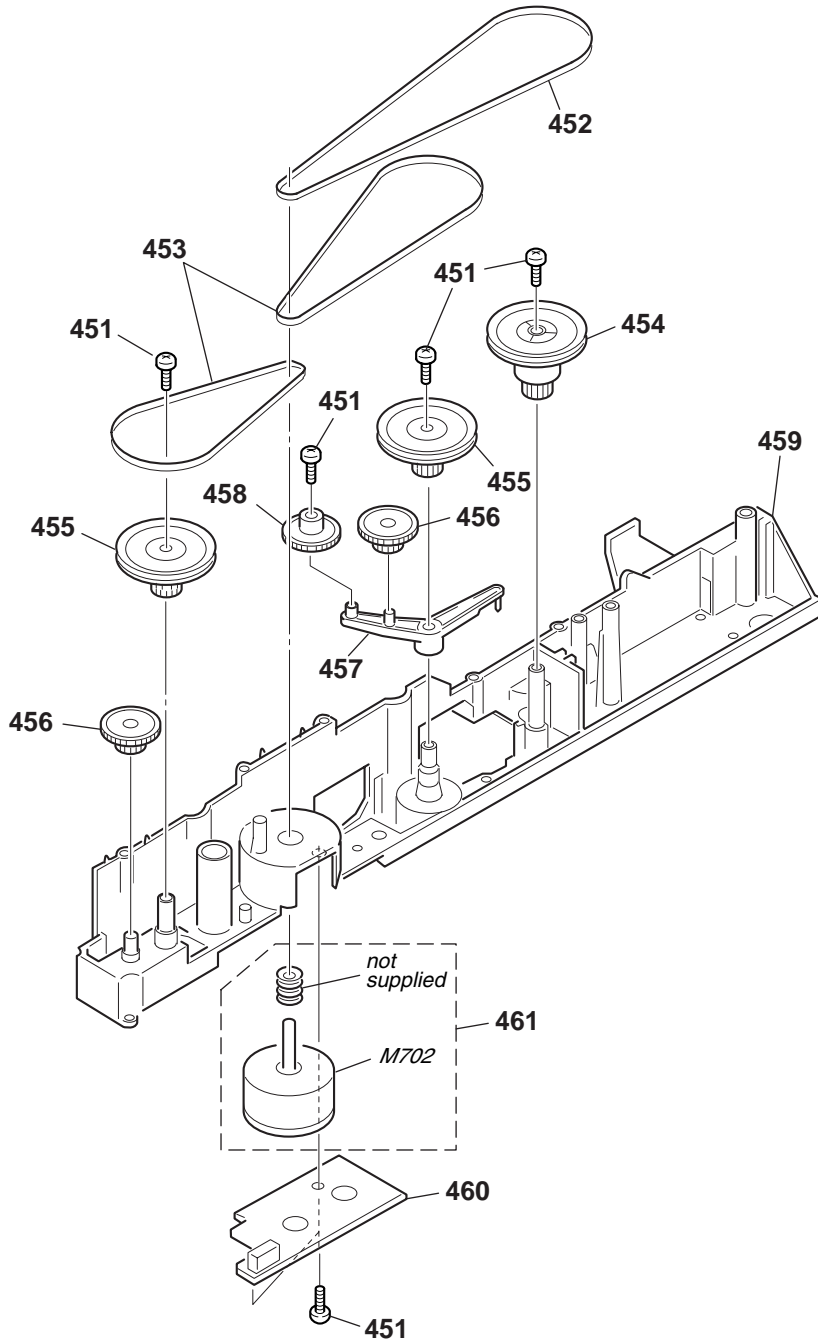

Ref. No.	Part No.	Description	Remarks	Ref. No.	Part No.	Description	Remarks
451	4-218-253-11	SCREW (M2.6), +BTPP		457	4-211-228-01	LEVER (GOOSENECK)	
452	4-211-235-01	BELT (COMMUNICATION)		458	4-214-130-01	GEAR (TRAY)	
453	4-241-745-01	BELT (LOADING 1)		459	4-221-505-11	CHASSIS (MOLD B)	
454	4-211-231-01	PULLEY (MODE)		460	1-675-728-11	LOAD MOTOR BOARD	
455	4-211-214-01	PULLEY (LD)		461	X-4950-342-1	MOTOR (LOADING) ASSY	
456	4-211-232-01	GEAR (LD DECELERATION)		M702	1-541-632-12	MOTOR, DC (LOADING)	

7-6. Chassis Section (CDM53L-30B61M)

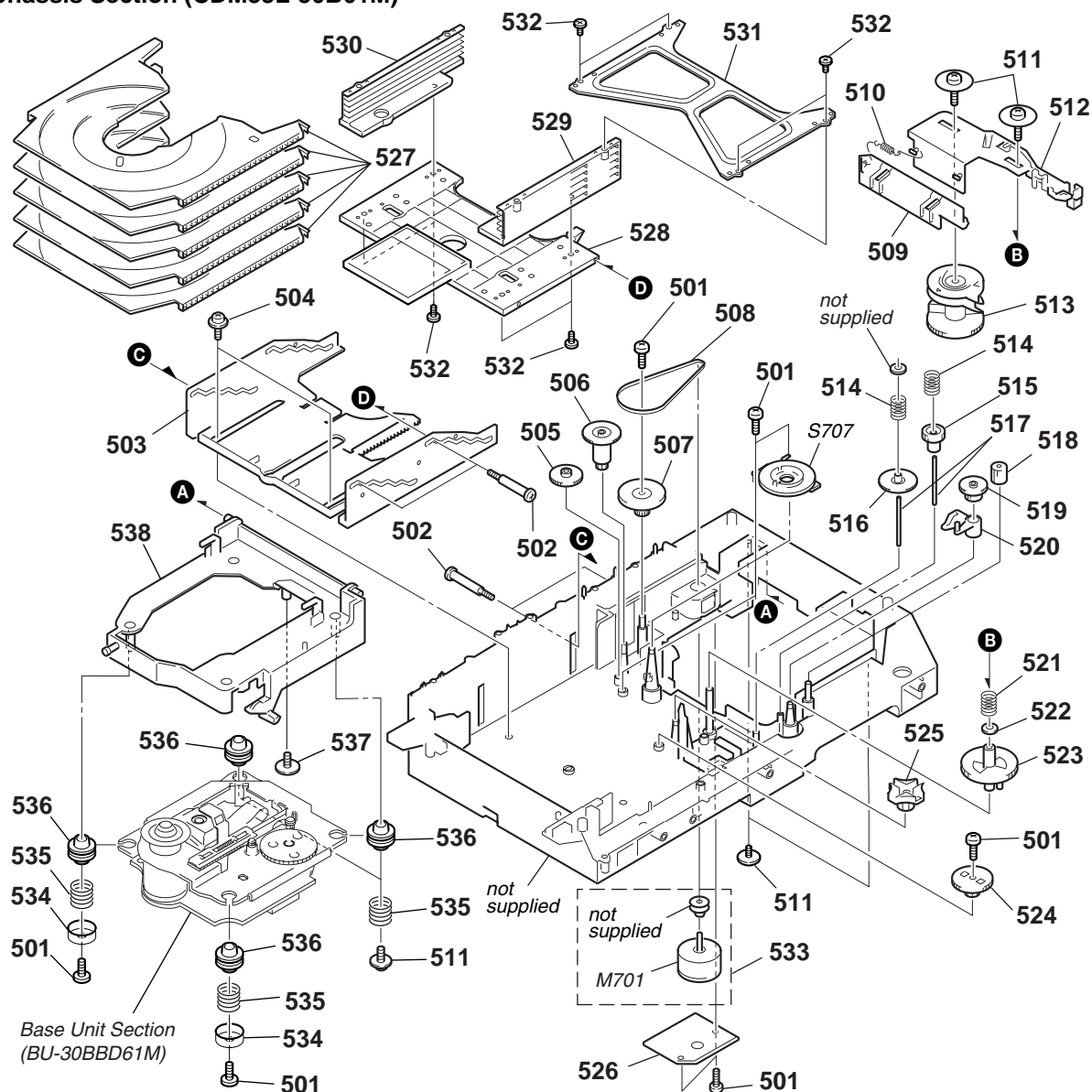

Ref. No.	Part No.	Description	Remarks	Ref. No.	Part No.	Description	Remarks
501	4-218-253-11	SCREW (M2.6), +BTTP		521	4-216-879-01	SPRING (GEAR), COMPRESSION	
502	4-211-244-01	SCREW, STEP		522	3-701-446-21	WASHER	
503	4-211-223-01	SLIDER (U/D)		523	4-211-218-01	GEAR (GEAR A)	
504	4-933-134-01	SCREW (M2.6), +PTPWH		524	4-211-220-01	GEAR (U/D SLIDER)	
505	4-211-215-01	GEAR (EJECT)		525	4-211-219-01	GEAR (GEAR B)	
506	4-211-232-01	GEAR (MODE DECELERATION)		526	1-675-729-11	CLAMP MOTOR BOARD	
507	4-211-214-01	PULLEY (LD)		527	4-211-212-51	TRAY (SUB)	
508	4-211-237-01	BELT (MODE)		528	4-221-504-01	BASE (STOCKER), FITTING	
509	4-212-677-01	SLIDER (SHUTTER)		529	4-211-211-01	STOCKER (R)	
510	4-212-678-01	SPRING (SHUTTER), TENSION		530	4-211-210-01	STOCKER (L)	
511	4-985-672-01	SCREW (+PTPWH M2.6), FLOATING		531	4-211-234-01	BRACKET (STOCKER T)	
512	4-211-233-01	SLIDER (SELECTION)		532	4-218-253-21	SCREW (M2.6), +BTTP	
513	4-211-230-01	GEAR (CHUCKING)		533	X-4950-341-1	MOTOR (CLAMP) ASSY	
514	4-211-245-01	SPRING, COMPRESSION		534	4-231-151-01	STOPPER (BU)	
515	4-211-221-01	GEAR (LD MOVABLE)		535	4-227-045-11	SPRING (INSULATOR), COIL	
516	4-211-217-01	GEAR (SELECTION)		536	4-240-820-01	INSULATOR (B)(BU-30B)	
517	4-211-242-11	SHAFT (SELECTION GEAR)		537	4-227-899-01	SCREW (DIA.12), FROATING	
518	4-211-240-01	GEAR (LD DECELERATION B)		538	X-4954-297-2	HOLDER (BU30) ASSY	
519	4-211-216-01	GEAR (RELAY)		M701	1-541-632-12	MOTOR, DC (ELEVATOR)	
520	4-211-241-01	LEVER (SELECTION)		S707	1-418-045-01	ENCODER, ROTARY	

7-7. Base Unit Section (BU-30BBD61M)

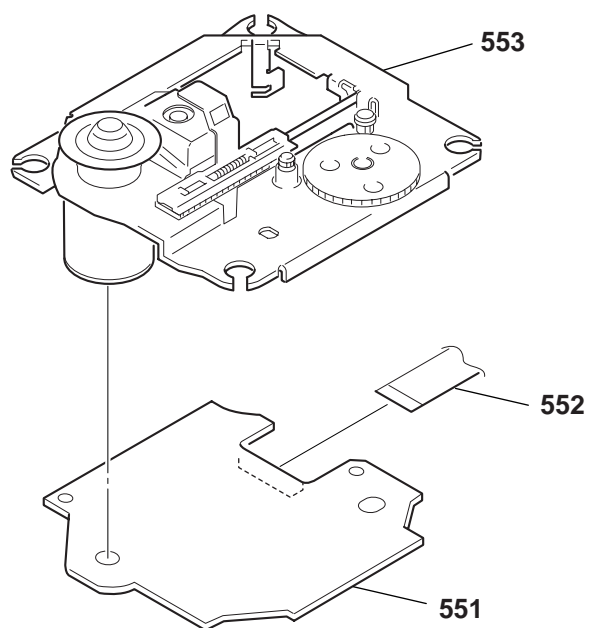

<u>Ref. No.</u>	<u>Part No.</u>	<u>Description</u>	<u>Remarks</u>	<u>Ref. No.</u>	<u>Part No.</u>	<u>Description</u>	<u>Remarks</u>
551	A-4732-100-A	BD BOARD, COMPLETE		△ 553	A-4735-885-A	BU-30B ASSY	
552	1-782-817-11	WIRE (FLAT TYPE)(16 CORE)					

The components identified by mark △ or dotted line with mark △ are critical for safety. Replace only with part number specified.

Les composants identifiés par une marque △ sont critiques pour la sécurité. Ne les remplacer que par une pièce portant le numéro spécifié.

7-8. CDM65-RBD2

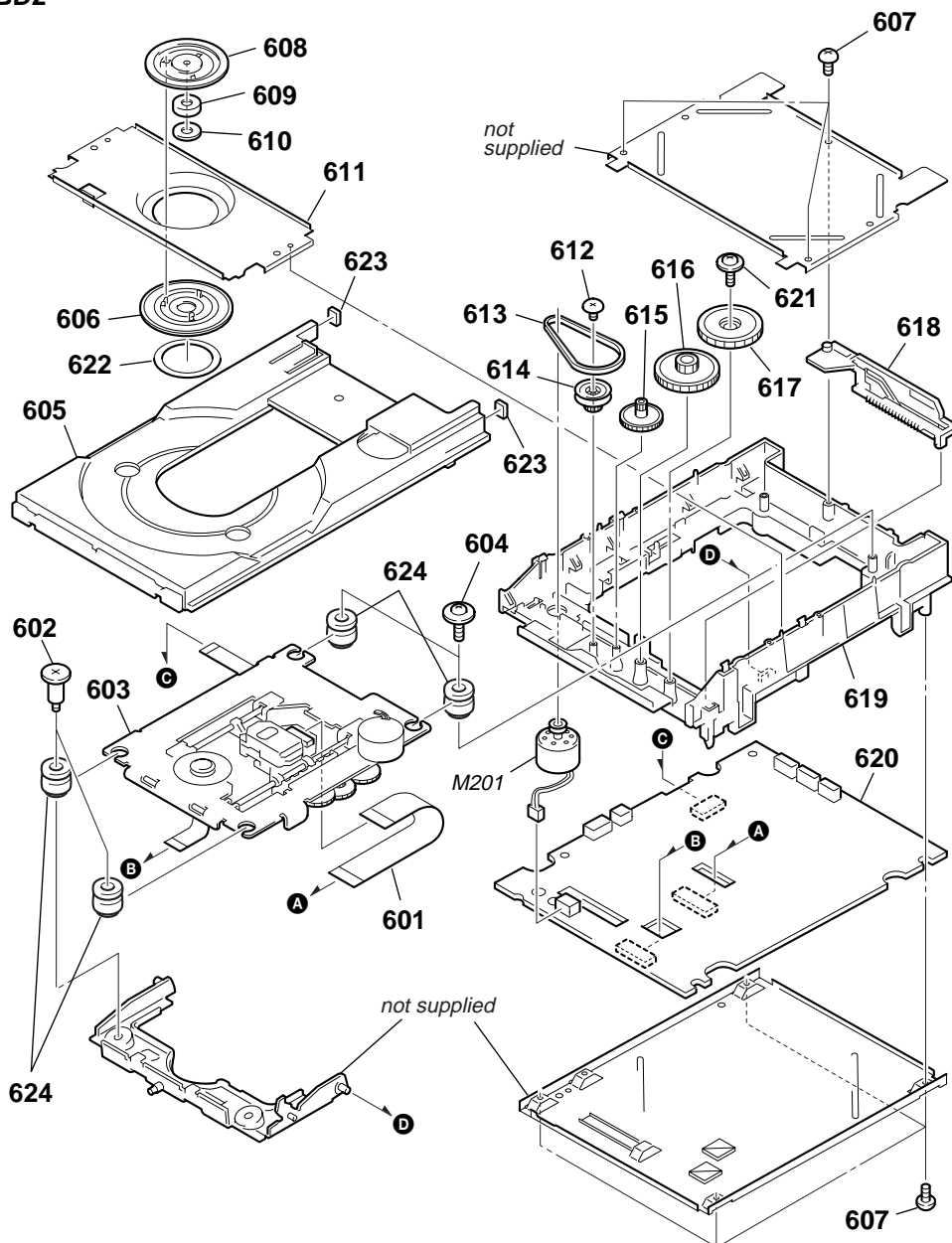

Ref. No.	Part No.	Description	Remarks	Ref. No.	Part No.	Description	Remarks
601	1-823-651-11	CABLE, FLEXIBLE FLAT (32 CORE)		613	4-999-537-01	BELT (LOADING)	
602	4-237-168-01	SCREW, STEP		614	4-237-176-02	PULLEY (CG)	
△ 603	8-583-104-01	OPTICAL PICK-UP (KRM-220CAA)		615	4-237-177-02	GEAR (A)	
604	4-237-167-01	SCREW (2X9) (G WITH),+P TAPPIN		616	4-237-178-02	GEAR (B)	
605	4-237-181-01	TRAY		617	4-237-179-02	GEAR (C)	
606	4-237-174-01	PULLEY (MAG)		618	4-237-180-01	CAM (CH)	
607	4-951-620-01	SCREW (2.6X8), +BVTP		619	4-237-182-01	CHASSIS	
608	4-240-988-02	PULLEY (UPPER), PRESS		620	A-4732-808-A	CDR BOARD, COMPLETE	
* 609	1-452-958-11	MAGNET (CHUCKING)		621	3-341-549-01	SCREW(2.6X8)(DIA.7.5),+ PTP WH	
* 610	4-974-710-11	YOKE, PULLEY		622	4-240-987-01	SHEET (DR)	
611	4-237-172-01	HOLDER (MG)		623	4-232-682-01	CUSHION (66)	
612	4-974-711-01	SCREW (2X5)(P TYIGHT),(+)PTTWH		624	2-166-060-01	INSULATOR (MAIN)	
				M201	A-4735-557-A	MOTOR ASSY (LOADING)	

<p>The components identified by mark △ or dotted line with mark △ are critical for safety. Replace only with part number specified.</p>	<p>Les composants identifiés par une marque △ sont critiques pour la sécurité. Ne les remplacer que par une pièce portant le numéro spécifié.</p>
---	---

SECTION 8
ELECTRICAL PARTS LIST

NOTE:

- Due to standardization, replacements in the parts list may be different from the parts specified in the diagrams or the components used on the set.
- -XX, -X mean standardized parts, so they may have some difference from the original one.
- Items marked “**” are not stocked since they are seldom required for routine service. Some delay should be anticipated when ordering these items.
- CAPACITORS:
uF: μ F

- RESISTORS
All resistors are in ohms.
METAL: metal-film resistor
METAL OXIDE: Metal Oxide-film resistor
F: nonflammable
- COILS
uH: μ H
- SEMICONDUCTORS
In each case, u: μ , for example:
uA...: μ A... , uPA... , μ PA... ,
uPB... , μ PB... , uPC... , μ PC... ,
uPD... , μ PD...

- Abbreviation
CND : Canadian model

When indicating parts by reference number, please include the board name.

The components identified by mark Δ or dotted line with mark Δ are critical for safety. Replace only with part number specified.

Les composants identifiés par une marque Δ sont critiques pour la sécurité. Ne les remplacer que par une pièce portant le numéro spécifié.

Ref. No.	Part No.	Description	Remarks
	A-4732-100-A	BD BOARD, COMPLETE *****	
		< CAPACITOR >	
C101	1-164-315-11	CERAMIC CHIP 470PF	5.00% 50V
C102	1-107-826-11	CERAMIC CHIP 0.1uF	10.00% 16V
C103	1-164-315-11	CERAMIC CHIP 470PF	5.00% 50V
C104	1-162-967-11	CERAMIC CHIP 0.0033uF	10% 50V
C107	1-162-921-11	CERAMIC CHIP 33PF	5% 50V
C108	1-164-360-11	CERAMIC CHIP 0.1uF	16V
C109	1-164-360-11	CERAMIC CHIP 0.1uF	16V
C110	1-107-826-11	CERAMIC CHIP 0.1uF	10.00% 16V
C111	1-126-607-11	ELECT CHIP 47uF	20% 4V
C112	1-164-360-11	CERAMIC CHIP 0.1uF	16V
C113	1-128-995-21	ELECT CHIP 100uF	20% 10V
C114	1-162-964-11	CERAMIC CHIP 0.001uF	10% 50V
C115	1-128-995-21	ELECT CHIP 100uF	20% 10V
C116	1-107-826-11	CERAMIC CHIP 0.1uF	10.00% 16V
C117	1-164-360-11	CERAMIC CHIP 0.1uF	16V
C118	1-115-156-11	CERAMIC CHIP 1uF	10V
C119	1-115-156-11	CERAMIC CHIP 1uF	10V
C121	1-164-360-11	CERAMIC CHIP 0.1uF	16V
C131	1-110-563-11	CERAMIC CHIP 0.068uF	10.00% 16V
C132	1-164-227-11	CERAMIC CHIP 0.022uF	10% 25V
C133	1-125-838-11	CERAMIC CHIP 2.2uF	10% 6.3V
C150	1-128-394-11	ELECT CHIP 220uF	20% 10V
C151	1-164-360-11	CERAMIC CHIP 0.1uF	16V
C152	1-164-360-11	CERAMIC CHIP 0.1uF	16V
C153	1-164-360-11	CERAMIC CHIP 0.1uF	16V
C156	1-162-968-11	CERAMIC CHIP 0.0047uF	10% 50V
C157	1-115-416-11	CERAMIC CHIP 0.001uF	5.00% 25V
C158	1-162-970-11	CERAMIC CHIP 0.01uF	10% 25V
C159	1-162-927-11	CERAMIC CHIP 100PF	5% 50V
C160	1-107-826-11	CERAMIC CHIP 0.1uF	10.00% 16V
C161	1-107-826-11	CERAMIC CHIP 0.1uF	10.00% 16V
C163	1-107-826-11	CERAMIC CHIP 0.1uF	10.00% 16V
C164	1-107-826-11	CERAMIC CHIP 0.1uF	10.00% 16V
C165	1-107-826-11	CERAMIC CHIP 0.1uF	10.00% 16V
C169	1-128-394-11	ELECT CHIP 220uF	20% 10V
C202	1-164-360-11	CERAMIC CHIP 0.1uF	16V
C203	1-162-964-11	CERAMIC CHIP 0.001uF	10% 50V
C205	1-164-360-11	CERAMIC CHIP 0.1uF	16V
C208	1-164-360-11	CERAMIC CHIP 0.1uF	16V
C209	1-164-230-11	CERAMIC CHIP 220PF	5.00% 50V

Ref. No.	Part No.	Description	Remarks
C211	1-117-863-11	CERAMIC CHIP 0.47uF	10.00% 6.3V
C212	1-164-315-11	CERAMIC CHIP 470PF	5.00% 50V
C213	1-115-414-11	CERAMIC CHIP 820PF	5.00% 25V
C215	1-117-863-11	CERAMIC CHIP 0.47uF	10.00% 6.3V
C216	1-162-970-11	CERAMIC CHIP 0.01uF	10% 25V
C222	1-115-156-11	CERAMIC CHIP 1uF	10V
C224	1-115-156-11	CERAMIC CHIP 1uF	10V
C226	1-126-607-11	ELECT CHIP 47uF	20% 4V
C227	1-164-360-11	CERAMIC CHIP 0.1uF	16V
C228	1-115-156-11	CERAMIC CHIP 1uF	10V
C229	1-164-360-11	CERAMIC CHIP 0.1uF	16V
C230	1-164-360-11	CERAMIC CHIP 0.1uF	16V
C231	1-128-394-11	ELECT CHIP 220uF	20% 10V
C248	1-125-838-11	CERAMIC CHIP 2.2uF	10% 6.3V
C249	1-164-360-11	CERAMIC CHIP 0.1uF	16V
C250	1-164-360-11	CERAMIC CHIP 0.1uF	16V
C251	1-164-360-11	CERAMIC CHIP 0.1uF	16V
C253	1-164-360-11	CERAMIC CHIP 0.1uF	16V
C254	1-162-913-11	CERAMIC CHIP 8PF	0.50PF 50V
C255	1-164-360-11	CERAMIC CHIP 0.1uF	16V
C256	1-164-360-11	CERAMIC CHIP 0.1uF	16V
C257	1-128-934-91	CERAMIC CHIP 0.33uF	20% 10V
C258	1-162-913-11	CERAMIC CHIP 8PF	0.50PF 50V
C259	1-164-360-11	CERAMIC CHIP 0.1uF	16V
C260	1-131-998-21	ELECT CHIP 82uF	20% 6.3V
C266	1-164-360-11	CERAMIC CHIP 0.1uF	16V
C270	1-162-960-11	CERAMIC CHIP 220PF	10% 50V
C271	1-162-970-11	CERAMIC CHIP 0.01uF	10% 25V
C273	1-162-960-11	CERAMIC CHIP 220PF	10% 50V
C274	1-162-970-11	CERAMIC CHIP 0.01uF	10% 25V
C277	1-216-864-11	METAL CHIP 0	5% 1/10W
C292	1-164-360-11	CERAMIC CHIP 0.1uF	16V
C301	1-115-414-11	CERAMIC CHIP 820PF	5.00% 25V
C302	1-162-966-11	CERAMIC CHIP 0.0022uF	10% 50V
C303	1-164-360-11	CERAMIC CHIP 0.1uF	16V
C304	1-125-838-11	CERAMIC CHIP 2.2uF	10% 6.3V
C305	1-162-970-11	CERAMIC CHIP 0.01uF	10% 25V
C307	1-164-360-11	CERAMIC CHIP 0.1uF	16V
C310	1-164-360-11	CERAMIC CHIP 0.1uF	16V
		< CONNECTOR >	
CN101	1-794-424-11	CONNECTOR, FCC/FPC 16P	
CN103	1-784-875-21	CONNECTOR, FFC(LIF(NON-ZIF))25P	
CN105	1-784-861-21	CONNECTOR, FFC(LIF(NON-ZIF))9P	

Ref. No.	Part No.	Description	Remarks	Ref. No.	Part No.	Description	Remarks
		< FERRITE BEAD >		R166	1-216-864-11	METAL CHIP	0 5% 1/10W
FB101	1-216-295-91	SHORT CHIP	0	R167	1-216-864-11	METAL CHIP	0 5% 1/10W
FB102	1-216-864-11	METAL CHIP	0 5%	R168	1-216-864-11	METAL CHIP	0 5% 1/10W
FB103	1-216-864-11	METAL CHIP	0 5%	R169	1-216-864-11	METAL CHIP	0 5% 1/10W
FB104	1-216-864-11	METAL CHIP	0 5%	R199	1-216-864-11	METAL CHIP	0 5% 1/10W
* FB161	1-469-670-21	FERRITE	0uH	R201	1-216-839-11	METAL CHIP	33K 5% 1/10W
FB201	1-216-295-91	SHORT CHIP	0	R202	1-216-833-11	METAL CHIP	10K 5% 1/10W
* FB202	1-469-670-21	FERRITE	0uH	R203	1-216-845-11	METAL CHIP	100K 5% 1/10W
FB203	1-500-283-11	FERRITE	0uH	R204	1-216-833-11	METAL CHIP	10K 5% 1/10W
FB291	1-216-864-11	METAL CHIP	0 5%	R205	1-216-823-11	METAL CHIP	1.5K 5% 1/10W
FB351	1-216-864-11	METAL CHIP	0 5%	R206	1-216-850-11	METAL CHIP	270K 5% 1/10W
		< IC >		R207	1-216-853-11	METAL CHIP	470K 5% 1/10W
IC101	8-752-408-73	IC CXD3068Q		R208	1-216-811-11	METAL CHIP	150 5% 1/10W
IC102	8-759-713-71	IC AN41050		R216	1-216-857-11	METAL CHIP	1M 5% 1/10W
IC103	8-752-106-21	IC CXA2647N-T4		R218	1-216-821-11	METAL CHIP	1K 5% 1/10W
IC104	6-704-150-01	IC CXD9717R-008		R219	1-216-821-11	METAL CHIP	1K 5% 1/10W
IC105	8-759-833-99	IC TC74HC4052AFT(EL)		R220	1-216-821-11	METAL CHIP	1K 5% 1/10W
IC122	6-701-808-01	IC BA33C25FP-E2		R221	1-216-809-11	METAL CHIP	100 5% 1/10W
		< JUMPER RESISTOR >		R222	1-216-809-11	METAL CHIP	100 5% 1/10W
JR2	1-216-864-11	METAL CHIP	0 5%	R223	1-216-809-11	METAL CHIP	100 5% 1/10W
		< COIL >		R224	1-216-809-11	METAL CHIP	100 5% 1/10W
L163	1-412-967-31	INDUCTOR	0.1uH	R225	1-216-809-11	METAL CHIP	100 5% 1/10W
		< TRANSISTOR >		R226	1-216-809-11	METAL CHIP	100 5% 1/10W
Q101	8-729-046-90	TRANSISTOR	2SB970-(TX).S0	R227	1-216-809-11	METAL CHIP	100 5% 1/10W
		< RESISTOR >		R228	1-216-809-11	METAL CHIP	100 5% 1/10W
R101	1-216-864-11	METAL CHIP	0 5%	R229	1-216-809-11	METAL CHIP	100 5% 1/10W
R102	1-216-835-11	METAL CHIP	15K 5%	R230	1-216-811-11	METAL CHIP	150 5% 1/10W
R103	1-216-845-11	METAL CHIP	100K 5%	R231	1-216-815-11	METAL CHIP	330 5% 1/10W
R104	1-216-835-11	METAL CHIP	15K 5%	R232	1-216-815-11	METAL CHIP	330 5% 1/10W
R105	1-216-821-11	METAL CHIP	1K 5%	R233	1-216-815-11	METAL CHIP	330 5% 1/10W
R111	1-216-847-11	METAL CHIP	150K 5%	R249	1-216-818-11	METAL CHIP	560 5% 1/10W
R113	1-218-701-11	METAL CHIP	2.4K 5%	R250	1-216-813-11	METAL CHIP	220 5% 1/10W
R114	1-216-852-11	METAL CHIP	390K 5%	R251	1-216-813-11	METAL CHIP	220 5% 1/10W
R115	1-216-839-11	METAL CHIP	33K 5%	R252	1-216-833-11	METAL CHIP	10K 5% 1/10W
R116	1-216-839-11	METAL CHIP	33K 5%	R253	1-216-813-11	METAL CHIP	220 5% 1/10W
R117	1-216-846-11	METAL CHIP	120K 5%	R255	1-216-809-11	METAL CHIP	100 5% 1/10W
R118	1-216-833-11	METAL CHIP	10K 5%	R257	1-216-809-11	METAL CHIP	100 5% 1/10W
R120	1-216-846-11	METAL CHIP	120K 5%	R259	1-216-809-11	METAL CHIP	100 5% 1/10W
R122	1-216-845-11	METAL CHIP	100K 5%	R260	1-216-821-11	METAL CHIP	1K 5% 1/10W
R123	1-216-791-11	METAL CHIP	3.3 5%	R271	1-216-833-11	METAL CHIP	10K 5% 1/10W
R125	1-216-840-11	METAL CHIP	39K 5%	R272	1-216-829-11	METAL CHIP	4.7K 5% 1/10W
R126	1-216-840-11	METAL CHIP	39K 5%	R275	1-216-833-11	METAL CHIP	10K 5% 1/10W
R131	1-216-843-11	METAL CHIP	68K 5%	R276	1-216-809-11	METAL CHIP	100 5% 1/10W
R132	1-216-851-11	METAL CHIP	330K 5%	R279	1-216-809-11	METAL CHIP	100 5% 1/10W
R133	1-216-825-11	METAL CHIP	2.2K 5%	R291	1-216-864-11	METAL CHIP	0 5% 1/10W
R151	1-216-833-11	METAL CHIP	10K 5%	R301	1-216-847-11	METAL CHIP	150K 5% 1/10W
R152	1-216-837-11	METAL CHIP	22K 5%	R302	1-216-842-11	METAL CHIP	56K 5% 1/10W
R155	1-216-840-11	METAL CHIP	39K 5%	R304	1-216-809-11	METAL CHIP	100 5% 1/10W
R157	1-216-864-11	METAL CHIP	0 5%	R305	1-216-845-11	METAL CHIP	100K 5% 1/10W
R158	1-216-821-11	METAL CHIP	1K 5%	R308	1-500-283-11	FERRITE	0uH
				R309	1-500-283-11	FERRITE	0uH
				R312	1-216-864-11	METAL CHIP	0 5% 1/10W
				R313	1-216-864-11	METAL CHIP	0 5% 1/10W
				R314	1-216-864-11	METAL CHIP	0 5% 1/10W
				R315	1-216-864-11	METAL CHIP	0 5% 1/10W
				R318	1-216-864-11	METAL CHIP	0 5% 1/10W
				R320	1-216-864-11	METAL CHIP	0 5% 1/10W

RCD-W500C



Ref. No.	Part No.	Description	Remarks
		< VARIABLE RESISTOR >	
RV101	1-223-997-21	RES, CARBON ADJ VAR 47K	
		< VIBRATOR >	
X201	1-767-518-11	VIBRATOR, CRYSTAL (33.8688MHz)	

	A-4732-808-A	CDR BOARD, COMPLETE	

		< CAPACITOR >	
C101	1-162-964-11	CERAMIC CHIP 0.001uF	10% 50V
C102	1-162-970-11	CERAMIC CHIP 0.01uF	10% 25V
C103	1-162-927-11	CERAMIC CHIP 100PF	5% 50V
C104	1-162-927-11	CERAMIC CHIP 100PF	5% 50V
C105	1-162-927-11	CERAMIC CHIP 100PF	5% 50V
C106	1-107-826-11	CERAMIC CHIP 0.1uF	10.00% 16V
C107	1-107-826-11	CERAMIC CHIP 0.1uF	10.00% 16V
C108	1-107-826-11	CERAMIC CHIP 0.1uF	10.00% 16V
C109	1-162-927-11	CERAMIC CHIP 100PF	5% 50V
C110	1-107-826-11	CERAMIC CHIP 0.1uF	10.00% 16V
C111	1-107-826-11	CERAMIC CHIP 0.1uF	10.00% 16V
C112	1-162-927-11	CERAMIC CHIP 100PF	5% 50V
C113	1-162-927-11	CERAMIC CHIP 100PF	5% 50V
C114	1-164-230-11	CERAMIC CHIP 220PF	5.00% 50V
C115	1-164-230-11	CERAMIC CHIP 220PF	5.00% 50V
C116	1-107-826-11	CERAMIC CHIP 0.1uF	10.00% 16V
C117	1-125-891-11	CERAMIC CHIP 0.47uF	10.00% 10V
C118	1-107-826-11	CERAMIC CHIP 0.1uF	10.00% 16V
C119	1-107-826-11	CERAMIC CHIP 0.1uF	10.00% 16V
C120	1-127-760-11	CERAMIC CHIP 4.7uF	10% 6.3V
C121	1-126-392-11	ELECT CHIP 100uF	20.00% 6.3V
C122	1-162-963-11	CERAMIC CHIP 680PF	10% 50V
C123	1-162-968-11	CERAMIC CHIP 0.0047uF	10% 50V
C124	1-162-968-11	CERAMIC CHIP 0.0047uF	10% 50V
C125	1-128-934-91	CERAMIC CHIP 0.33uF	20% 10V
C126	1-162-966-11	CERAMIC CHIP 0.0022uF	10% 50V
C128	1-125-891-11	CERAMIC CHIP 0.47uF	10.00% 10V
C129	1-162-970-11	CERAMIC CHIP 0.01uF	10% 25V
C130	1-164-156-11	CERAMIC CHIP 0.1uF	25V
C131	1-164-156-11	CERAMIC CHIP 0.1uF	25V
C132	1-164-156-11	CERAMIC CHIP 0.1uF	25V
C133	1-164-156-11	CERAMIC CHIP 0.1uF	25V
C134	1-164-156-11	CERAMIC CHIP 0.1uF	25V
C135	1-162-959-11	CERAMIC CHIP 330PF	5% 50V
C136	1-126-391-11	ELECT CHIP 47uF	20.00% 6.3V
C137	1-107-826-11	CERAMIC CHIP 0.1uF	10.00% 16V
C138	1-125-837-91	CERAMIC CHIP 1uF	10% 6.3V
C139	1-107-826-11	CERAMIC CHIP 0.1uF	10.00% 16V
C140	1-126-390-11	ELECT CHIP 22uF	20.00% 6.3V
C141	1-107-826-11	CERAMIC CHIP 0.1uF	10.00% 16V
C142	1-162-964-11	CERAMIC CHIP 0.001uF	10% 50V
C143	1-125-837-91	CERAMIC CHIP 1uF	10% 6.3V
C144	1-128-934-91	CERAMIC CHIP 0.33uF	20% 10V
C145	1-128-934-91	CERAMIC CHIP 0.33uF	20% 10V
C146	1-128-934-91	CERAMIC CHIP 0.33uF	20% 10V
C150	1-164-156-11	CERAMIC CHIP 0.1uF	25V

Ref. No.	Part No.	Description	Remarks
C151	1-164-156-11	CERAMIC CHIP 0.1uF	25V
C154	1-164-156-11	CERAMIC CHIP 0.1uF	25V
C155	1-107-826-11	CERAMIC CHIP 0.1uF	10.00% 16V
C157	1-126-390-11	ELECT CHIP 22uF	20.00% 6.3V
C158	1-126-390-11	ELECT CHIP 22uF	20.00% 6.3V
C160	1-162-970-11	CERAMIC CHIP 0.01uF	10% 25V
C178	1-162-968-11	CERAMIC CHIP 0.0047uF	10% 50V
C179	1-164-156-11	CERAMIC CHIP 0.1uF	25V
C180	1-126-395-11	ELECT 22uF	20% 16V
C181	1-127-573-11	CERAMIC CHIP 1uF	10% 16V
C182	1-127-573-11	CERAMIC CHIP 1uF	10% 16V
C183	1-127-573-11	CERAMIC CHIP 1uF	10% 16V
C184	1-126-395-11	ELECT 22uF	20% 16V
C185	1-164-156-11	CERAMIC CHIP 0.1uF	25V
C186	1-107-826-11	CERAMIC CHIP 0.1uF	10.00% 16V
C187	1-107-826-11	CERAMIC CHIP 0.1uF	10.00% 16V
C188	1-162-970-11	CERAMIC CHIP 0.01uF	10% 25V
C189	1-162-970-11	CERAMIC CHIP 0.01uF	10% 25V
C190	1-162-970-11	CERAMIC CHIP 0.01uF	10% 25V
C191	1-162-964-11	CERAMIC CHIP 0.001uF	10% 50V
C192	1-162-964-11	CERAMIC CHIP 0.001uF	10% 50V
C193	1-164-156-11	CERAMIC CHIP 0.1uF	25V
C194	1-126-395-11	ELECT 22uF	20% 16V
C200	1-126-390-11	ELECT CHIP 22uF	20.00% 6.3V
C201	1-164-156-11	CERAMIC CHIP 0.1uF	25V
C202	1-126-392-11	ELECT CHIP 100uF	20.00% 6.3V
C203	1-164-156-11	CERAMIC CHIP 0.1uF	25V
C204	1-107-826-11	CERAMIC CHIP 0.1uF	10.00% 16V
C205	1-126-391-11	ELECT CHIP 47uF	20.00% 6.3V
C206	1-164-156-11	CERAMIC CHIP 0.1uF	25V
C207	1-107-826-11	CERAMIC CHIP 0.1uF	10.00% 16V
C208	1-107-826-11	CERAMIC CHIP 0.1uF	10.00% 16V
C209	1-164-156-11	CERAMIC CHIP 0.1uF	25V
C210	1-126-392-11	ELECT CHIP 100uF	20.00% 6.3V
C212	1-126-390-11	ELECT CHIP 22uF	20.00% 6.3V
C213	1-164-156-11	CERAMIC CHIP 0.1uF	25V
C214	1-164-156-11	CERAMIC CHIP 0.1uF	25V
C216	1-164-156-11	CERAMIC CHIP 0.1uF	25V
C217	1-164-156-11	CERAMIC CHIP 0.1uF	25V
C218	1-164-156-11	CERAMIC CHIP 0.1uF	25V
C219	1-164-156-11	CERAMIC CHIP 0.1uF	25V
C220	1-164-156-11	CERAMIC CHIP 0.1uF	25V
C221	1-164-156-11	CERAMIC CHIP 0.1uF	25V
C222	1-164-156-11	CERAMIC CHIP 0.1uF	25V
C223	1-164-677-11	CERAMIC CHIP 0.033uF	10.00% 16V
C224	1-107-826-11	CERAMIC CHIP 0.1uF	10.00% 16V
C225	1-107-826-11	CERAMIC CHIP 0.1uF	10.00% 16V
C226	1-107-826-11	CERAMIC CHIP 0.1uF	10.00% 16V
C227	1-162-914-11	CERAMIC CHIP 9PF	0.50PF 50V
C228	1-162-969-11	CERAMIC CHIP 0.0068uF	10% 25V
C230	1-162-914-11	CERAMIC CHIP 9PF	0.50PF 50V
C232	1-162-963-11	CERAMIC CHIP 680PF	10% 50V
C233	1-164-156-11	CERAMIC CHIP 0.1uF	25V
C234	1-165-908-11	CERAMIC CHIP 1uF	10% 10V
C235	1-125-891-11	CERAMIC CHIP 0.47	10.00% 10V
C236	1-164-156-11	CERAMIC CHIP 0.1uF	25V
C237	1-164-156-11	CERAMIC CHIP 0.1uF	25V
C238	1-164-156-11	CERAMIC CHIP 0.1uF	25V

Ref. No.	Part No.	Description	Remarks	Ref. No.	Part No.	Description	Remarks
C239	1-164-156-11	CERAMIC CHIP	0.1uF	25V		< DIODE >	
C240	1-164-156-11	CERAMIC CHIP	0.1uF	25V	D101	8-719-988-61	DIODE 1SS355TE-17
C241	1-164-156-11	CERAMIC CHIP	0.1uF	25V	D102	8-719-988-61	DIODE 1SS355TE-17
C242	1-164-156-11	CERAMIC CHIP	0.1uF	25V		< FERRITE BEAD >	
C244	1-126-390-11	ELECT CHIP	22uF	20.00% 6.3V			
C245	1-125-837-91	CERAMIC CHIP	1uF	10% 6.3V			
C246	1-107-826-11	CERAMIC CHIP	0.1uF	10.00% 16V	FB101	1-469-379-11	FERRITE 0uH
C247	1-107-826-11	CERAMIC CHIP	0.1uF	10.00% 16V	FB102	1-469-379-11	FERRITE 0uH
C248	1-164-156-11	CERAMIC CHIP	0.1uF	25V	FB103	1-469-379-11	FERRITE 0uH
C249	1-107-826-11	CERAMIC CHIP	0.1uF	10.00% 16V		< IC >	
C250	1-162-970-11	CERAMIC CHIP	0.01uF	10% 25V	IC101	6-701-749-01	IC AK8567
C251	1-162-970-11	CERAMIC CHIP	0.01uF	10% 25V	IC102	8-759-058-56	IC TC7S02FU(TE85R)
C254	1-164-156-11	CERAMIC CHIP	0.1uF	25V	IC103	8-759-337-41	IC NJM2902V-TE2
C257	1-164-156-11	CERAMIC CHIP	0.1uF	25V	IC104	8-759-096-87	IC TC7WU04FU(TE12R)
C258	1-164-156-11	CERAMIC CHIP	0.1uF	25V	IC110	8-759-594-95	IC L4931ABD33-TR
C259	1-162-964-11	CERAMIC CHIP	0.001uF	10% 50V	IC150	8-759-673-37	IC SN74HC00APWR
C260	1-162-964-11	CERAMIC CHIP	0.001uF	10% 50V	IC171	6-701-746-01	IC BA5937AFP-E2
C262	1-164-156-11	CERAMIC CHIP	0.1uF	25V	IC172	8-759-593-08	IC LB11698H-TE-L
C263	1-164-156-11	CERAMIC CHIP	0.1uF	25V	IC201	6-701-747-01	IC LC89587-UK1-E
C268	1-164-156-11	CERAMIC CHIP	0.1uF	25V	IC202	8-759-597-78	IC MSM54V16258BSL-40TSK
C269	1-126-392-11	ELECT CHIP	100uF	20.00% 6.3V	IC204	8-759-058-60	IC TC7SU04FU(TE85R)
C270	1-126-396-11	ELECT CHIP	47uF	20.00% 16V	IC301	8-759-549-25	IC SN74LVU04APWR
C271	1-126-392-11	ELECT CHIP	100uF	20.00% 6.3V	IC302	8-759-196-96	IC TC7SH08FU-TE85R
C272	1-164-156-11	CERAMIC CHIP	0.1uF	25V	IC501	6-803-240-01	IC HD6433064BA02FV
C273	1-126-391-11	ELECT CHIP	47uF	20.00% 6.3V	IC502	6-801-552-01	IC BR93LC46RF-WE2
C275	1-164-156-11	CERAMIC CHIP	0.1uF	25V	IC503	8-759-592-47	IC TC7SZ08FU(TE85R)
C289	1-164-156-11	CERAMIC CHIP	0.1uF	25V	IC504	8-759-485-79	IC TC7SET08FU(TE85R)
C301	1-164-156-11	CERAMIC CHIP	0.1uF	25V	IC505	8-759-592-47	IC TC7SZ08FU(TE85R)
C302	1-107-826-11	CERAMIC CHIP	0.1uF	10.00% 16V	IC506	8-759-485-79	IC TC7SET08FU(TE85R)
C303	1-164-156-11	CERAMIC CHIP	0.1uF	25V		< COIL >	
C304	1-107-826-11	CERAMIC CHIP	0.1uF	10.00% 16V	L101	1-414-398-11	INDUCTOR 10uH
C501	1-126-396-11	ELECT CHIP	47uF	20.00% 16V	L102	1-414-398-11	INDUCTOR 10uH
C502	1-162-964-11	CERAMIC CHIP	0.001uF	10% 50V	L103	1-414-392-41	INDUCTOR 1uH
C503	1-164-156-11	CERAMIC CHIP	0.1uF	25V	L202	1-414-392-41	INDUCTOR 1uH
C504	1-164-156-11	CERAMIC CHIP	0.1uF	25V	L203	1-414-392-41	INDUCTOR 1uH
C506	1-162-964-11	CERAMIC CHIP	0.001uF	10% 50V	L204	1-414-392-41	INDUCTOR 1uH
C508	1-164-156-11	CERAMIC CHIP	0.1uF	25V	L205	1-414-392-41	INDUCTOR 1uH
C509	1-162-964-11	CERAMIC CHIP	0.001uF	10% 50V	L207	1-414-392-41	INDUCTOR 1uH
C513	1-164-156-11	CERAMIC CHIP	0.1uF	25V	L208	1-414-392-41	INDUCTOR 1uH
C517	1-164-156-11	CERAMIC CHIP	0.1uF	25V	L301	1-414-392-41	INDUCTOR 1uH
C518	1-164-156-11	CERAMIC CHIP	0.1uF	25V	L303	1-414-392-41	INDUCTOR 1uH
C519	1-164-156-11	CERAMIC CHIP	0.1uF	25V	L501	1-414-392-41	INDUCTOR 1uH
C520	1-164-156-11	CERAMIC CHIP	0.1uF	25V	L503	1-414-392-41	INDUCTOR 1uH
C521	1-164-156-11	CERAMIC CHIP	0.1uF	25V		< RESISTOR >	
C526	1-164-156-11	CERAMIC CHIP	0.1uF	25V	R101	1-216-809-11	METAL CHIP 100 5% 1/10W
		< CONNECTOR >			R102	1-216-809-11	METAL CHIP 100 5% 1/10W
CN101	1-784-894-11	CONNECTOR, FFC/FPC 32P			R103	1-216-809-11	METAL CHIP 100 5% 1/10W
CN102	1-816-220-21	CONNECTOR, FFC/FPC 11P			R104	1-218-871-11	METAL CHIP 10K 0.5% 1/10W
CN103	1-816-220-21	CONNECTOR, FFC/FPC 11P			R106	1-216-829-11	METAL CHIP 4.7K 5% 1/10W
CN104	1-770-160-21	PIN, CONNECTOR (PC BOARD) 2P			R107	1-216-857-11	METAL CHIP 1M 5% 1/10W
CN110	1-784-370-21	CONNECTOR, FFC/FPC 11P			R108	1-216-809-11	METAL CHIP 100 5% 1/10W
* CN111	1-764-250-11	PIN, CONNECTOR (PC BOARD) 4P			R109	1-216-809-11	METAL CHIP 100 5% 1/10W
CN112	1-784-365-21	CONNECTOR, FFC/FPC 5P			R110	1-216-809-11	METAL CHIP 100 5% 1/10W
CN115	1-770-160-21	PIN, CONNECTOR (PC BOARD) 2P			R111	1-218-883-11	METAL CHIP 33K 0.5% 1/10W
CN121	1-774-731-21	PIN, CONNECTOR (PC BOARD) 5P			R112	1-218-879-11	METAL CHIP 22K 0.5% 1/10W

RCD-W500C

CDR

Ref. No.	Part No.	Description	Quantity	Percentage	Remarks	Ref. No.	Part No.	Description	Quantity	Percentage	Remarks
R113	1-218-855-11	METAL CHIP	2.2K	0.5%	1/10W	R217	1-216-864-11	METAL CHIP	0	5%	1/10W
R114	1-218-847-11	METAL CHIP	1K	0.5%	1/10W	R218	1-216-801-11	METAL CHIP	22	5%	1/10W
R116	1-218-847-11	METAL CHIP	1K	0.5%	1/10W	R219	1-216-801-11	METAL CHIP	22	5%	1/10W
R120	1-216-809-11	METAL CHIP	100	5%	1/10W	R220	1-216-801-11	METAL CHIP	22	5%	1/10W
R121	1-216-809-11	METAL CHIP	100	5%	1/10W	R221	1-216-801-11	METAL CHIP	22	5%	1/10W
R122	1-216-857-11	METAL CHIP	1M	5%	1/10W	R222	1-216-801-11	METAL CHIP	22	5%	1/10W
R123	1-216-864-11	METAL CHIP	0	5%	1/10W	R223	1-216-801-11	METAL CHIP	22	5%	1/10W
R124	1-216-825-11	METAL CHIP	2.2K	5%	1/10W	R224	1-216-801-11	METAL CHIP	22	5%	1/10W
R125	1-216-797-11	METAL CHIP	10	5%	1/10W	R225	1-216-833-11	METAL CHIP	10K	5%	1/10W
R126	1-216-864-11	METAL CHIP	0	5%	1/10W	R226	1-216-864-11	METAL CHIP	0	5%	1/10W
R127	1-218-883-11	METAL CHIP	33K	0.5%	1/10W	R228	1-216-833-11	METAL CHIP	10K	5%	1/10W
R128	1-218-879-11	METAL CHIP	22K	0.5%	1/10W	R229	1-216-864-11	METAL CHIP	0	5%	1/10W
R133	1-216-864-11	METAL CHIP	0	5%	1/10W	R230	1-216-817-11	METAL CHIP	470	5%	1/10W
R134	1-218-871-11	METAL CHIP	10K	0.5%	1/10W	R231	1-216-809-11	METAL CHIP	100	5%	1/10W
R135	1-218-863-11	METAL CHIP	4.7K	0.5%	1/10W	R232	1-216-864-11	METAL CHIP	0	5%	1/10W
R136	1-218-871-11	METAL CHIP	10K	0.5%	1/10W	R241	1-216-809-11	METAL CHIP	100	5%	1/10W
R137	1-218-867-11	METAL CHIP	6.8K	0.5%	1/10W	R242	1-218-867-11	METAL CHIP	6.8K	0.5%	1/10W
R139	1-216-833-11	METAL CHIP	10K	5%	1/10W	R243	1-218-867-11	METAL CHIP	6.8K	0.5%	1/10W
R140	1-216-833-11	METAL CHIP	10K	5%	1/10W	R244	1-216-864-11	METAL CHIP	0	5%	1/10W
R141	1-216-833-11	METAL CHIP	10K	5%	1/10W	R245	1-216-829-11	METAL CHIP	4.7K	5%	1/10W
R142	1-216-833-11	METAL CHIP	10K	5%	1/10W	R246	1-216-833-11	METAL CHIP	10K	5%	1/10W
R153	1-216-809-11	METAL CHIP	100	5%	1/10W	R248	1-218-831-11	METAL CHIP	220	0.5%	1/10W
R154	1-216-809-11	METAL CHIP	100	5%	1/10W	R250	1-218-871-11	METAL CHIP	10K	0.5%	1/10W
R155	1-216-809-11	METAL CHIP	100	5%	1/10W	R251	1-218-879-11	METAL CHIP	22K	0.5%	1/10W
R156	1-216-809-11	METAL CHIP	100	5%	1/10W	R253	1-216-864-11	METAL CHIP	0	5%	1/10W
R157	1-216-797-11	METAL CHIP	10	5%	1/10W	R254	1-216-857-11	METAL CHIP	1M	5%	1/10W
R158	1-216-845-11	METAL CHIP	100K	5%	1/10W	R258	1-216-833-11	METAL CHIP	10K	5%	1/10W
R159	1-216-821-11	METAL CHIP	1K	5%	1/10W	R260	1-216-833-11	METAL CHIP	10K	5%	1/10W
R160	1-216-837-11	METAL CHIP	22K	5%	1/10W	R262	1-218-871-11	METAL CHIP	10K	0.5%	1/10W
R170	1-216-797-11	METAL CHIP	10	5%	1/10W	R263	1-218-871-11	METAL CHIP	10K	0.5%	1/10W
R171	1-216-797-11	METAL CHIP	10	5%	1/10W	R264	1-216-797-11	METAL CHIP	10	5%	1/10W
R172	1-216-797-11	METAL CHIP	10	5%	1/10W	R265	1-218-833-11	METAL CHIP	270	0.5%	1/10W
R173	1-218-831-11	METAL CHIP	220	0.5%	1/10W	R267	1-218-883-11	METAL CHIP	33K	0.5%	1/10W
R186	1-216-845-11	METAL CHIP	100K	5%	1/10W	R268	1-218-864-11	METAL CHIP	5.1K	0.5%	1/10W
R187	1-216-833-11	METAL CHIP	10K	5%	1/10W	R269	1-216-817-11	METAL CHIP	470	5%	1/10W
R188	1-216-864-11	METAL CHIP	0	5%	1/10W	R270	1-218-847-11	METAL CHIP	1K	0.5%	1/10W
R189	1-216-829-11	METAL CHIP	4.7K	5%	1/10W	R271	1-218-865-11	METAL CHIP	5.6K	0.5%	1/10W
R190	1-216-829-11	METAL CHIP	4.7K	5%	1/10W	R274	1-216-833-11	METAL CHIP	10K	5%	1/10W
R192	1-216-864-11	METAL CHIP	0	5%	1/10W	R276	1-218-843-11	METAL CHIP	680	0.5%	1/10W
R193	1-220-810-11	RES-CHIP	0.39	1%	1/2W	R277	1-218-865-11	METAL CHIP	5.6K	0.5%	1/10W
R194	1-216-864-11	METAL CHIP	0	5%	1/10W	R278	1-218-285-11	METAL CHIP	75	5%	1/10W
R196	1-216-864-11	METAL CHIP	0	5%	1/10W	R281	1-218-847-11	METAL CHIP	1K	0.5%	1/10W
R198	1-216-864-11	METAL CHIP	0	5%	1/10W	R283	1-216-809-11	METAL CHIP	100	5%	1/10W
R200	1-216-829-11	METAL CHIP	4.7K	5%	1/10W	R290	1-216-833-11	METAL CHIP	10K	5%	1/10W
R201	1-216-801-11	METAL CHIP	22	5%	1/10W	R291	1-216-811-11	METAL CHIP	150	5%	1/10W
R202	1-216-817-11	METAL CHIP	470	5%	1/10W	R300	1-216-833-11	METAL CHIP	10K	5%	1/10W
R203	1-216-801-11	METAL CHIP	22	5%	1/10W	R301	1-216-845-11	METAL CHIP	100K	5%	1/10W
R204	1-216-801-11	METAL CHIP	22	5%	1/10W	R302	1-216-845-11	METAL CHIP	100K	5%	1/10W
R205	1-216-801-11	METAL CHIP	22	5%	1/10W	R303	1-216-833-11	METAL CHIP	10K	5%	1/10W
R206	1-216-864-11	METAL CHIP	0	5%	1/10W	R304	1-216-833-11	METAL CHIP	10K	5%	1/10W
R207	1-216-813-11	METAL CHIP	220	5%	1/10W	R305	1-216-864-11	METAL CHIP	0	5%	1/10W
R208	1-216-864-11	METAL CHIP	0	5%	1/10W	R307	1-216-864-11	METAL CHIP	0	5%	1/10W
R209	1-216-801-11	METAL CHIP	22	5%	1/10W	R320	1-216-864-11	METAL CHIP	0	5%	1/10W
R210	1-216-864-11	METAL CHIP	0	5%	1/10W	R321	1-216-864-11	METAL CHIP	0	5%	1/10W
R211	1-216-801-11	METAL CHIP	22	5%	1/10W	R322	1-216-864-11	METAL CHIP	0	5%	1/10W
R213	1-216-817-11	METAL CHIP	470	5%	1/10W	R323	1-216-864-11	METAL CHIP	0	5%	1/10W
R215	1-216-864-11	METAL CHIP	0	5%	1/10W	R324	1-216-864-11	METAL CHIP	0	5%	1/10W
R216	1-218-875-11	METAL CHIP	15K	0.5%	1/10W						

CDR

CLAMP MOTOR

CONNECTOR

Ref. No.	Part No.	Description	Quantity	Percentage	Remarks	Ref. No.	Part No.	Description	Quantity	Percentage	Remarks
R325	1-216-864-11	METAL CHIP	0	5%	1/10W	RB511	1-233-810-21	RES, NETWORK 100K (3216)			
R350	1-216-821-11	METAL CHIP	1K	5%	1/10W	RB512	1-233-810-21	RES, NETWORK 100K (3216)			
R351	1-216-821-11	METAL CHIP	1K	5%	1/10W	RB514	1-233-810-21	RES, NETWORK 100K (3216)			
R353	1-216-833-11	METAL CHIP	10K	5%	1/10W						
R354	1-216-833-11	METAL CHIP	10K	5%	1/10W	RB515	1-233-810-21	RES, NETWORK 100K (3216)			
R356	1-216-789-11	METAL CHIP	2.2	5%	1/10W	RB516	1-233-810-21	RES, NETWORK 100K (3216)			
R369	1-216-789-11	METAL CHIP	2.2	5%	1/10W	RB517	1-233-810-21	RES, NETWORK 100K (3216)			
R370	1-216-789-11	METAL CHIP	2.2	5%	1/10W	RB518	1-233-810-21	RES, NETWORK 100K (3216)			
R502	1-216-809-11	METAL CHIP	100	5%	1/10W	RB519	1-233-810-21	RES, NETWORK 100K (3216)			
R503	1-216-809-11	METAL CHIP	100	5%	1/10W						
R504	1-216-864-11	METAL CHIP	0	5%	1/10W	RB520	1-233-810-21	RES, NETWORK 100K (3216)			
R505	1-216-841-11	METAL CHIP	47K	5%	1/10W	RB521	1-233-810-21	RES, NETWORK 100K (3216)			
R506	1-216-864-11	METAL CHIP	0	5%	1/10W	RB522	1-233-810-21	RES, NETWORK 100K (3216)			
R507	1-216-864-11	METAL CHIP	0	5%	1/10W			< SWITCH >			
R508	1-216-864-11	METAL CHIP	0	5%	1/10W	S170	1-786-288-11	SWITCH, DETECTION (LOAD IN)			
R509	1-216-833-11	METAL CHIP	10K	5%	1/10W	S171	1-786-288-11	SWITCH, DETECTION (LOAD OUT)			
R511	1-216-864-11	METAL CHIP	0	5%	1/10W			< VIBRATOR >			
R513	1-216-864-11	METAL CHIP	0	5%	1/10W						
R515	1-216-864-11	METAL CHIP	0	5%	1/10W	X201	1-795-519-11	VIBRATOR, CRYSTAL (33.8688MHz)			
R519	1-216-864-11	METAL CHIP	0	5%	1/10W	X501	1-795-622-21	VIBRATOR, CERAMIC (20MHz)			
R522	1-216-845-11	METAL CHIP	100K	5%	1/10W	*****					
R523	1-216-845-11	METAL CHIP	100K	5%	1/10W		1-675-729-11	CLAMP MOTOR BOARD			
R524	1-216-845-11	METAL CHIP	100K	5%	1/10W			*****			
R525	1-216-845-11	METAL CHIP	100K	5%	1/10W			< CAPACITOR >			
R526	1-216-864-11	METAL CHIP	0	5%	1/10W						
R527	1-216-864-11	METAL CHIP	0	5%	1/10W	C701	1-162-306-11	CERAMIC	0.01uF	30.00%	16V
R528	1-216-864-11	METAL CHIP	0	5%	1/10W	C702	1-126-964-11	ELECT	10uF	20.00%	50V
R529	1-216-825-11	METAL CHIP	2.2K	5%	1/10W	C706	1-162-306-11	CERAMIC	0.01uF	30.00%	16V
R530	1-216-864-11	METAL CHIP	0	5%	1/10W	C711	1-162-306-11	CERAMIC	0.01uF	30.00%	16V
R532	1-216-864-11	METAL CHIP	0	5%	1/10W			< CONNECTOR >			
R533	1-216-864-11	METAL CHIP	0	5%	1/10W						
R534	1-216-829-11	METAL CHIP	4.7K	5%	1/10W	* CN712	1-568-954-11	PIN, CONNECTOR 5P			
R535	1-216-864-11	METAL CHIP	0	5%	1/10W			< DIODE >			
R536	1-216-864-11	METAL CHIP	0	5%	1/10W						
R537	1-216-864-11	METAL CHIP	0	5%	1/10W	D701	8-719-983-66	DIODE MTZJ-T-72-3.6B			
R538	1-216-864-11	METAL CHIP	0	5%	1/10W			< IC >			
R539	1-216-864-11	METAL CHIP	0	5%	1/10W						
R540	1-216-833-11	METAL CHIP	10K	5%	1/10W	IC701	8-759-633-65	IC M54641L			
R542	1-216-833-11	METAL CHIP	10K	5%	1/10W			< RESISTOR >			
R543	1-216-833-11	METAL CHIP	10K	5%	1/10W						
R544	1-216-813-11	METAL CHIP	220	5%	1/10W	R701	1-249-411-11	CARBON	330	5%	1/4W
R545	1-216-801-11	METAL CHIP	22	5%	1/10W	R702	1-249-401-11	CARBON	47	5%	1/4W F
R546	1-216-864-11	METAL CHIP	0	5%	1/10W	*****					
R547	1-216-864-11	METAL CHIP	0	5%	1/10W		1-675-722-11	CONNECTOR BOARD			
R548	1-216-813-11	METAL CHIP	220	5%	1/10W			*****			
R549	1-216-864-11	METAL CHIP	0	5%	1/10W			< CONNECTOR >			
R550	1-216-864-11	METAL CHIP	0	5%	1/10W						
R555	1-216-845-11	METAL CHIP	100K	5%	1/10W	CN701	1-770-169-11	CONNECTOR, FFC/FPC 17P			
R556	1-216-845-11	METAL CHIP	100K	5%	1/10W			< TRANSISTOR >			
< COMPOSITION CIRCUIT BLOCK >											
RB201	1-233-810-21	RES, NETWORK 100K (3216)									
RB504	1-233-810-21	RES, NETWORK 100K (3216)									
RB505	1-233-810-21	RES, NETWORK 100K (3216)				Q701	8-729-029-66	TRANSISTOR			RT1N141S-TP
RB506	1-233-810-21	RES, NETWORK 100K (3216)						< RESISTOR >			
RB508	1-233-810-21	RES, NETWORK 100K (3216)									
RB509	1-233-810-21	RES, NETWORK 100K (3216)				R707	1-249-424-11	CARBON	3.9K	5%	1/4W F
RB510	1-233-810-21	RES, NETWORK 100K (3216)				R708	1-249-417-11	CARBON	1K	5%	1/4W F
						R709	1-249-429-11	CARBON	10K	5%	1/4W

RCD-W500C

DISP **HP**

Ref. No.	Part No.	Description	Remarks
	A-4732-814-A	DISP BOARD, COMPLETE *****	
	4-949-935-41	CUSHION (FL)	
*	4-996-686-03	HOLDER (FL)	
< CAPACITOR >			
C742	1-124-584-00	ELECT	100uF 20% 10V
C743	1-164-159-11	CERAMIC	0.1uF 50V
C751	1-124-261-00	ELECT	10uF 20% 50V
C753	1-124-261-00	ELECT	10uF 20% 50V
C760	1-124-261-00	ELECT	10uF 20% 50V
C761	1-162-294-31	CERAMIC	0.001uF 10% 50V
C762	1-162-294-31	CERAMIC	0.001uF 10% 50V
C763	1-164-159-11	CERAMIC	0.1uF 50V
C764	1-124-261-00	ELECT	10uF 20% 50V
C765	1-164-159-11	CERAMIC	0.1uF 50V
C766	1-162-213-31	CERAMIC	39PF 5% 50V
C767	1-164-159-11	CERAMIC	0.1uF 50V
C768	1-162-294-31	CERAMIC	0.001uF 10% 50V
C769	1-162-294-31	CERAMIC	0.001uF 10% 50V
C770	1-162-294-31	CERAMIC	0.001uF 10% 50V
< CONNECTOR >			
CN700	1-779-558-21	CONNECTOR,FFC (LIF (NON-ZIF)) 21P	
* CN710	1-695-823-11	CONNECTOR, BOARD TO BOARD 8P	
< DIODE >			
D775	8-719-046-39	DIODE SEL5821A-TP15 (SBM)	
< FILTER >			
FL750	1-518-898-11	INDICATOR TUBE, FLUORESCENT	
< IC >			
IC760	8-759-680-17	IC MSM9201-04GS-K	
IC781	8-759-826-33	IC NJL73H400A (B)	
< TRANSISTOR >			
Q761	8-729-620-05	TRANSISTOR	2SC2603TP-EF
Q762	8-729-620-05	TRANSISTOR	2SC2603TP-EF
Q775	8-729-900-80	TRANSISTOR	UN4211-TA
< RESISTOR >			
R700	1-249-409-11	CARBON	220 5% 1/4W F
R701	1-249-411-11	CARBON	330 5% 1/4W
R702	1-249-413-11	CARBON	470 5% 1/4W F
R703	1-249-415-11	CARBON	680 5% 1/4W F
R704	1-249-417-11	CARBON	1K 5% 1/4W F
R711	1-249-409-11	CARBON	220 5% 1/4W F
R712	1-249-411-11	CARBON	330 5% 1/4W
R713	1-249-413-11	CARBON	470 5% 1/4W F
R714	1-249-415-11	CARBON	680 5% 1/4W F
R715	1-249-417-11	CARBON	1K 5% 1/4W F
R716	1-249-419-11	CARBON	1.5K 5% 1/4W F
R717	1-249-421-11	CARBON	2.2K 5% 1/4W F
R718	1-249-425-11	CARBON	4.7K 5% 1/4W F
R719	1-249-429-11	CARBON	10K 5% 1/4W
R721	1-249-409-11	CARBON	220 5% 1/4W F

Ref. No.	Part No.	Description	Remarks
R722	1-249-411-11	CARBON	330 5% 1/4W
R723	1-249-413-11	CARBON	470 5% 1/4W F
R724	1-249-415-11	CARBON	680 5% 1/4W F
R741	1-247-807-31	CARBON	100 5% 1/4W
R742	1-249-401-11	CARBON	47 5% 1/4W F
R761	1-247-807-31	CARBON	100 5% 1/4W
R762	1-247-807-31	CARBON	100 5% 1/4W
R763	1-249-441-11	CARBON	100K 5% 1/4W
R764	1-249-441-11	CARBON	100K 5% 1/4W
R766	1-247-843-11	CARBON	3.3K 5% 1/4W
R767	1-247-807-31	CARBON	100 5% 1/4W
R768	1-247-807-31	CARBON	100 5% 1/4W
R769	1-247-807-31	CARBON	100 5% 1/4W
R770	1-247-807-31	CARBON	100 5% 1/4W
R775	1-247-807-31	CARBON	100 5% 1/4W
< VARIABLE RESISTOR >			
RV780	1-223-673-11	RES, VAR, CARBON 10K (REC LEVEL)	
< SWITCH >			
S700	1-762-875-21	SWITCH, KEYBOARD (ERASE)	
S701	1-762-875-21	SWITCH, KEYBOARD (FINALIZE)	
S702	1-762-875-21	SWITCH, KEYBOARD (INPUT)	
S703	1-762-875-21	SWITCH, KEYBOARD (SBM)	
S704	1-762-875-21	SWITCH, KEYBOARD (REC)	
S710	1-762-875-21	SWITCH, KEYBOARD (▷) (RCD))	
S711	1-762-875-21	SWITCH, KEYBOARD (■) (RCD))	
S712	1-762-875-21	SWITCH, KEYBOARD (■) (RCD))	
S713	1-762-875-21	SWITCH, KEYBOARD (PLAY MODE (RCD))	
S714	1-762-875-21	SWITCH, KEYBOARD (TIME (RCD))	
S715	1-762-875-21	SWITCH, KEYBOARD (DISPLAY)	
S716	1-762-875-21	SWITCH, KEYBOARD (YES)	
S717	1-477-995-11	ENCODER, ROTARY (AMS (RCD))	
S718	1-762-875-21	SWITCH, KEYBOARD (MENU/NO)	
S719	1-762-875-21	SWITCH, KEYBOARD (CLEAR)	
S720	1-762-875-21	SWITCH, KEYBOARD (OPEN/CLOSE(RCD))	
S721	1-762-875-21	SWITCH, KEYBOARD (NORMAL)	
S722	1-762-875-21	SWITCH, KEYBOARD (HIGHT)	
S723	1-477-995-11	ENCODER, ROTARY (AMS (CD))	
S724	1-762-875-21	SWITCH, KEYBOARD (ALBUM)	

	1-683-868-21	HP BOARD *****	
< CAPACITOR >			
C791	1-162-290-31	CERAMIC	470PF 10% 50V
C796	1-162-290-31	CERAMIC	470PF 10% 50V
< JACK >			
J790	1-770-306-11	JACK (LARGE TYPE)(PHONES)	
< CAPACITOR >			
L790	1-164-159-11	CERAMIC	0.1uF 50V

HP	INIT/COUNT SW	IN SW	LED	LOAD MOTOR	MAIN
-----------	----------------------	--------------	------------	-------------------	-------------

Ref. No.	Part No.	Description	Remarks	Ref. No.	Part No.	Description	Remarks
		< RESISTOR >		R706	1-216-823-11	METAL CHIP 1.5K 5%	1/10W
R791	1-249-393-11	CARBON 10 5%	1/4W F	R707	1-216-825-11	METAL CHIP 2.2K 5%	1/10W
R796	1-249-393-11	CARBON 10 5%	1/4W F	R708	1-216-829-11	METAL CHIP 4.7K 5%	1/10W
		< VARIABLE RESISTOR >		R709	1-216-833-11	METAL CHIP 10K 5%	1/10W
RV790	1-225-741-11	RES, VAR, CARBON 20K/20K (PHONE LEVEL)		R760	1-216-801-11	METAL CHIP 22 5%	1/10W
		*****		R761	1-216-801-11	METAL CHIP 22 5%	1/10W
	1-675-724-11	INIT/COUNT SW BOARD		R780	1-216-833-11	METAL CHIP 10K 5%	1/10W
		*****				< COMPOSITION CIRCUIT BLOCK >	
		< SWITCH >		RB753	1-233-576-11	RES, CHIP NETWORK 100	
S705	1-771-264-11	SWITCH, PUSH (DETECTION) (1 KEY) (INIT)		RB756	1-233-575-11	RES, CHIP NETWORK 22	
S706	1-771-264-11	SWITCH, PUSH (DETECTION) (1 KEY) (COUNT)		RB762	1-233-575-11	RES, CHIP NETWORK 22	
		*****				< SWITCH >	
	1-675-723-11	IN SW BOARD		S700	1-762-875-21	SWITCH, KEYBOARD (DISC 1)	
		*****		S701	1-762-875-21	SWITCH, KEYBOARD (≡)	
		< CONNECTOR >		S702	1-762-875-21	SWITCH, KEYBOARD (DISC 2)	
* CN710	1-568-941-11	PIN, CONNECTOR 3P		S703	1-762-875-21	SWITCH, KEYBOARD (≡)	
		< SWITCH >		S704	1-762-875-21	SWITCH, KEYBOARD (DISC 3)	
S703	1-771-218-11	SWITCH, MICRO (MID IN)		S705	1-762-875-21	SWITCH, KEYBOARD (≡)	
S704	1-771-218-11	SWITCH, MICRO (IN)		S706	1-762-875-21	SWITCH, KEYBOARD (DISC 4)	
		*****		S707	1-762-875-21	SWITCH, KEYBOARD (≡)	
	A-4732-812-A	LED BOARD, COMPLETE		S708	1-762-875-21	SWITCH, KEYBOARD (DISC 5)	
		*****		S709	1-762-875-21	SWITCH, KEYBOARD (≡)	
		< CAPACITOR >				*****	
C750	1-164-156-11	CERAMIC CHIP 0.1uF	25V	1-675-728-11	LOAD MOTOR BOARD		
C751	1-124-225-91	ELECT 1uF 20%	50V		*****		
C755	1-162-962-11	CERAMIC CHIP 470PF 10%	50V		< CAPACITOR >		
		< CONNECTOR >		C703	1-162-306-11	CERAMIC 0.01uF 30.00%	16V
* CN780	1-695-822-11	CONNECTOR,BOARD TO BOARD 8P		C704	1-126-964-11	ELECT 10uF 20.00%	50V
		< DIODE >		C705	1-162-306-11	CERAMIC 0.01uF 30.00%	16V
D751	8-719-079-89	DIODE SML-020MDT-T86 (DISC 1)		C712	1-162-306-11	CERAMIC 0.01uF 30.00%	16V
D752	8-719-079-89	DIODE SML-020MDT-T86 (DISC 2)				< CONNECTOR >	
D753	8-719-079-89	DIODE SML-020MDT-T86 (DISC 3)		* CN713	1-568-954-11	PIN, CONNECTOR 5P	
D754	8-719-079-89	DIODE SML-020MDT-T86 (DISC 4)				< DIODE >	
D755	8-719-079-89	DIODE SML-020MDT-T86 (DISC 5)		D702	8-719-109-85	DIODE MTZJ-T-72-5.1B	
		< IC >				< IC >	
IC750	6-704-046-01	IC BU2099FV		IC702	8-759-633-65	IC M54641L	
		< TRANSISTOR >				< RESISTOR >	
Q780	8-729-015-76	TRANSISTOR UN5211-TX		R703	1-249-411-11	CARBON 330 5%	1/4W
		< RESISTOR >		R704	1-249-401-11	CARBON 47 5%	1/4W F
R701	1-216-813-11	METAL CHIP 220 5%	1/10W			*****	
R702	1-216-815-11	METAL CHIP 330 5%	1/10W	A-4732-811-A	MAIN BOARD, COMPLETE		
R703	1-216-817-11	METAL CHIP 470 5%	1/10W		*****		
R704	1-216-819-11	METAL CHIP 680 5%	1/10W	* 3-923-762-11	HOLDER (TR)		
R705	1-216-821-11	METAL CHIP 1K 5%	1/10W	7-685-646-79	SCREW +BVTP 3X8 TYPE2 IT-3		
		< CAPACITOR >				< CAPACITOR >	
				C12	1-164-156-11	CERAMIC CHIP 0.1uF	25V
				C16	1-164-156-11	CERAMIC CHIP 0.1uF	25V
				C62	1-164-156-11	CERAMIC CHIP 0.1uF	25V

MAIN

Ref. No.	Part No.	Description	Remarks	Ref. No.	Part No.	Description	Remarks
C79	1-162-971-11	CERAMIC CHIP	0.001uF 10.00% 50V	C465	1-126-967-11	ELECT	47uF 20.00% 50V
C91	1-164-156-11	CERAMIC CHIP	0.1uF 25V	C471	1-126-964-11	ELECT	10uF 20.00% 50V
C98	1-164-156-11	CERAMIC CHIP	0.1uF 25V	C472	1-126-967-11	ELECT	47uF 20.00% 50V
C99	1-104-665-11	ELECT	100uF 20.00% 10V	C476	1-164-156-11	CERAMIC CHIP	0.1uF 25V
C100	1-164-156-11	CERAMIC CHIP	0.1uF 25V	C480	1-164-156-11	CERAMIC CHIP	0.1uF 25V
C111	1-136-356-11	MYLAR	470PF 5.00% 50V	C481	1-162-974-11	CERAMIC CHIP	0.01uF 50V
C112	1-128-551-11	ELECT	22uF 20.00% 25V	C500	1-164-156-11	CERAMIC CHIP	0.1uF 25V
C113	1-128-551-11	ELECT	22uF 20.00% 25V	C503	1-164-156-11	CERAMIC CHIP	0.1uF 25V
C118	1-128-551-11	ELECT	22uF 20.00% 25V	C504	1-164-156-11	CERAMIC CHIP	0.1uF 25V
C170	1-128-551-11	ELECT	22uF 20.00% 25V	C505	1-164-156-11	CERAMIC CHIP	0.1uF 25V
C173	1-128-551-11	ELECT	22uF 20.00% 25V	C517	1-104-665-11	ELECT	100uF 20.00% 10V
C174	1-136-356-11	MYLAR	470PF 5.00% 50V	C518	1-164-156-11	CERAMIC CHIP	0.1uF 25V
C211	1-136-356-11	MYLAR	470PF 5.00% 50V	C519	1-104-665-11	ELECT	100uF 20.00% 10V
C212	1-128-551-11	ELECT	22uF 20.00% 25V	C520	1-164-156-11	CERAMIC CHIP	0.1uF 25V
C213	1-128-551-11	ELECT	22uF 20.00% 25V	C530	1-104-665-11	ELECT	100uF 20.00% 10V
C218	1-128-551-11	ELECT	22uF 20.00% 25V	C531	1-164-156-11	CERAMIC CHIP	0.1uF 25V
C270	1-128-551-11	ELECT	22uF 20.00% 25V	C534	1-164-156-11	CERAMIC CHIP	0.1uF 25V
C273	1-128-551-11	ELECT	22uF 20.00% 25V	C535	1-104-665-11	ELECT	100uF 20.00% 10V
C274	1-136-356-11	MYLAR	470PF 5.00% 50V	C536	1-164-156-11	CERAMIC CHIP	0.1uF 25V
C310	1-164-156-11	CERAMIC CHIP	0.1uF 25V	C539	1-104-665-11	ELECT	100uF 20.00% 10V
C311	1-126-933-11	ELECT	100uF 20.00% 16V	C541	1-164-156-11	CERAMIC CHIP	0.1uF 25V
C312	1-164-156-11	CERAMIC CHIP	0.1uF 25V	C550	1-164-156-11	CERAMIC CHIP	0.1uF 25V
C316	1-126-933-11	ELECT	100uF 20.00% 16V	C555	1-164-156-11	CERAMIC CHIP	0.1uF 25V
C317	1-164-156-11	CERAMIC CHIP	0.1uF 25V	C600	1-126-963-11	ELECT	4.7uF 20.00% 50V
C361	1-126-933-11	ELECT	100uF 20.00% 16V	C611	1-164-156-11	CERAMIC CHIP	0.1uF 25V
C362	1-164-156-11	CERAMIC CHIP	0.1uF 25V	C613	1-216-864-11	METAL CHIP	0 5% 1/10W
C366	1-126-933-11	ELECT	100uF 20.00% 16V	C621	1-164-156-11	CERAMIC CHIP	0.1uF 25V
C367	1-164-156-11	CERAMIC CHIP	0.1uF 25V	C630	1-216-864-11	METAL CHIP	0 5% 1/10W
C391	1-164-156-11	CERAMIC CHIP	0.1uF 25V	C631	1-164-156-11	CERAMIC CHIP	0.1uF 25V
C396	1-164-156-11	CERAMIC CHIP	0.1uF 25V	C650	1-104-665-11	ELECT	100uF 20.00% 10V
C401	1-126-767-11	ELECT	1000uF 20.00% 16V	C651	1-164-156-11	CERAMIC CHIP	0.1uF 25V
C403	1-126-767-11	ELECT	1000uF 20.00% 16V	C661	1-164-156-11	CERAMIC CHIP	0.1uF 25V
C406	1-126-935-11	ELECT	470uF 20.00% 16V	C664	1-164-156-11	CERAMIC CHIP	0.1uF 25V
C411	1-126-939-11	ELECT	10000uF 20.00% 16V	△C900	1-113-920-11	CERAMIC	0.0022uF 20.00% 250V
C412	1-164-156-11	CERAMIC CHIP	0.1uF 25V	△C901	1-113-920-11	CERAMIC	0.0022uF 20.00% 250V
C413	1-164-156-11	CERAMIC CHIP	0.1uF 25V	< CONNECTOR >			
C414	1-126-926-11	ELECT	1000uF 20.00% 10V	CN1	1-784-367-11	CONNECTOR, FFC/FPC 8P	
C421	1-126-939-11	ELECT	10000uF 20.00% 16V	CN630	1-784-370-21	CONNECTOR, FFC/FPC 11P	
C422	1-164-156-11	CERAMIC CHIP	0.1uF 25V	CN640	1-784-376-11	CONNECTOR, FFC/FPC 17P	
C423	1-164-156-11	CERAMIC CHIP	0.1uF 25V	* CN641	1-568-954-11	PIN, CONNECTOR 5P	
C424	1-126-926-11	ELECT	1000uF 20.00% 10V	CN660	1-784-382-21	CONNECTOR, FFC/FPC 25P	
C426	1-164-156-11	CERAMIC CHIP	0.1uF 25V	CN661	1-784-368-11	CONNECTOR, FFC/FPC 9P	
C427	1-164-156-11	CERAMIC CHIP	0.1uF 25V	CN671	1-778-692-11	CONNECTOR, FFC/FPC 21P	
C428	1-126-935-11	ELECT	470uF 20.00% 6.3V	CN690	1-506-468-11	PIN, CONNECTOR 3P	
C431	1-128-548-11	ELECT	4700uF 20.00% 25V	CN900	1-564-321-00	PIN, CONNECTOR 2P	
C432	1-164-156-11	CERAMIC CHIP	0.1uF 25V	< DIODE >			
C433	1-164-156-11	CERAMIC CHIP	0.1uF 25V	D181	8-719-820-05	DIODE 1SS181-TE85L	
C434	1-126-926-11	ELECT	1000uF 20.00% 10V	D310	8-719-988-61	DIODE 1SS355TE-17	
C442	1-164-156-11	CERAMIC CHIP	0.1uF 25V	D311	8-719-801-78	DIODE 1SS184-TE85L	
C443	1-164-156-11	CERAMIC CHIP	0.1uF 25V	D316	8-719-820-05	DIODE 1SS181-TE85L	
C444	1-126-926-11	ELECT	1000uF 20.00% 10V	D400	8-719-421-18	DIODE MA8033-L-TX	
C451	1-128-548-11	ELECT	4700uF 20.00% 25V	D401	6-500-522-21	DIODE 10EDB40-TB3	
C452	1-164-156-11	CERAMIC CHIP	0.1uF 25V	D402	6-500-522-21	DIODE 10EDB40-TB3	
C453	1-164-156-11	CERAMIC CHIP	0.1uF 25V	<div style="display: flex; justify-content: space-between;"> <div style="width: 45%;"> <p>The components identified by mark △ or dotted line with mark △ are critical for safety. Replace only with part number specified.</p> </div> <div style="width: 45%;"> <p>Les composants identifiés par une marque △ sont critiques pour la sécurité. Ne les remplacer que par une pièce portant le numéro spécifié.</p> </div> </div>			
C454	1-126-926-11	ELECT	1000uF 20.00% 10V				
C460	1-128-576-11	ELECT	100uF 20.00% 63V				
C463	1-165-319-11	CERAMIC CHIP	0.1uF 50V				

Ref. No.	Part No.	Description	Remarks	Ref. No.	Part No.	Description	Remarks
D403	6-500-522-21	DIODE 10EDB40-TB3		L659	1-414-760-21	FERRITE 0uH	
D404	6-500-522-21	DIODE 10EDB40-TB3		L661	1-216-864-11	METAL CHIP 0 5% 1/10W	
D406	6-500-522-21	DIODE 10EDB40-TB3		L662	1-216-295-91	SHORT CHIP 0	
D407	6-500-522-21	DIODE 10EDB40-TB3		L665	1-216-295-91	SHORT CHIP 0	
D411	6-500-522-21	DIODE 10EDB40-TB3				< LINE FILTER >	
D412	6-500-522-21	DIODE 10EDB40-TB3		△ LF900	1-419-625-11	COIL, LINE FILTER	
D421	6-500-522-21	DIODE 10EDB40-TB3				< TRANSISTOR >	
D422	6-500-522-21	DIODE 10EDB40-TB3		Q181	8-729-046-97	TRANSISTOR 2SD1938 (F) -T (TX). SO	
D431	6-500-522-21	DIODE 10EDB40-TB3		Q191	8-729-424-67	TRANSISTOR UN2216-TX	
D432	6-500-522-21	DIODE 10EDB40-TB3		Q281	8-729-046-97	TRANSISTOR 2SD1938 (F) -T (TX). SO	
D433	6-500-522-21	DIODE 10EDB40-TB3		Q291	8-729-424-67	TRANSISTOR UN2216-TX	
D434	6-500-522-21	DIODE 10EDB40-TB3		Q310	8-729-922-37	TRANSISTOR 2SD2144S-TP-UVW	
D451	6-500-522-21	DIODE 10EDB40-TB3		Q380	8-729-015-74	TRANSISTOR UN5111-TX	
D452	6-500-522-21	DIODE 10EDB40-TB3				< RESISTOR >	
D453	6-500-522-21	DIODE 10EDB40-TB3		R4	1-216-809-11	METAL CHIP 100 5% 1/10W	
D454	6-500-522-21	DIODE 10EDB40-TB3		R5	1-216-833-11	METAL CHIP 10K 5% 1/10W	
D461	6-500-522-21	DIODE 10EDB40-TB3		R9	1-216-829-11	METAL CHIP 4.7K 5% 1/10W	
D462	8-719-422-64	DIODE MA8062-M-TX		R10	1-216-833-11	METAL CHIP 10K 5% 1/10W	
D471	8-719-988-61	DIODE 1SS355TE-17		R17	1-216-845-11	METAL CHIP 100K 5% 1/10W	
D472	8-719-988-61	DIODE 1SS355TE-17		R18	1-216-833-11	METAL CHIP 10K 5% 1/10W	
D473	8-719-988-61	DIODE 1SS355TE-17		R20	1-216-833-11	METAL CHIP 10K 5% 1/10W	
		< IC >		R24	1-216-826-11	METAL CHIP 2.7K 5% 1/10W	
IC1	6-803-241-01	IC M30624MWP-068FP		R26	1-216-847-11	METAL CHIP 150K 5% 1/10W	
IC100	8-759-643-31	IC BR24C02FV-WE2		R28	1-216-843-11	METAL CHIP 68K 5% 1/10W	
IC310	8-759-278-58	IC NJM4558V-TE2		R29	1-216-833-11	METAL CHIP 10K 5% 1/10W	
IC370	8-759-278-58	IC NJM4558V-TE2		R30	1-216-833-11	METAL CHIP 10K 5% 1/10W	
IC390	8-759-697-21	IC NJM4565V(Te2)		R32	1-216-833-11	METAL CHIP 10K 5% 1/10W	
IC410	8-759-039-69	IC uPC7805AHF		R34	1-216-833-11	METAL CHIP 10K 5% 1/10W	
IC420	8-759-039-69	IC uPC7805AHF		R41	1-216-864-11	METAL CHIP 0 5% 1/10W	
IC426	8-759-445-59	IC BA033T		R42	1-216-833-11	METAL CHIP 10K 5% 1/10W	
IC430	8-759-231-55	IC TA7808S		R43	1-216-833-11	METAL CHIP 10K 5% 1/10W	
IC440	8-759-071-48	IC TA7807S		R46	1-216-864-11	METAL CHIP 0 5% 1/10W	
IC450	8-759-231-55	IC TA7808S		R48	1-216-833-11	METAL CHIP 10K 5% 1/10W	
IC460	8-759-633-42	IC M5293L		R50	1-216-833-11	METAL CHIP 10K 5% 1/10W	
IC476	8-759-387-77	IC TC7WU04F-TE12L		R59	1-216-833-11	METAL CHIP 10K 5% 1/10W	
IC480	6-702-913-01	IC S-80929CNMC-G8ZT2G		R60	1-216-833-11	METAL CHIP 10K 5% 1/10W	
IC500	6-701-843-01	IC AK4584VQ		R67	1-216-833-11	METAL CHIP 10K 5% 1/10W	
IC610	6-600-013-01	IC TORX179L (OPTICAL IN)		R76	1-216-845-11	METAL CHIP 100K 5% 1/10W	
IC620	6-600-011-01	IC TOTX179L (OPTICAL OUT)		R77	1-216-833-11	METAL CHIP 10K 5% 1/10W	
IC650	8-759-548-95	IC SN74LV00APWR		R78	1-216-833-11	METAL CHIP 10K 5% 1/10W	
		< JACK >		R80	1-216-833-11	METAL CHIP 10K 5% 1/10W	
J310	1-784-429-11	JACK, PIN 4P (ANALOG IN,OUT)		R81	1-216-845-11	METAL CHIP 100K 5% 1/10W	
		< COIL >		R85	1-216-833-11	METAL CHIP 10K 5% 1/10W	
L390	1-216-295-91	SHORT CHIP 0		R89	1-216-835-11	METAL CHIP 15K 5% 1/10W	
L391	1-216-295-91	SHORT CHIP 0		R91	1-216-809-11	METAL CHIP 100 5% 1/10W	
L517	1-216-295-91	SHORT CHIP 0		R107	1-216-833-11	METAL CHIP 10K 5% 1/10W	
L535	1-216-864-11	METAL CHIP 0 5% 1/10W		R111	1-216-839-11	METAL CHIP 33K 5% 1/10W	
L539	1-216-295-91	SHORT CHIP 0		R112	1-216-837-11	METAL CHIP 22K 5% 1/10W	
L600	1-414-267-21	INDUCTOR 10uH		R113	1-216-849-11	METAL CHIP 220K 5% 1/10W	
L632	1-414-760-21	FERRITE 0uH		R115	1-216-805-11	METAL CHIP 47 5% 1/10W	
L636	1-414-760-21	FERRITE 0uH					
L650	1-216-295-91	SHORT CHIP 0					
L652	1-414-760-21	FERRITE 0uH					
L656	1-414-760-21	FERRITE 0uH					

The components identified by mark △ or dotted line with mark △ are critical for safety. Replace only with part number specified.	Les composants identifiés par une marque △ sont critiques pour la sécurité. Ne les remplacer que par une pièce portant le numéro spécifié.
--	--

RCD-W500C

MAIN	OUT SW	POWER
-------------	---------------	--------------

Ref. No.	Part No.	Description	Quantity	Power	Remarks
R170	1-216-845-11	METAL CHIP	100K	5%	1/10W
R171	1-216-864-11	METAL CHIP	0	5%	1/10W
R172	1-216-864-11	METAL CHIP	0	5%	1/10W
R173	1-216-833-11	METAL CHIP	10K	5%	1/10W
R174	1-216-833-11	METAL CHIP	10K	5%	1/10W
R175	1-216-845-11	METAL CHIP	100K	5%	1/10W
R176	1-216-817-11	METAL CHIP	470	5%	1/10W
R177	1-216-817-11	METAL CHIP	470	5%	1/10W
R181	1-216-833-11	METAL CHIP	10K	5%	1/10W
R191	1-216-805-11	METAL CHIP	47	5%	1/10W
R192	1-216-805-11	METAL CHIP	47	5%	1/10W
R193	1-216-864-11	METAL CHIP	0	5%	1/10W
R211	1-216-839-11	METAL CHIP	33K	5%	1/10W
R212	1-216-837-11	METAL CHIP	22K	5%	1/10W
R213	1-216-849-11	METAL CHIP	220K	5%	1/10W
R215	1-216-805-11	METAL CHIP	47	5%	1/10W
R270	1-216-845-11	METAL CHIP	100K	5%	1/10W
R271	1-216-864-11	METAL CHIP	0	5%	1/10W
R272	1-216-864-11	METAL CHIP	0	5%	1/10W
R273	1-216-833-11	METAL CHIP	10K	5%	1/10W
R274	1-216-833-11	METAL CHIP	10K	5%	1/10W
R275	1-216-845-11	METAL CHIP	100K	5%	1/10W
R276	1-216-817-11	METAL CHIP	470	5%	1/10W
R277	1-216-817-11	METAL CHIP	470	5%	1/10W
R281	1-216-833-11	METAL CHIP	10K	5%	1/10W
R291	1-216-805-11	METAL CHIP	47	5%	1/10W
R292	1-216-805-11	METAL CHIP	47	5%	1/10W
R293	1-216-864-11	METAL CHIP	0	5%	1/10W
R310	1-216-825-11	METAL CHIP	2.2K	5%	1/10W
R311	1-216-841-11	METAL CHIP	47K	5%	1/10W
R380	1-216-845-11	METAL CHIP	100K	5%	1/10W
R381	1-216-847-11	METAL CHIP	150K	5%	1/10W
△R401	1-219-786-11	FUSIBLE	22	5%	1/4W
△R403	1-219-786-11	FUSIBLE	22	5%	1/4W
R406	1-216-821-11	METAL CHIP	1K	5%	1/10W
R441	1-216-864-11	METAL CHIP	0	5%	1/10W
R461	1-216-837-11	METAL CHIP	22K	5%	1/10W
R462	1-216-845-11	METAL CHIP	100K	5%	1/10W
R463	1-216-813-11	METAL CHIP	220	5%	1/10W
R464	1-216-813-11	METAL CHIP	220	5%	1/10W
R470	1-216-809-11	METAL CHIP	100	5%	1/10W
R471	1-216-864-11	METAL CHIP	0	5%	1/10W
R472	1-216-822-11	METAL CHIP	1.2K	5%	1/10W
R473	1-216-815-11	METAL CHIP	330	5%	1/10W
R474	1-216-833-11	METAL CHIP	10K	5%	1/10W
R475	1-216-843-11	METAL CHIP	68K	5%	1/10W
R476	1-216-853-11	METAL CHIP	470K	5%	1/10W
R477	1-216-821-11	METAL CHIP	1K	5%	1/10W
R480	1-216-841-11	METAL CHIP	47K	5%	1/10W
R504	1-216-864-11	METAL CHIP	0	5%	1/10W
R506	1-216-809-11	METAL CHIP	100	5%	1/10W
R507	1-216-809-11	METAL CHIP	100	5%	1/10W
R513	1-216-864-11	METAL CHIP	0	5%	1/10W
R514	1-216-864-11	METAL CHIP	0	5%	1/10W
R516	1-216-864-11	METAL CHIP	0	5%	1/10W
R539	1-216-793-11	METAL CHIP	4.7	5%	1/10W
R540	1-216-834-11	METAL CHIP	12K	5%	1/10W
R611	1-216-817-11	METAL CHIP	470	5%	1/10W

Ref. No.	Part No.	Description	Quantity	Power	Remarks
R632	1-216-813-11	METAL CHIP	220	5%	1/10W
R636	1-216-813-11	METAL CHIP	220	5%	1/10W
R651	1-216-845-11	METAL CHIP	100K	5%	1/10W
R652	1-216-809-11	METAL CHIP	100	5%	1/10W
R653	1-216-845-11	METAL CHIP	100K	5%	1/10W
R656	1-216-813-11	METAL CHIP	220	5%	1/10W
R658	1-216-845-11	METAL CHIP	100K	5%	1/10W
R659	1-216-809-11	METAL CHIP	100	5%	1/10W
R1090	1-216-864-11	METAL CHIP	0	5%	1/10W
R1092	1-216-864-11	METAL CHIP	0	5%	1/10W
< COMPOSITION CIRCUIT BLOCK >					
RB51	1-236-908-11	RES, CHIP NETWORK 10K (3216)			
RB55	1-236-908-11	RES, CHIP NETWORK 10K (3216)			
RB72	1-236-908-11	RES, CHIP NETWORK 10K (3216)			
RB82	1-236-908-11	RES, CHIP NETWORK 10K (3216)			
RB86	1-236-908-11	RES, CHIP NETWORK 10K (3216)			
RB93	1-233-418-11	RES, CHIP NETWORK 3.3K (3216)			
RB509	1-233-576-11	RES, CHIP NETWORK 100			
< RELAY >					
RY310	1-755-359-11	RELAY			
< VIBRATOR >					
X15	1-795-058-21	VIBRATOR, CERAMIC (5MHz)			

1-675-725-11 OUT SW BOARD					

< CONNECTOR >					
* CN709	1-568-943-11	PIN, CONNECTOR 5P			
< SWITCH >					
S701	1-771-218-11	SWITCH, MICRO (MID OUT)			
S702	1-771-218-11	SWITCH, MICRO (LID)			
S708	1-771-218-11	SWITCH, MICRO (OUT)			

1-683-869-21 POWER BOARD					

< CAPACITOR >					
△C921	1-113-920-11	CERAMIC	0.0022uF	20.00%	250V
< CONNECTOR >					
* CN920	1-580-230-31	PIN, CONNECTOR (PC BOARD) 2P			
< SWITCH >					
△S921	1-572-267-51	SWITCH, PUSH (AC POWER)(1 KEY)(POWER)			

The components identified by mark △ or dotted line with mark △ are critical for safety. Replace only with part number specified.	Les composants identifiés par une marque △ sont critiques pour la sécurité. Ne les remplacer que par une pièce portant le numéro spécifié.
--	--

SENSOR

SENSOR 2

SW

Ref. No.	Part No.	Description	Remarks	Ref. No.	Part No.	Description	Remarks
	1-675-726-11	SENSOR BOARD *****				MISCELLANEOUS *****	
	4-964-461-02	HOLDER (SENSOR) < CONNECTOR >		△ 5	1-783-531-42	CORD, POWER	
				65	1-823-923-11	WIRE (FLAT TYPE) (21 CORE)	
				107	1-823-925-11	WIRE(FLAT TYPE) (17CORE)	
				109	1-782-881-11	WIRE(FLAT TYPE) (25CORE)	
				110	1-823-922-11	WIRE(FLAT TYPE) (11CORE)	
CN708	1-506-481-11	PIN, CONNECTOR 2P < DIODE >		111	1-782-864-11	WIRE (FLAT TYPE) (9 CORE)	
				552	1-782-817-11	WIRE (FLAT TYPE) (16 CORE)	
D704	8-719-055-84	DIODE GL528VS1 (DISC IN DET SENSOR) < RESISTOR >		△ 553	A-4735-885-A	BU-30B ASSY	
				601	1-823-651-11	CABLE, FLEXIBLE FLAT (32 CORE)	
				△ 603	8-583-104-01	OPTICAL PICK-UP (KRM-220CAA)	
R711	1-249-415-11	CARBON 680 5% 1/4W F *****		* 609	1-452-958-11	MAGNET (CHUCKING)	
				M201	A-4735-557-A	MOTOR ASSY (LOADING)	
				M701	1-541-632-12	MOTOR, DC (ELEVATOR)	
				M702	1-541-632-12	MOTOR, DC (LOADING)	
				S707	1-418-045-01	ENCODER, ROTARY	
	1-675-727-11	SENSOR 2 BOARD ***** < TRANSISTOR >		△ T900	1-439-732-11	TRANSFORMER, POWER *****	
						ACCESSORIES *****	
Q703	8-729-921-53	PHOTO TRANSISTOR PT483F1 (DISC IN DET SENSOR) *****		1-477-901-11	COMMANDER, STANDARD (RM-R52)		
				1-776-263-12	CORD, CONNECTION		
				1-790-735-12	CORD, CONNECTION		
				4-228-696-01	BATTERY,COVER (FOR RM-R52)		
				4-246-076-11	MANUAL, INSTRUCTION (ENGLISH)		
	1-683-867-21	SW BOARD ***** < RESISTOR >		4-246-076-21	MANUAL, INSTRUCTION (FRENCH) (CND)		
R725	1-249-417-11	CARBON 1K 5% 1/4W F					
R726	1-249-419-11	CARBON 1.5K 5% 1/4W F					
R727	1-249-421-11	CARBON 2.2K 5% 1/4W F					
R728	1-249-425-11	CARBON 4.7K 5% 1/4W F					
R729	1-249-429-11	CARBON 10K 5% 1/4W F					
S725	1-762-875-21	SWITCH, KEYBOARD (PLAY MODE (CD))					
S726	1-762-875-21	SWITCH, KEYBOARD (TIME (CD))					
S727	1-762-875-21	SWITCH, KEYBOARD (▷ (CD))					
S728	1-762-875-21	SWITCH, KEYBOARD (■ (CD))					
S729	1-762-875-21	SWITCH, KEYBOARD (■ (CD)) *****					

The components identified by mark △ or dotted line with mark △ are critical for safety. Replace only with part number specified.	Les composants identifiés par une marque △ sont critiques pour la sécurité. Ne les remplacer que par une pièce portant le numéro spécifié.
--	--

